

Isolated Fixed-Ratio DC-DC Converter

Features & Benefits

- Up to 150A continuous low voltage side current
- Fixed transformation ratio (K) of 1/6
- Up to 769W/in³ power density
- 97.2% peak efficiency
- Integrated ceramic capacitance filtering
- Parallel operation for multi-kW arrays
- OV, OC, UV, short circuit and thermal protection
- 3814 package
- High MTBF
- Thermally enhanced VIA package
- PMBus[™] management interface

Typical Applications

- DC Power Distribution
- Information and Communication Technology (ICT) Equipment
- High End Computing Systems
- Automated Test Equipment
- Industrial Systems
- High Density Energy Systems
- Transportation

Part Ordering Information

| Product Function | Package Length | Package Width | Package Type | Max High Side Voltage | High Side Voltage Range Ratio | Max Low Side Voltage | Max Low Side Current | Product Grade (Case Temperature) | Option Field |
|----------------------------|-----------------------|----------------------|----------------------------------|-----------------------|-------------------------------|----------------------|----------------------|--|---|
| BCM | 38 | 14 | x | 60 | E | 10 | A5 | y | zz |
| BCM = Bus Converter Module | Length in Inches x 10 | Width in Inches x 10 | B = Board VIA V = Chassis VIA | Internal Reference | | | | C = -20 to 100°C ^[1] T = -40 to 100°C ^[1] | 02 = Chassis/PMBus 06 = Short Pin/PMBus 10 = Long Pin/PMBus |

^[1] The PMBus name, SMIF, Inc. and logo are trademarks of SMIF, Inc.

^[2] High temperature current derating may apply; See Figure 1, specified thermal operating area.

| Product Ratings | |
|--------------------------------------|-------------------------------|
| $V_{HI} = 54V (36 - 60V)$ | $I_{LO} = \text{up to } 150A$ |
| $V_{LO} = 9V (6 - 10V)$ (NO LOAD) | $K = 1/6$ |

Product Description

The BCM3814x60E10A5yzz in a VIA package is a high efficiency Bus Converter, operating from a 36 to 60V_{DC} high voltage bus to deliver an isolated 6 to 10V_{DC} unregulated, low voltage.

This unique ultra-low profile module incorporates DC-DC conversion, integrated filtering and PMBus[™] commands and controls in a chassis or PCB mount form factor.

The BCM offers low noise, fast transient response and industry leading efficiency and power density. A low voltage side referenced PMBus[™] compatible telemetry and control interface provides access to the BCM's configuration, fault monitoring and other telemetry functions.

Leveraging the thermal and density benefits of Vicor's VIA packaging technology, the BCM module offers flexible thermal management options with very low top and bottom side thermal impedances.

When combined with downstream Vicor DC-DC conversion components and regulators, the BCM allows the Power Design Engineer to employ a simple, low-profile design, which will differentiate the end system without compromising on cost or performance metrics.



Size:
3.76 x 1.40 x 0.37in
95.59 x 35.54 x 9.40mm

Typical Applications

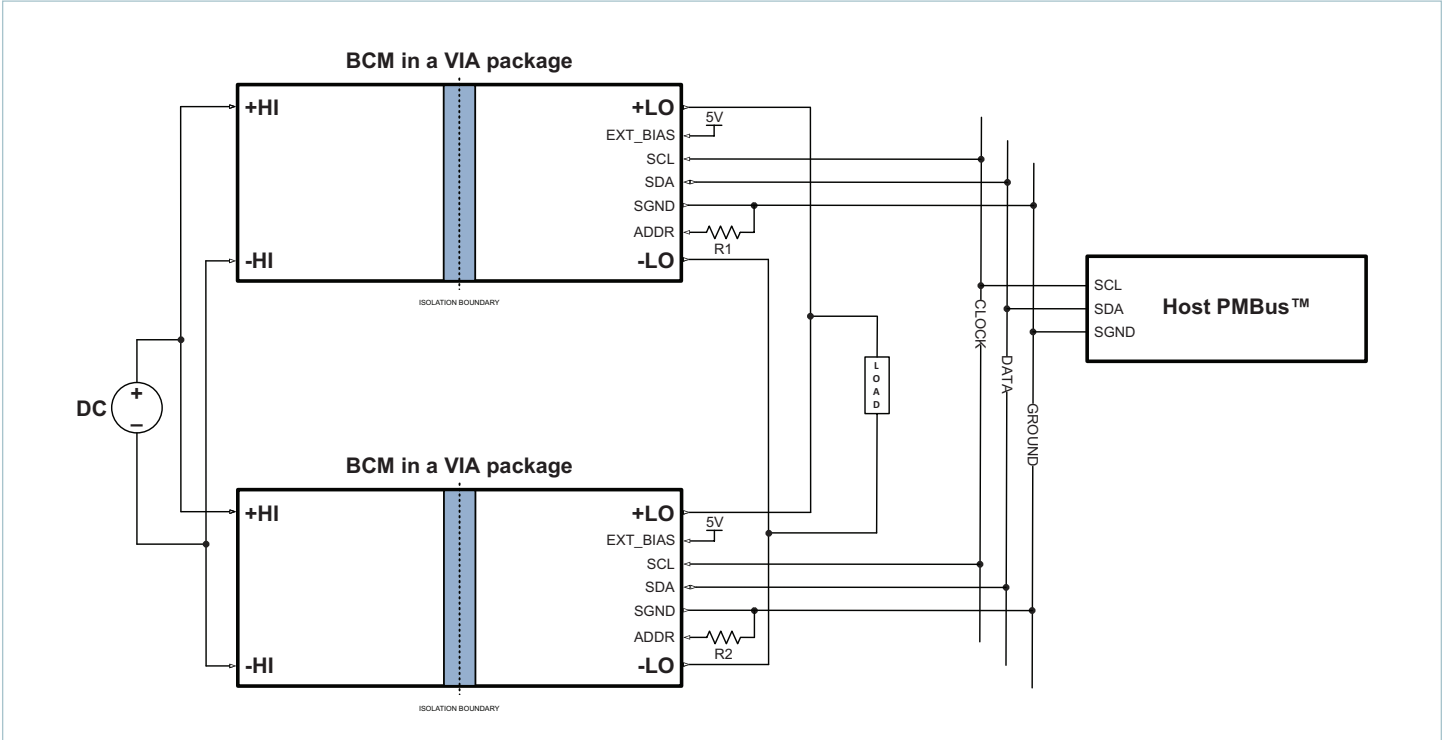

Paralleling PMBus BCM in a VIA package – connection to Host PMBus

Typical Applications (Cont.)

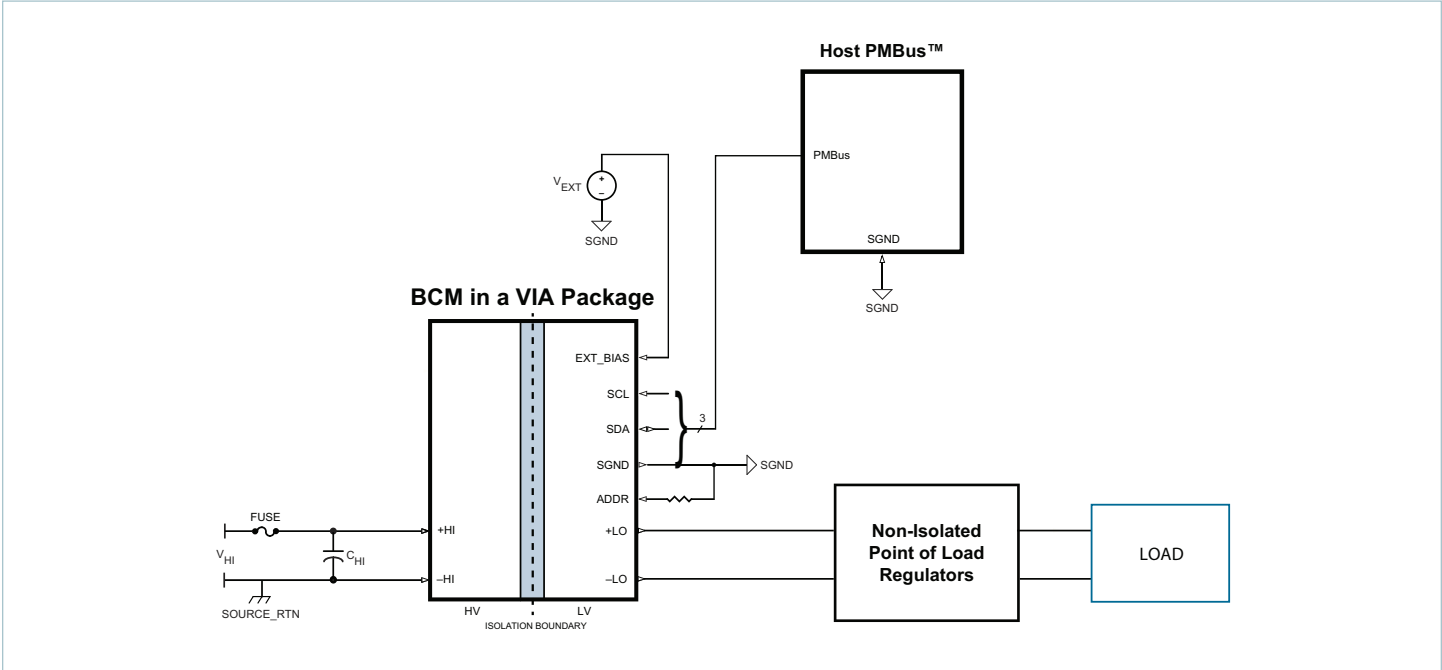

BCM3814x60E10A5yzz at point of load – connection to Host PMBus – connection to Host PMBus

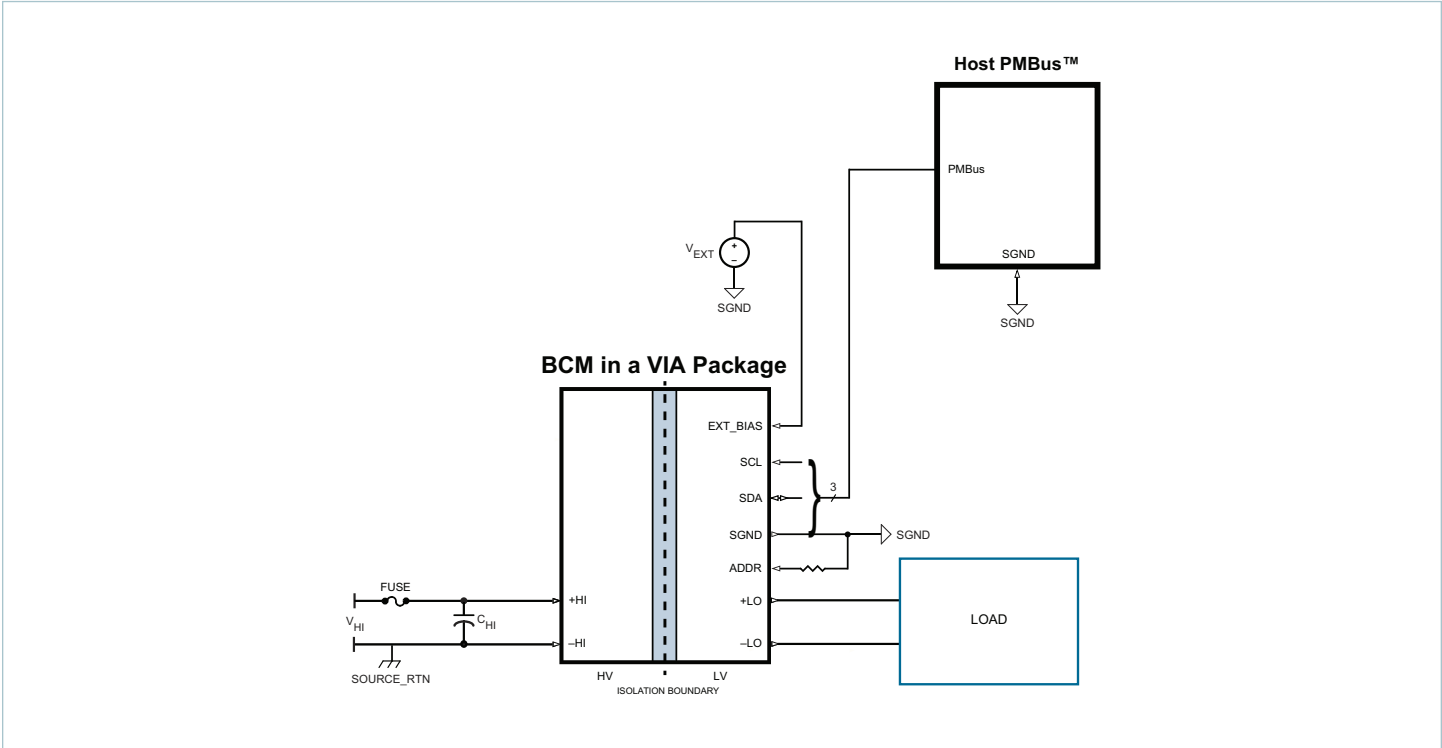

BCM3814x60E10A5yzz direct to load – connection to Host PMBus

Pin Configuration

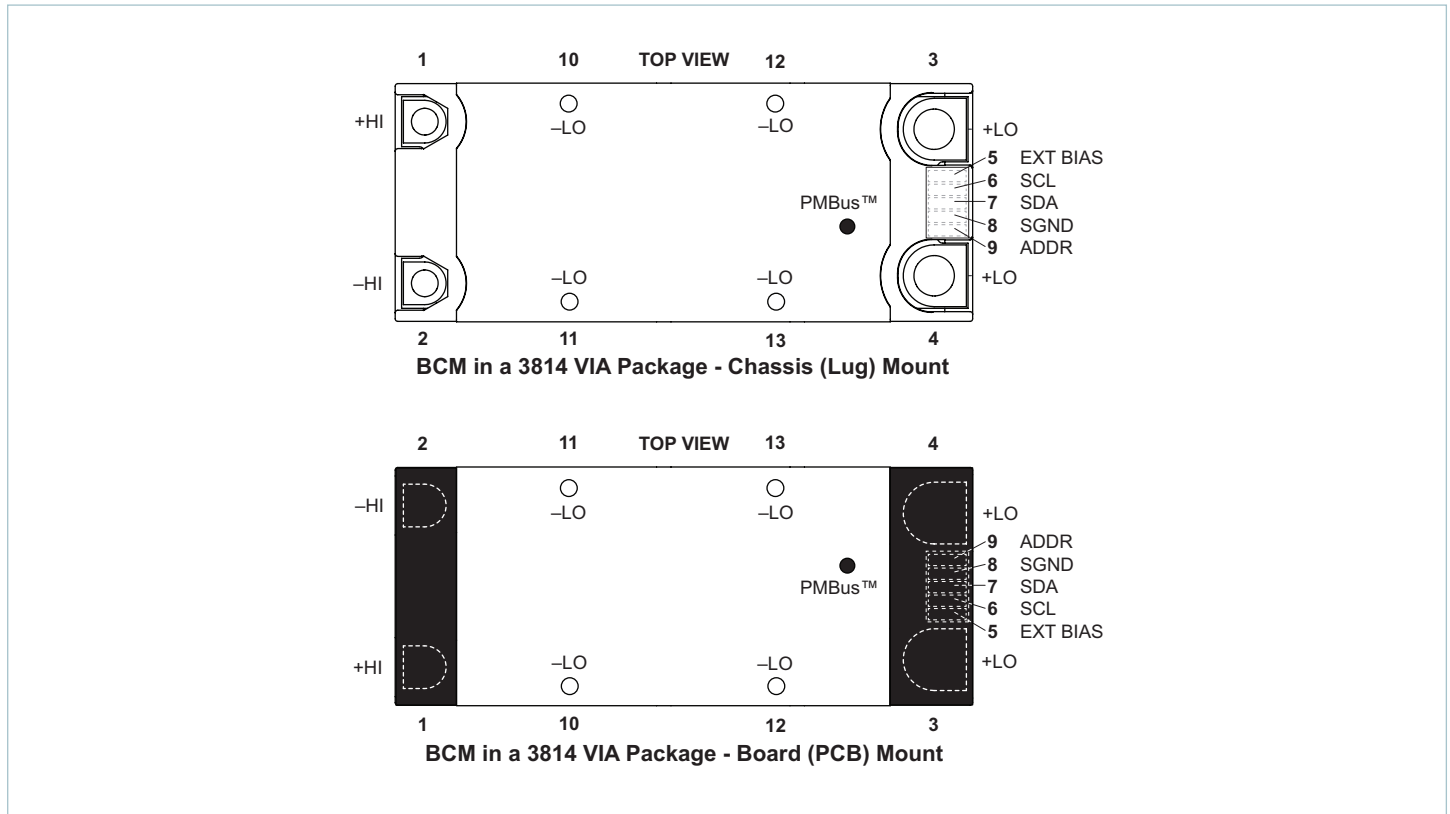

Note: The dot on the VIA housing indicates the location of the signal pin 9.

Pin Descriptions

| Pin Number | Signal Name | Type | Function |
|----------------|-------------|------------------------|--|
| 1 | +HI | HIGH SIDE POWER | High voltage side positive power terminal |
| 2 | -HI | HIGH SIDE POWER RETURN | High voltage side negative power terminal |
| 3, 4 | +LO | LOW SIDE POWER | Low voltage side positive power terminal |
| 5 | EXT BIAS | INPUT | 5V supply input |
| 6 | SCL | INPUT | I ² C™ [1] Clock, PMBus™ Compatible |
| 7 | SDA | INPUT/OUTPUT | I ² C Data, PMBus Compatible |
| 8 | SGND | LOW SIDE SIGNAL RETURN | Signal Ground |
| 9 | ADDR | INPUT | Address assignment - Resistor based |
| 10, 11, 12, 13 | -LO | LOW SIDE POWER RETURN | Low voltage side negative power terminal |

Notes: All signal pins (5, 6, 7, 8, 9) are referenced to the low voltage side and isolated from the high voltage side. Keep SGND signal separated from the low voltage side power return terminal (-LO) in electrical design.

[1] I²C™ is a trademark of NXP Semiconductor

Absolute Maximum Ratings

The absolute maximum ratings below are stress ratings only. Operation at or beyond these maximum ratings can cause permanent damage to the device.

| Parameter | Comments | Min | Max | Unit |
|--|---|------|------|-----------------|
| +HI to -HI | | -1 | 80 | V |
| HI_DC or LO_DC Slew Rate | | | 1 | V/ μ s |
| +LO to -LO | | -1 | 15 | V |
| EXT BIAS to SGND | | -0.3 | 10 | V |
| | | | 0.15 | A |
| SCL to SGND | | -0.3 | 5.5 | V |
| SDA to SGND | | -0.3 | 5.5 | V |
| ADDR to SGND | | -0.3 | 3.6 | V |
| Isolation Voltage / Dielectric Withstand | Basic insulation (high voltage side to case) | 1500 | | V _{DC} |
| | Basic insulation (high voltage side to low voltage side) ^[1] | 1500 | | V _{DC} |
| | Functional insulation (low voltage side to case) | N/A | | V _{DC} |

^[1] The absolute maximum rating listed above for the dielectric withstand (high voltage side to the low voltage side) refers to the VIA package. The internal safety approved isolating component (ChiP) provides basic insulation (2250V) from the high voltage side to the low voltage side. However, the VIA package itself can only be tested at a basic insulation value (1500V).

Electrical Specifications

Specifications apply over all line and load conditions, unless otherwise noted; **boldface** specifications apply over the temperature range of $-40^{\circ}\text{C} \leq T_{\text{CASE}} \leq 100^{\circ}\text{C}$ (T-Grade); all other specifications are at $T_{\text{CASE}} = 25^{\circ}\text{C}$ unless otherwise noted.

| Attribute | Symbol | Conditions / Notes | Min | Typ | Max | Unit |
|---|-----------------------------|---|-------------|------|-------------|------------|
| General Powertrain Specification – Forward Direction Operation (High Voltage Side to Low Voltage Side) | | | | | | |
| HI Side Voltage Range (Continuous) | $V_{\text{HI_DC}}$ | | 36 | | 60 | V |
| HI Side Voltage Initialization Threshold | $V_{\mu\text{C_ACTIVE}}$ | HI side voltage where internal controller is initialized, (powertrain inactive) | | | 14 | V |
| HI Side Quiescent Current | $I_{\text{HI_Q}}$ | Disabled, $V_{\text{HI_DC}} = 54\text{V}$ | | 5 | | mA |
| | | $T_{\text{CASE}} \leq 100^{\circ}\text{C}$ | | | 10 | |
| No Load Power Dissipation | $P_{\text{HI_NL}}$ | $V_{\text{HI_DC}} = 54\text{V}$, $T_{\text{CASE}} = 25^{\circ}\text{C}$ | | 7.2 | 9 | W |
| | | $V_{\text{HI_DC}} = 54\text{V}$ | 5 | | 14 | |
| | | $V_{\text{HI_DC}} = 36\text{V to } 60\text{V}$, $T_{\text{CASE}} = 25^{\circ}\text{C}$ | | | 12 | |
| | | $V_{\text{HI_DC}} = 36\text{V to } 60\text{V}$ | | | 17 | |
| HI Side Inrush Current Peak | $I_{\text{HI_INR_PK}}$ | $V_{\text{HI_DC}} = 60\text{V}$, $C_{\text{LO_EXT}} = 4000\mu\text{F}$, $R_{\text{LOAD_LO}} = 20\%$ of full load current | | 30 | | A |
| | | $T_{\text{CASE}} \leq 100^{\circ}\text{C}$ | | | 35 | |
| DC HI Side Current | $I_{\text{HI_IN_DC}}$ | At $I_{\text{LO_OUT_DC}} = 150\text{A}$, $T_{\text{CASE}} \leq 85^{\circ}\text{C}$ | | | 25.5 | A |
| Transformation Ratio | K | High voltage to low voltage, $K = V_{\text{LO_DC}} / V_{\text{HI_DC}}$, at no load | | 1/6 | | V/V |
| LO Side Current (Continuous) | $I_{\text{LO_OUT_DC}}$ | $T_{\text{CASE}} \leq 85^{\circ}\text{C}$ | | | 150 | A |
| LO Side Current (Pulsed) | $I_{\text{LO_OUT_PULSE}}$ | 10ms pulse, 25% duty cycle, $I_{\text{LO_OUT_AVG}} \leq 50\%$ rated $I_{\text{LO_OUT_DC}}$ | | | 180 | A |
| Efficiency (Ambient) | η_{AMB} | $V_{\text{HI_DC}} = 54\text{V}$, $I_{\text{LO_OUT_DC}} = 150\text{A}$ | 95.2 | 95.8 | | % |
| | | $V_{\text{HI_DC}} = 36\text{V to } 60\text{V}$, $I_{\text{LO_OUT_DC}} = 150\text{A}$ | 93.6 | | | |
| | | $V_{\text{HI_DC}} = 54\text{V}$, $I_{\text{LO_OUT_DC}} = 75\text{A}$ | 96.7 | 97.2 | | |
| Efficiency (Hot) | η_{HOT} | $V_{\text{HI_DC}} = 54\text{V}$, $I_{\text{LO_OUT_DC}} = 150\text{A}$, $T_{\text{CASE}} = 85^{\circ}\text{C}$ | 95.4 | 95.6 | | % |
| Efficiency (Over Load Range) | $\eta_{20\%}$ | $30\text{A} < I_{\text{LO_OUT_DC}} < 150\text{A}$ | 93 | | | % |
| LO Side Output Resistance | $R_{\text{LO_COLD}}$ | $V_{\text{HI_DC}} = 54\text{V}$, $I_{\text{LO_OUT_DC}} = 150\text{A}$, $T_{\text{CASE}} = -40^{\circ}\text{C}$ | 0.9 | 1.7 | 2.1 | m Ω |
| | $R_{\text{LO_AMB}}$ | $V_{\text{HI_DC}} = 54\text{V}$, $I_{\text{LO_OUT_DC}} = 150\text{A}$ | 2 | 2.1 | 2.4 | |
| | $R_{\text{LO_HOT}}$ | $V_{\text{HI_DC}} = 54\text{V}$, $I_{\text{LO_OUT_DC}} = 150\text{A}$, $T_{\text{CASE}} = 85^{\circ}\text{C}$ | 1.6 | 2.3 | 2.6 | |
| Switching Frequency | F_{SW} | Low side voltage ripple frequency = $2 \times F_{\text{SW}}$ | 0.85 | 0.90 | 0.95 | MHz |
| LO Side Voltage Ripple | $V_{\text{LO_OUT_PP}}$ | $C_{\text{LO_EXT}} = 0\mu\text{F}$, $I_{\text{LO_OUT_DC}} = 150\text{A}$, $V_{\text{HI_DC}} = 54\text{V}$, 20MHz BW | | 120 | | mV |
| | | $T_{\text{CASE}} \leq 100^{\circ}\text{C}$ | | | 200 | |

Electrical Specifications (Cont.)

Specifications apply over all line and load conditions, unless otherwise noted; **boldface** specifications apply over the temperature range of $-40^{\circ}\text{C} \leq T_{\text{CASE}} \leq 100^{\circ}\text{C}$ (T-Grade); all other specifications are at $T_{\text{CASE}} = 25^{\circ}\text{C}$ unless otherwise noted.

| Attribute | Symbol | Conditions / Notes | Min | Typ | Max | Unit |
|--|-----------------------------|--|------------|------|-------------|--------------------|
| General Powertrain Specification – Forward Direction Operation (High Voltage Side to Low Voltage Side), Cont. | | | | | | |
| Effective HI Side Capacitance (Internal) | $C_{\text{HI_INT}}$ | Effective value at $54V_{\text{HI_DC}}$ | | 11.2 | | μF |
| Effective LO Side Capacitance (Internal) | $C_{\text{LO_INT}}$ | Effective value at $9V_{\text{LO_DC}}$ | | 202 | | μF |
| Rated LO Side Capacitance (External) | $C_{\text{LO_OUT_EXT}}$ | Excessive capacitance may drive module into short circuit protection | | | 6000 | μF |
| Rated LO Side Capacitance (External), Parallel Array Operation | $C_{\text{LO_OUT_AEXT}}$ | $C_{\text{LO_OUT_AEXT Max}} = N * 0.5 * C_{\text{LO_OUT_EXT Max}}$, where N = the number of units in parallel | | | | |
| Powertrain Hardware Protection Specification – Forward Direction Operation (High Voltage Side to Low Voltage Side) | | | | | | |
| <ul style="list-style-type: none"> • These built-in powertrain protections are fixed in hardware and cannot be configured through PMBus™. • When duplicated in supervisory limits, hardware protections serve a secondary role and become active when supervisory limits are disabled through PMBus. | | | | | | |
| Auto Restart Time | $t_{\text{AUTO_RESTART}}$ | Startup into a persistent fault condition. Non-latching fault detection given $V_{\text{HI_DC}} > V_{\text{HI_UVLO+}}$ | 490 | | 560 | ms |
| HI Side Overvoltage Lockout Threshold | $V_{\text{HI_OVLO+}}$ | | 63 | 67 | 71 | V |
| HI Side Overvoltage Recovery Threshold | $V_{\text{HI_OVLO-}}$ | | 61 | 65 | 69 | V |
| HI Side Overvoltage Lockout Hysteresis | $V_{\text{HI_OVLO_HYST}}$ | | | 2 | | V |
| HI Side Overvoltage Lockout Response Time | $t_{\text{HI_OVLO}}$ | | | 100 | | μs |
| HI Side Soft-Start Time | $t_{\text{HI_SOFT-START}}$ | From powertrain active. Fast current limit protection disabled during soft-start | | 1 | | ms |
| LO Side Overcurrent Trip Threshold | $I_{\text{LO_OUT_OCP}}$ | | 180 | 204 | 240 | A |
| LO Side Overcurrent Response Time Constant | $t_{\text{LO_OUT_OCP}}$ | Effective internal RC filter | | 3 | | ms |
| LO Side Short Circuit Protection Trip Threshold | $I_{\text{LO_OUT_SCP}}$ | | 195 | | | A |
| LO Side Short Circuit Protection Response Time | $t_{\text{LO_OUT_SCP}}$ | | | 1 | | μs |
| Overtemperature Shutdown Threshold | $t_{\text{OTP+}}$ | Internal | 125 | | | $^{\circ}\text{C}$ |

Electrical Specifications (Cont.)

Specifications apply over all line and load conditions, unless otherwise noted; **boldface** specifications apply over the temperature range of $-40^{\circ}\text{C} \leq T_{\text{CASE}} \leq 100^{\circ}\text{C}$ (T-Grade); all other specifications are at $T_{\text{CASE}} = 25^{\circ}\text{C}$ unless otherwise noted.

| Attribute | Symbol | Conditions / Notes | Min | Typ | Max | Unit |
|--|-------------------------------|---|------------|-----|------------|--------------------|
| Powertrain Supervisory Limits Specification – Forward Direction Operation (High Voltage Side to Low Voltage Side) | | | | | | |
| <ul style="list-style-type: none"> • These supervisory limits are set in the internal controller and can be reconfigured or disabled through PMBus™. • When disabled, the powertrain protections presented in the previous table will intervene during fault events. | | | | | | |
| HI Side Overvoltage Lockout Threshold | $V_{\text{HI_OVLO+}}$ | | 64 | 66 | 68 | V |
| HI Side Overvoltage Recovery Threshold | $V_{\text{HI_OVLO-}}$ | | 60 | 64 | 66 | V |
| HI Side Overvoltage Lockout Hysteresis | $V_{\text{HI_OVLO_HYST}}$ | | | 2 | | V |
| HI Side Overvoltage Lockout Response Time | $t_{\text{HI_OVLO}}$ | | | 100 | | μs |
| HI Side Undervoltage Lockout Threshold | $V_{\text{HI_UVLO-}}$ | | 26 | 28 | 30 | V |
| HI Side Undervoltage Recovery Threshold | $V_{\text{HI_UVLO+}}$ | | 28 | 30 | 32 | V |
| HI Side Undervoltage Lockout Hysteresis | $V_{\text{HI_UVLO_HYST}}$ | | | 2 | | V |
| HI Side Undervoltage Lockout Response Time | $t_{\text{HI_UVLO}}$ | | | 100 | | μs |
| HI Side Undervoltage Startup Delay | $t_{\text{HI_UVLO+_DELAY}}$ | From $V_{\text{HI_DC}} = V_{\text{HI_UVLO+}}$ to powertrain active (i.e., one time startup delay from application of $V_{\text{HI_DC}}$ to $V_{\text{LO_DC}}$) | | 20 | | ms |
| LO Side Overcurrent Trip Threshold | $I_{\text{LO_OUT_OCP}}$ | | 193 | 204 | 215 | A |
| LO Side Overcurrent Response Time Constant | $t_{\text{LO_OUT_OCP}}$ | Effective internal RC filter | | 3 | | ms |
| Overtemperature Shutdown Threshold | $t_{\text{OTP+}}$ | Internal | 125 | | | $^{\circ}\text{C}$ |
| Overtemperature Recovery Threshold | $t_{\text{OTP-}}$ | Internal | 105 | 110 | 115 | $^{\circ}\text{C}$ |
| Undertemperature Shutdown Threshold (Internal) | t_{UTP} | C-Grade | | | -25 | $^{\circ}\text{C}$ |
| | | T-Grade | | | -45 | |
| Undertemperature Restart Time | $t_{\text{UTP_RESTART}}$ | Startup into a persistent fault condition. Non-latching fault detection given $V_{\text{HI_DC}} > V_{\text{HI_UVLO+}}$ | | 3 | | s |

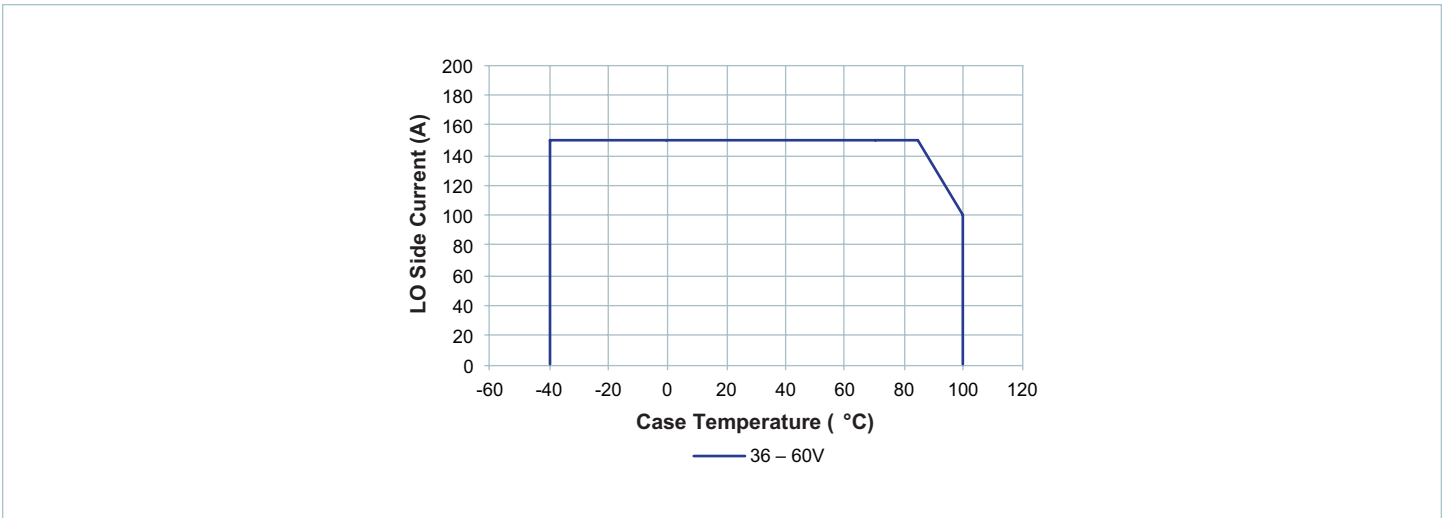

Figure 1 — Specified thermal operating area

1. The BCM in a VIA package is cooled through the bottom case (bottom housing).
2. The thermal rating is based on typical measured device efficiency.
3. The case temperature in the graph is the measured temperature of the bottom housing, such that the internal operating temperature does not exceed 125°C.

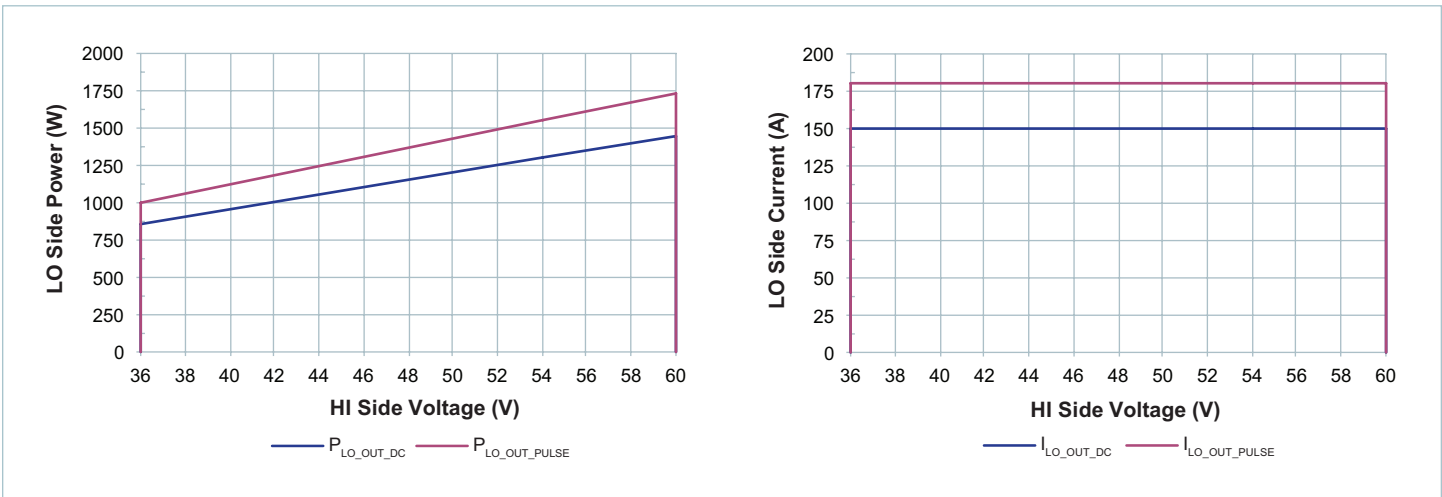

Figure 2 — Specified electrical operating area using rated R_{LO_HOT}

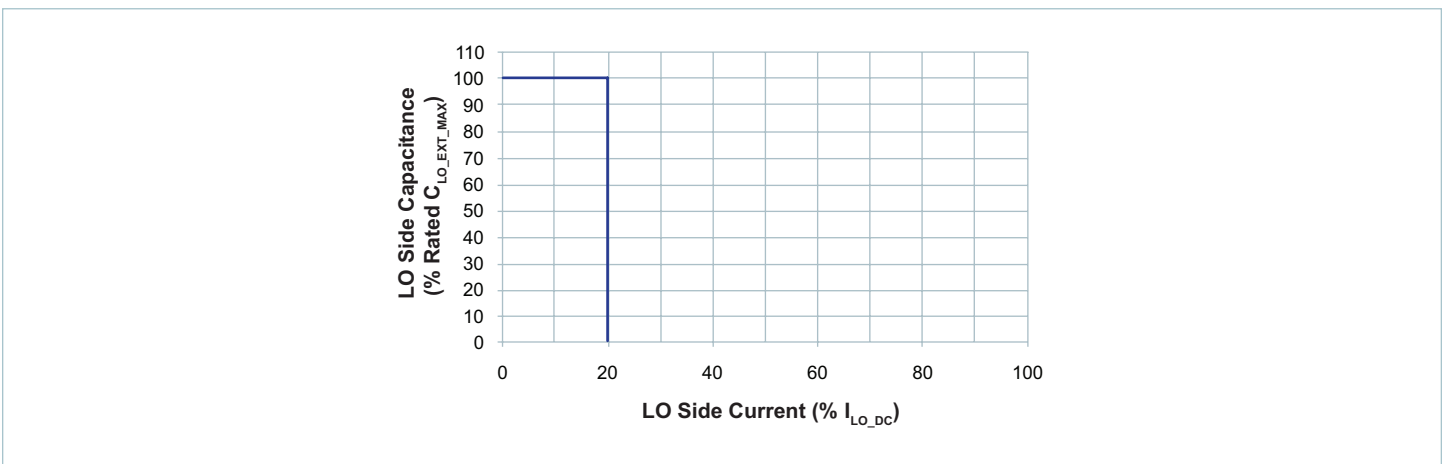

Figure 3 — Specified HI side startup into load current and external capacitance

PMBus™ Reported Characteristics

Specifications apply over all line and load conditions, unless otherwise noted; **boldface** specifications apply over the temperature range of -40°C ≤ T_{CASE} ≤ 100°C (T-Grade); all other specifications are at T_{CASE} = 25°C unless otherwise noted.

| Monitored Telemetry | | | | | |
|--------------------------------|--------------------------|---|----------------------------|-------------|--|
| ATTRIBUTE | PMBus™ READ COMMAND | ACCURACY (RATED RANGE) | FUNCTIONAL REPORTING RANGE | UPDATE RATE | REPORTED UNITS |
| HI Side Voltage | (88h) READ_VIN | ± 5% (LL - HL) | 28V to 66V | 100µs | V _{ACTUAL} = V _{REPORTED} × 10 ⁻¹ |
| HI Side Current | (89h) READ_IIN | ± 20% (10 - 20% of FL) ± 5% (20 - 133% of FL) | -1A to 34A | 100µs | I _{ACTUAL} = I _{REPORTED} × 10 ⁻² |
| LO Side Voltage ^[1] | (88h) READ_VOUT | ± 5% (LL - HL) | 4.7V to 11V | 100µs | V _{ACTUAL} = V _{REPORTED} × 10 ⁻¹ |
| LO Side Current | (8Ch) READ_IOUT | ± 20% (10 - 20% of FL) ± 5% (20 - 133% of FL) | -6A to 204A | 100µs | I _{ACTUAL} = I _{REPORTED} × 10 ⁻² |
| LO Side Resistance | (D4h) READ_ROUT | ± 5% (50 - 100% of FL) at NL ± 10% (50 - 100% of FL) (LL - HL) | 500µΩ to 3000µΩ | 100ms | R _{ACTUAL} = R _{REPORTED} × 10 ⁻⁵ |
| Temperature ^[2] | (8Dh) READ_TEMPERATURE_1 | ± 7°C (Full Range) | - 55°C to 130°C | 100ms | T _{ACTUAL} = T _{REPORTED} |

^[1] Default READ LO Side Voltage returned when unit is disabled = -300V.

^[2] Default READ Temperature returned when unit is disabled = -273°C.

| Variable Parameters | | | | | |
|--|--------------------------|---|--|----------------------------|---------------|
| ATTRIBUTE | PMBus™ COMMAND | CONDITIONS / NOTES | ACCURACY (RATED RANGE) | FUNCTIONAL REPORTING RANGE | DEFAULT VALUE |
| <ul style="list-style-type: none"> • Factory setting of all Thresholds and Warning limits listed below are 100% of specified protection values. • Variables can be written only when module is disabled with V_{HI} < V_{HI_UVLO} and external bias (VDDB) applied. • Module must remain in a disabled mode for 3ms after any changes to the variables below to allow sufficient time to commit changes to EEPROM. | | | | | |
| HI Side Overvoltage Protection Limit | (55h) VIN_OV_FAULT_LIMIT | V _{HI_OVLO} is automatically 3% lower than this setpoint | ± 5% (LL - HL) | 28V to 66V | 100% |
| HI Side Overvoltage Warning Limit | (57h) VIN_OV_WARN_LIMIT | | ± 5% (LL - HL) | 28V to 66V | 100% |
| HI Side Undervoltage Protection Limit | (D7h) DISABLE_FAULTS | Can only be disabled to a preset default value | ± 5% (LL - HL) | 28V or 66V | 100% |
| HI Side Overcurrent Protection Limit | (5Bh) IIN_OC_FAULT_LIMIT | | ± 20% (10 - 20% of FL) ± 5% (20 - 133% of FL) | 0 to 34A | 100% |
| HI Side Overcurrent Warning Limit | (5Dh) IIN_OC_WARN_LIMIT | | ± 20% (10 - 20% of FL) ± 5% (20 - 133% of FL) | 0 to 34A | 100% |
| Overtemperature Protection Limit | (4Fh) OT_FAULT_LIMIT | Internal temperature | ± 7°C (Full Range) | 0 to 125°C | 100% |
| Overtemperature Warning Limit | (51h) OT_WARN_LIMIT | Internal temperature | ± 7°C (Full Range) | 0 to 125°C | 100% |
| Turn On Delay | (60h) TON_DELAY | Additional time delay to the undervoltage startup delay | ± 50µs | 0 to 100ms | 0ms |

Signal Characteristics

Specifications apply over all line and load conditions, unless otherwise noted; **boldface** specifications apply over the temperature range of $-40^{\circ}\text{C} \leq T_{\text{CASE}} \leq 100^{\circ}\text{C}$ (T-Grade); all other specifications are at $T_{\text{CASE}} = 25^{\circ}\text{C}$ unless otherwise noted. **Please note:** For chassis mount model, Vicor part number 42550 will be needed for applications requiring the use of the signal pins. Signal cable 42550 is rated up to five insertions and extractions. To avoid unnecessary stress on the connector, the cable should be appropriately strain relieved.

| EXT. BIAS (VDDB) Pin | | | | | | | | |
|---|-------------------|--------------------------|------------------------|---|-----|-----|-----|------|
| <ul style="list-style-type: none"> VDDB powers the internal controller. VDDB needs to be applied to enable and disable the BCM through PMBus™ control (using OPERATION COMMAND), and to adjust warning and protection thresholds. VDDB voltage not required for telemetry; however, if VDDB is not applied, telemetry information will be lost when V_{IN} is removed. | | | | | | | | |
| SIGNAL TYPE | STATE | ATTRIBUTE | SYMBOL | CONDITIONS / NOTES | MIN | TYP | MAX | UNIT |
| INPUT | Regular Operation | VDDB Voltage | V_{VDDB} | | 4.5 | 5 | 9 | V |
| | | VDDB Current Consumption | I_{VDDB} | | | | 50 | mA |
| | Startup | Inrush Current Peak | $I_{\text{VDDB_INR}}$ | V_{VDDB} slew rate = $1\text{V}/\mu\text{s}$ | | 3.5 | | A |
| | | Turn On Time | $t_{\text{VDDB_ON}}$ | From $V_{\text{VDDB_MIN}}$ to PMBus active | | 1.5 | | ms |

| SGND Pin | | | | | | | | |
|---|--|--|--|--|--|--|--|--|
| <ul style="list-style-type: none"> All PMBus interface signals (SCL, SDA, ADDR) are referenced to SGND pin. SGND pin also serves as return pin (ground pin) for VDDB. Keep SGND signal separated from the low voltage side power return terminal (–LO) in electrical design. | | | | | | | | |

| Address (ADDR) Pin | | | | | | | | |
|--|-------------------|------------------------|--------------------|-----------------------------|-----|-----|-----|---------------|
| <ul style="list-style-type: none"> This pin programs the address using a resistor between ADDR pin and signal ground. The address is sampled during startup and is stored until power is reset. This pin programs only a Fixed and Persistent address. This pin has an internal $10\text{k}\Omega$ pullup resistor to 3.3V. 16 addresses are available. The range of each address is 206.25mV (total range for all 16 addresses is 0V to 3.3V). | | | | | | | | |
| SIGNAL TYPE | STATE | ATTRIBUTE | SYMBOL | CONDITIONS / NOTES | MIN | TYP | MAX | UNIT |
| MULTI-LEVEL INPUT | Regular Operation | ADDR Input Voltage | V_{SADDR} | See address section | 0 | | 3.3 | V |
| | | ADDR Leakage Current | I_{SADDR} | Leakage current | | | 1 | μA |
| | Startup | ADDR Registration Time | t_{SADDR} | From $V_{\text{VDDB_MIN}}$ | | 1 | | ms |

Serial Clock input (SCL) AND Serial Data (SDA) Pins

- High power SMBus specification and SMBus physical layer compatible. Note that optional SMBALERT# is not supported.
- PMBus™ command compatible.

| SIGNAL TYPE | STATE | ATTRIBUTE | SYMBOL | CONDITIONS / NOTES | MIN | TYP | MAX | UNIT |
|----------------------|-------------------|---|-----------------|---|-----|-----|-----|---------|
| DIGITAL INPUT/OUTPUT | Regular Operation | Electrical Parameters | | | | | | |
| | | Input Voltage Threshold | V_{IH} | | 2.1 | | | V |
| | | | V_{IL} | | | 0.8 | | V |
| | | Output Voltage Threshold | V_{OH} | | 3 | | | V |
| | | | V_{OL} | | | 0.4 | | V |
| | | Leakage Current | I_{LEAK_PIN} | Unpowered device | | | 10 | μA |
| | | Signal Sink Current | I_{LOAD} | $V_{OL} = 0.4V$ | 4 | | | mA |
| | | Signal Capacitive Load | C_I | Total capacitive load of one device pin | | | 10 | pF |
| | | Signal Noise Immunity | V_{NOISE_PP} | 10MHz to 100MHz | 300 | | | mV |
| | | Timing Parameters | | | | | | |
| | | Operating Frequency | F_{SMB} | Idle state = 0Hz | 10 | | 400 | kHz |
| | | Free Time Between Stop and Start Condition | t_{BUF} | | 1.3 | | | μs |
| | | Hold Time After Start or Repeated Start Condition | $t_{HD:STA}$ | First clock is generated after this hold time | 0.6 | | | μs |
| | | Repeat Start Condition Setup Time | $t_{SU:STA}$ | | 0.6 | | | μs |
| | | Stop Condition Setup Time | $t_{SU:STO}$ | | 0.6 | | | μs |
| | | Data Hold Time | $t_{HD:DAT}$ | | 300 | | | ns |
| | | Data Setup Time | $t_{SU:DAT}$ | | 100 | | | ns |
| | | Clock Low Time Out | $t_{TIMEOUT}$ | | 25 | | 35 | ms |
| | | Clock Low Period | t_{LOW} | | 1.3 | | | μs |
| | | Clock High Period | t_{HIGH} | | 0.6 | | 50 | μs |
| | | Cumulative Clock Low Extend Time | $t_{LOW:SEXT}$ | | | | 25 | ms |
| | | Clock or Data Fall Time | t_f | | 20 | | 300 | ns |
| | | Clock or Data Rise Time | t_r | | 20 | | 300 | ns |

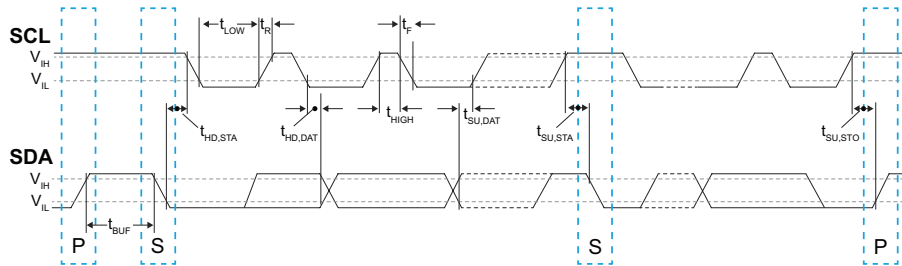

Timing Diagram (Forward Direction)

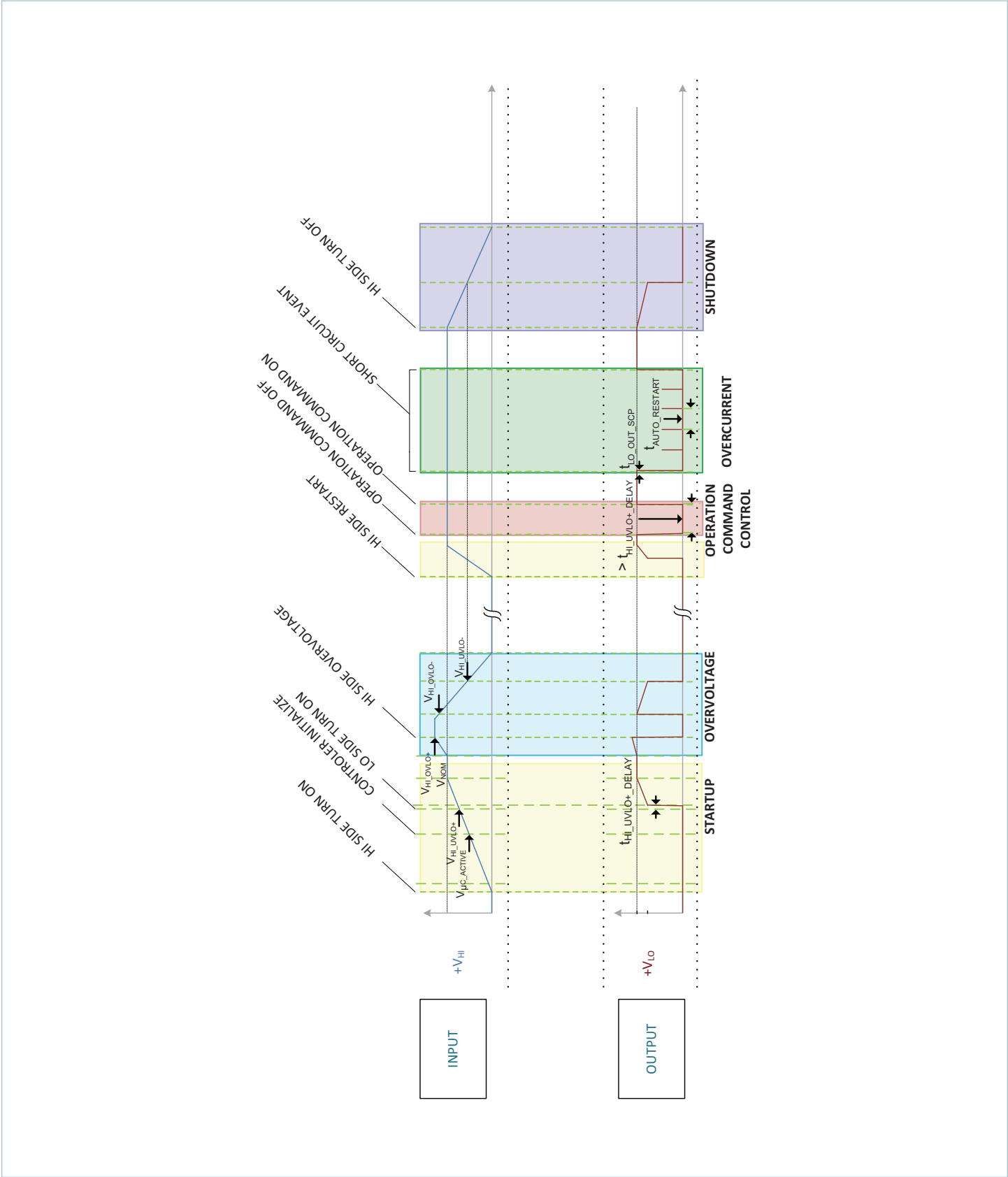

Application Characteristics

Temperature controlled via top side cold plate, unless otherwise noted. All data presented in this section are collected from units processing power in the forward direction (high voltage side to low voltage side). See associated figures for general trend data.

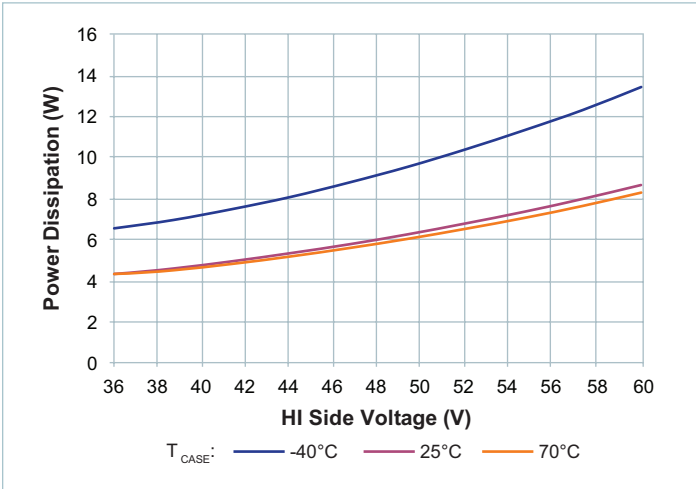

Figure 4 — No load power dissipation vs. V_{HI_DC}

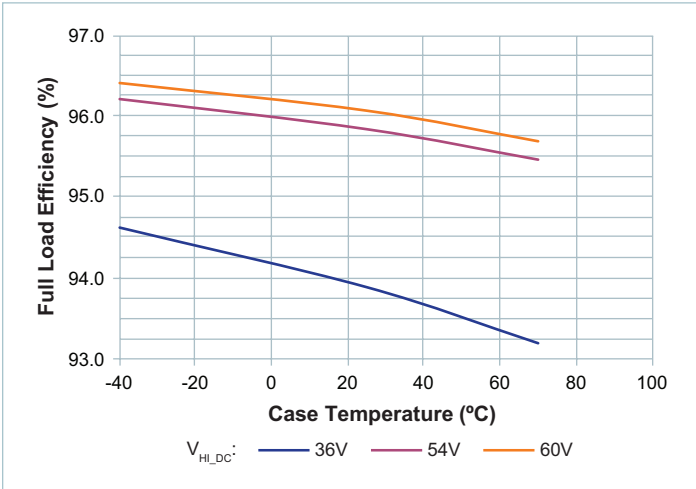

Figure 5 — Full load efficiency vs. temperature

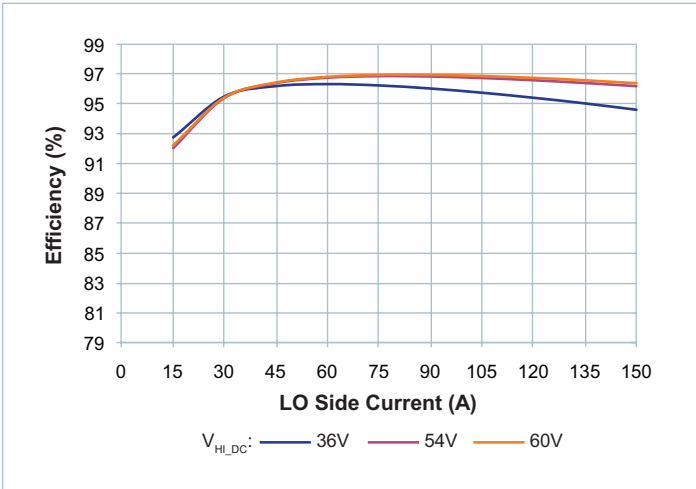

Figure 6 — Efficiency at $T_{CASE} = -40^{\circ}C$

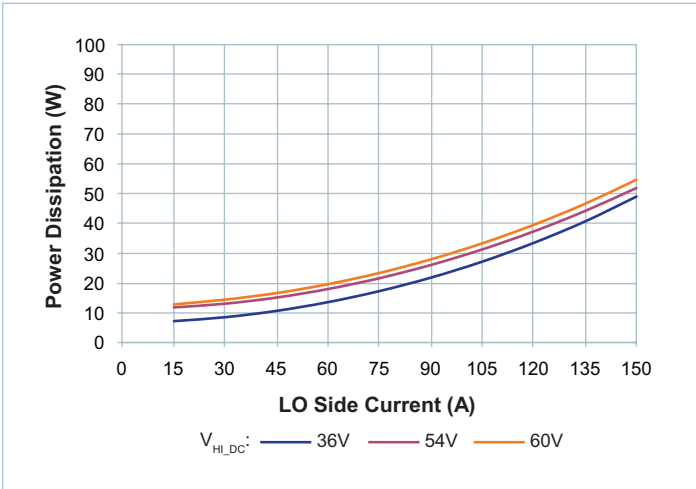

Figure 7 — Power dissipation at $T_{CASE} = -40^{\circ}C$

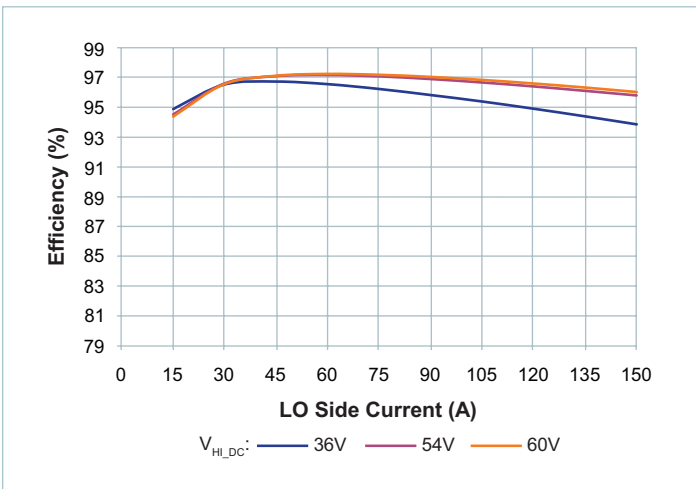

Figure 8 — Efficiency at $T_{CASE} = 25^{\circ}C$

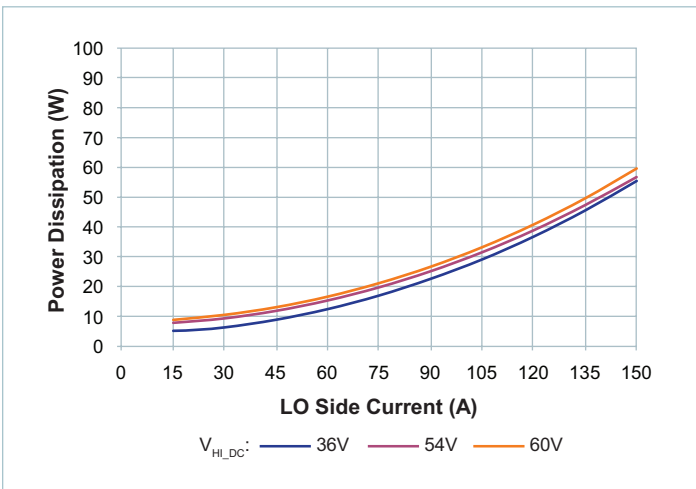

Figure 9 — Power dissipation at $T_{CASE} = 25^{\circ}C$

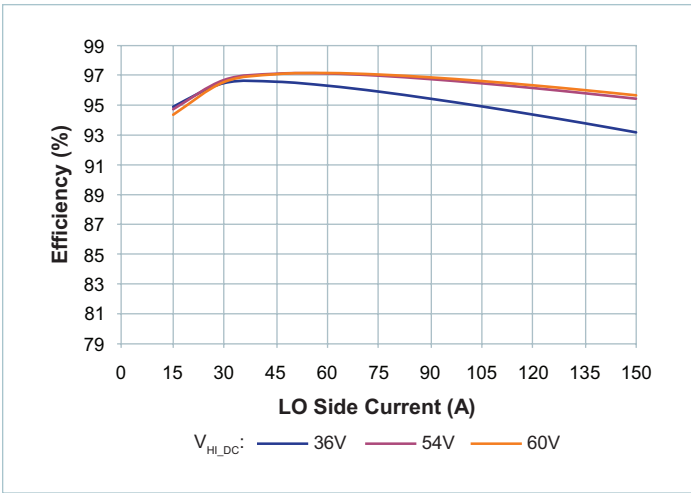

Figure 10 — Efficiency at $T_{CASE} = 0^{\circ}C$

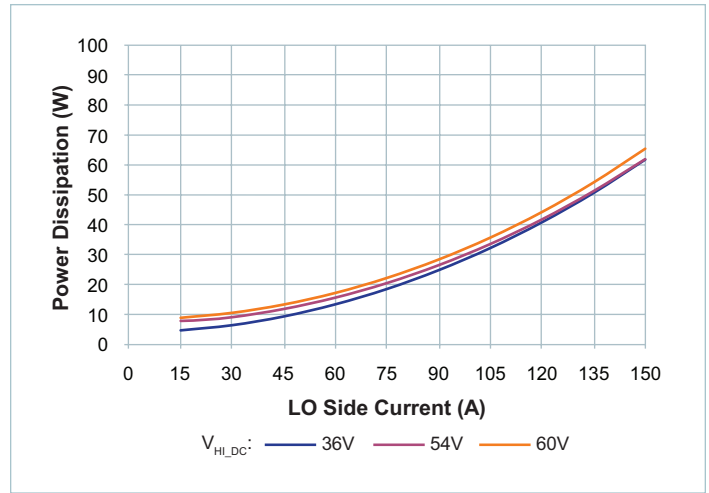

Figure 11 — Power dissipation at $T_{CASE} = 70^{\circ}C$

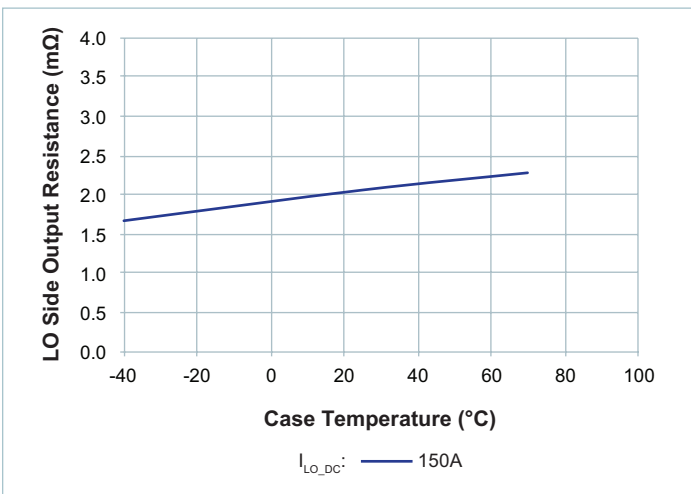

Figure 12 — R_{LO} vs. temperature; Nominal V_{HI_DC}
 $I_{LO_DC} = 150A$ at $T_{CASE} = 70^{\circ}C$

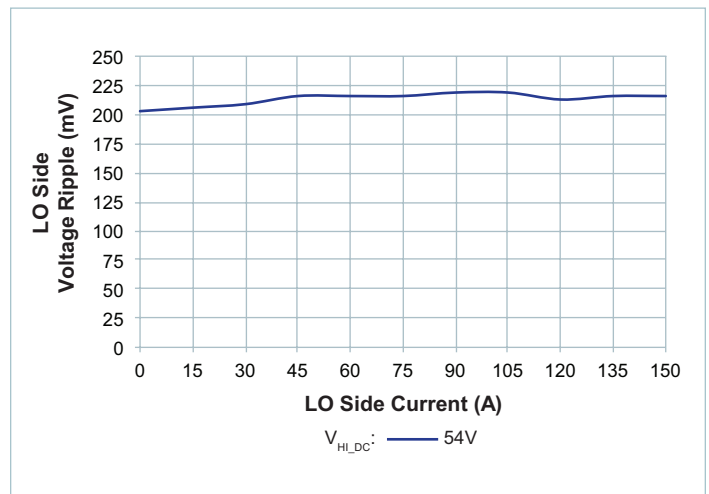

Figure 13 — $V_{LO_OUT_PP}$ vs. I_{LO_DC} ; No external $C_{LO_OUT_EXT}$. Board mounted module, scope setting: 20MHz analog BW

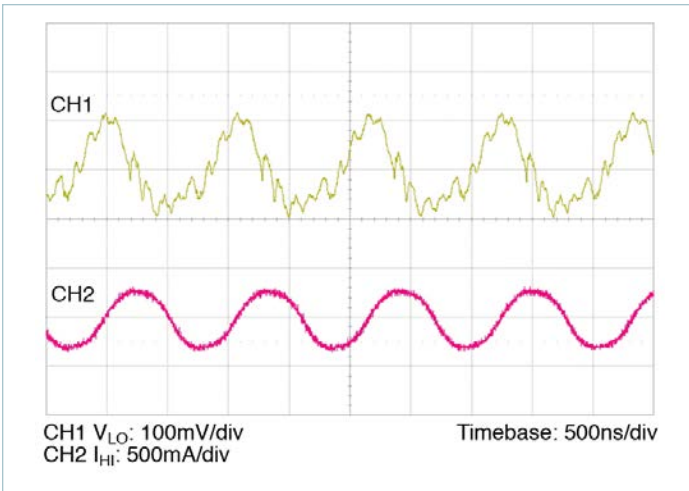

Figure 14 — Full load LO side voltage ripple, $300\mu\text{F } C_{HI_IN_EXT}$; no external $C_{LO_OUT_EXT}$. Board mounted module, scope setting: 20MHz analog BW

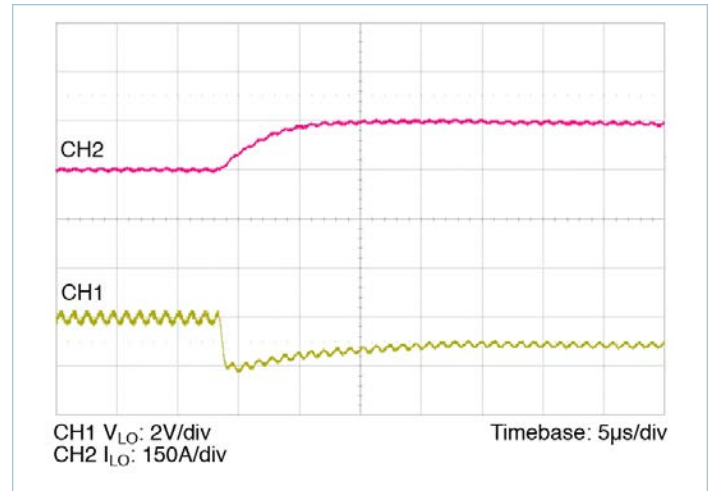

Figure 15 — 0A – 150A transient response: $C_{HI_IN_EXT} = 300\mu\text{F}$, no external $C_{LO_OUT_EXT}$

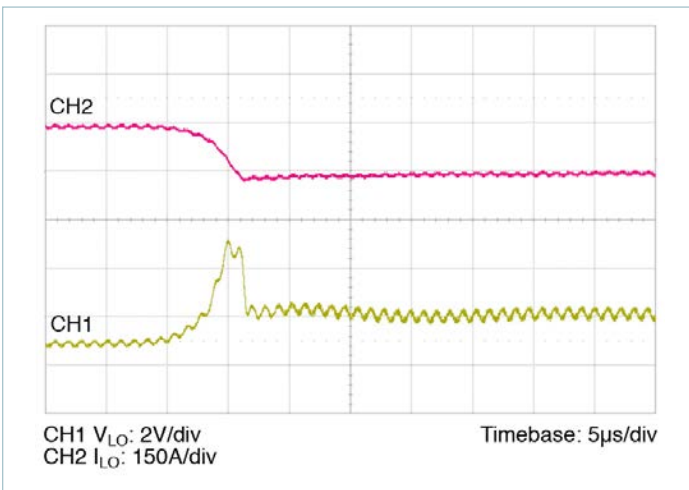

Figure 16 — 150A – 0A transient response: $C_{HI_IN_EXT} = 300\mu\text{F}$, no external $C_{LO_OUT_EXT}$

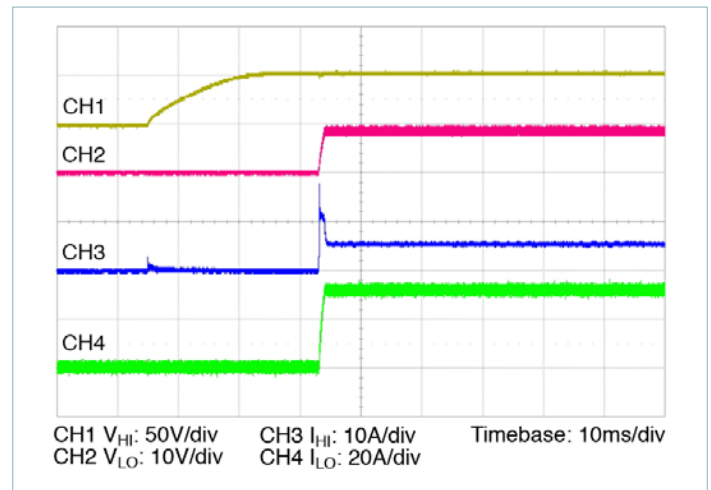

Figure 17 — Startup from application of $V_{HI_DC} = 54\text{V}$, 20% I_{LO_DC} 100% $C_{LO_OUT_EXT}$

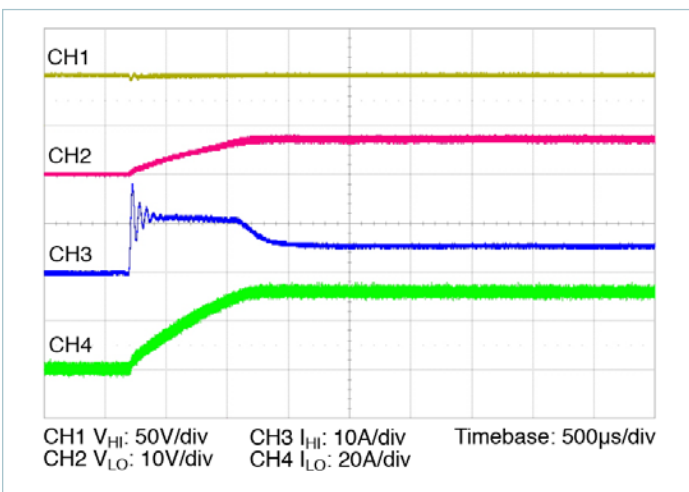

Figure 18 — Startup from application of OPERATION COMMAND with pre-applied $V_{HI_DC} = 54\text{V}$, 20% I_{LO_DC} 100% $C_{LO_OUT_EXT}$

General Characteristics

Specifications apply over all line and load conditions, unless otherwise noted; **boldface** specifications apply over the temperature range of -40°C ≤ T_{CASE} ≤ 100°C (T-Grade); All other specifications are at T_{CASE} = 25°C unless otherwise noted.

| Attribute | Symbol | Conditions / Notes | Min | Typ | Max | Unit | |
|--|----------------------|---|-----------------|----------------|-----------------|--------------------------------------|------|
| Mechanical | | | | | | | |
| Length | L | Lug (Chassis) Mount | 95.34 / [3.75] | 95.59 / [3.76] | 95.84 / [3.77] | mm / [in] | |
| Length | L | PCB (Board) Mount | 97.55 / [3.84] | 97.80 / [3.85] | 98.05 / [3.86] | mm / [in] | |
| Width | W | | 35.29 / [1.39] | 35.54 / [1.40] | 35.79 / [1.41] | mm / [in] | |
| Height | H | | 9.019 / [0.355] | 9.40 / [0.37] | 9.781 / [0.385] | mm / [in] | |
| Volume | Vol | Without heatsink | | 31.93 / [1.95] | | cm ³ / [in ³] | |
| Weight | W | | | 130.4 / [4.6] | | g / [oz] | |
| Pin Material | | C145 copper | | | | | |
| Underplate | | Low stress ductile Nickel | 50 | | 100 | μin | |
| Pin Finish (Gold) | | Palladium | 0.8 | | 6 | μin | |
| | | Soft Gold | 0.12 | | 2 | | |
| Pin Finish (Tin) | | Whisker resistant matte Tin | 200 | | 400 | μin | |
| Thermal | | | | | | | |
| Operating Internal Temperature | T _{INT} | BCM3814x60E10A5yzz (T-Grade) | -40 | | 125 | °C | |
| | | BCM3814x60E10A5yzz (C-Grade) | -20 | | 125 | | |
| Operating Case Temperature | T _{CASE} | BCM3814x60E10A5yzz (T-Grade), derating applied, see safe thermal operating area | -40 | | 100 | | |
| | | BCM3814x60E10A5yzz (C-Grade), derating applied, see safe thermal operating area | -20 | | 100 | | |
| Thermal Resistance Top Side | Φ _{INT_TOP} | Estimated thermal resistance to maximum temperature internal component from isothermal top | | 0.97 | | | °C/W |
| Thermal Resistance Coupling Between Top Case and Bottom Case | Φ _{HOU} | Estimated thermal resistance of thermal coupling between the top and bottom case surfaces | | 0.58 | | | °C/W |
| Thermal Resistance Bottom Side | Φ _{INT_BOT} | Estimated thermal resistance to maximum temperature internal component from isothermal bottom | | 0.59 | | °C/W | |
| Thermal Capacity | | | | 52 | | Ws/°C | |
| Assembly | | | | | | | |
| Storage Temperature | T _{ST} | BCM3814x60E10A5yzz (T-Grade) | -40 | | 125 | °C | |
| | | BCM3814x60E10A5yzz (C-Grade) | -40 | | 125 | °C | |
| ESD Withstand | ESD _{HBM} | Human Body Model, "ESDA / JEDEC JDS-001-2012" Class I-C (1kV to < 2kV) | 1000 | | | | |
| | ESD _{CDM} | Charge Device Model, "JESD 22-C101-E" Class II (200V to < 500V) | 200 | | | | |

General Characteristics (Cont.)

Specifications apply over all line and load conditions, unless otherwise noted; **boldface** specifications apply over the temperature range of $-40^{\circ}\text{C} \leq T_{\text{CASE}} \leq 100^{\circ}\text{C}$ (T-Grade); All other specifications are at $T_{\text{CASE}} = 25^{\circ}\text{C}$ unless otherwise noted.

| Attribute | Symbol | Conditions / Notes | Min | Typ | Max | Unit |
|------------------------------|---------------------|---|------------|------------|------------|------|
| Safety | | | | | | |
| Isolation Capacitance | $C_{\text{HI_LO}}$ | Unpowered unit | 620 | 780 | 940 | pF |
| Isolation Resistance | $R_{\text{HI_LO}}$ | At 500V _{DC} | 10 | | | MΩ |
| MTBF | | MIL-HDBK-217Plus Parts Count - 25°C Ground Benign, Stationary, Indoors / Computer | | 2.2 | | MHrs |
| | | Telcordia Issue 2 - Method I Case III; 25°C Ground Benign, Controlled | | 3.6 | | MHrs |
| Agency Approvals / Standards | | | | | | |
| | | | | | | |
| | | CE Marked for Low Voltage Directive and RoHS Recast Directive, as applicable | | | | |

BCM in a VIA Package

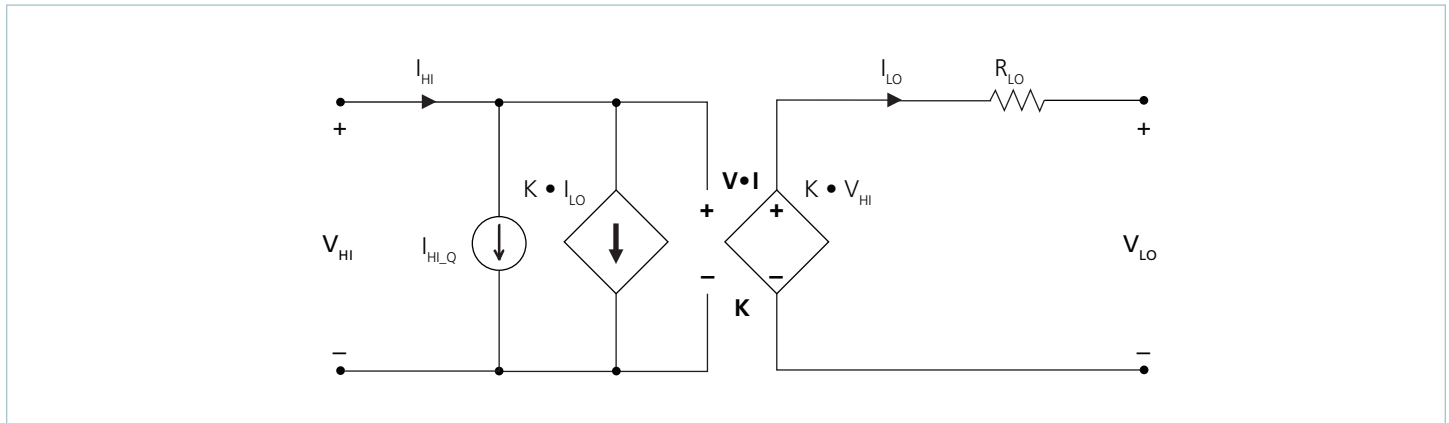

Figure 19 — BCM DC model (Forward Direction)

The BCM uses a high frequency resonant tank to move energy from the high voltage side to the low voltage side and vice versa. The resonant LC tank, operated at high frequency, is amplitude modulated as a function of the HI side voltage and the LO side current. A small amount of capacitance embedded in the high voltage side and low voltage side stages of the module is sufficient for full functionality and is key to achieving high power density.

The BCM3814x60E10A5yzz can be simplified into the model shown in Figure 19.

At no load:

$$V_{LO} = V_{HI} \cdot K \tag{1}$$

K represents the “turns ratio” of the BCM. Rearranging Eq (1):

$$K = \frac{V_{LO}}{V_{HI}} \tag{2}$$

In the presence of a load, V_{LO} is represented by:

$$V_{LO} = V_{HI} \cdot K - I_{LO} \cdot R_{LO} \tag{3}$$

and I_{LO} is represented by:

$$I_{LO} = \frac{I_{HI} - I_{HI,Q}}{K} \tag{4}$$

R_{LO} represents the impedance of the BCM and is a function of the R_{DS_ON} of the HI side and LO side MOSFETs, PC board resistance of HI side and LO side boards and the winding resistance of the power transformer. I_{HI,Q} represents the HI side quiescent current of the BCM controller, gate drive circuitry and core losses.

The effective DC voltage transformer action provides additional interesting attributes. Assuming that R_{LO} = 0Ω and I_{HI,Q} = 0A, Eq. (3) now becomes Eq. (1) and is essentially load independent, resistor R is now placed in series with V_{HI}.

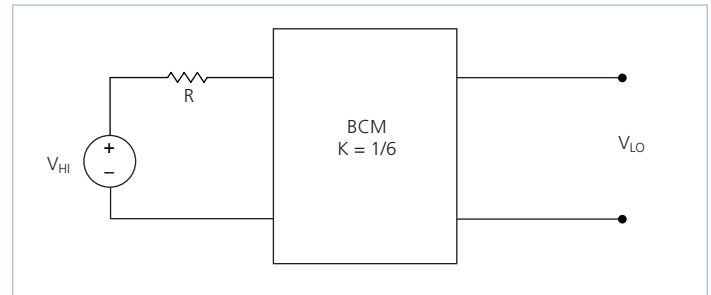

Figure 20 — K = 1/6 BCM with series HI side resistor

The relationship between V_{HI} and V_{LO} becomes:

$$V_{LO} = (V_{HI} - I_{HI} \cdot R) \cdot K \tag{5}$$

Substituting the simplified version of Eq. (4) (I_{HI,Q} is assumed = 0A) into Eq. (5) yields:

$$V_{LO} = V_{HI} \cdot K - I_{LO} \cdot R \cdot K^2 \tag{6}$$

This is similar in form to Eq. (3), where R_{LO} is used to represent the characteristic impedance of the BCM. However, in this case a real resistor, R, on the high voltage side of the BCM is effectively scaled by K² with respect to the low voltage side.

Assuming that R = 1Ω, the effective R as seen from the low voltage side is 28mΩ, with K = 1/6.

A similar exercise can be performed with the addition of a capacitor or shunt impedance at the high voltage side of the BCM. A switch in series with V_{HI} is added to the circuit. This is depicted in Figure 21.

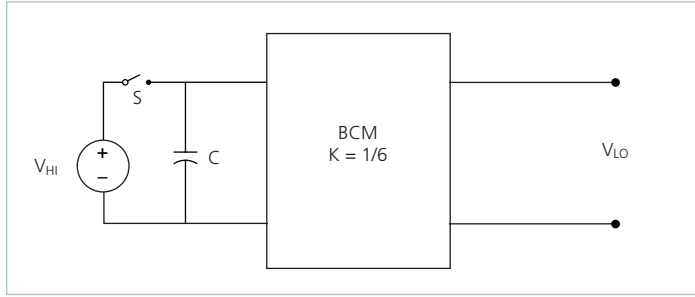

Figure 21 — BCM with HI side capacitor

A change in V_{HI} with the switch closed would result in a change in capacitor current according to the following equation:

$$I_C(t) = C \frac{dV_{HI}}{dt} \quad (7)$$

Assume that with the capacitor charged to V_{HI} , the switch is opened and the capacitor is discharged through the idealized BCM. In this case,

$$I_C = I_{LO} \cdot K \quad (8)$$

substituting Eq. (1) and (8) into Eq. (7) reveals:

$$I_{LO}(t) = \frac{C}{K^2} \cdot \frac{dV_{LO}}{dt} \quad (9)$$

The equation in terms of the LO side has yielded a K^2 scaling factor for C , specified in the denominator of the equation.

A K factor less than unity results in an effectively larger capacitance on the low voltage side when expressed in terms of the high voltage side. With a $K = 1/6$ as shown in Figure 21, $C = 1\mu\text{F}$ would appear as $C = 36\mu\text{F}$ when viewed from the low voltage side.

Low impedance is a key requirement for powering a high-current, low-voltage load efficiently. A switching regulation stage should have minimal impedance while simultaneously providing appropriate filtering for any switched current. The use of a BCM between the regulation stage and the point of load provides a dual benefit of scaling down series impedance leading back to the source and scaling up shunt capacitance or energy storage as a function of its K factor squared. However, these benefits are not achieved if the series impedance of the BCM is too high. The impedance of the BCM must be low, i.e., well beyond the crossover frequency of the system.

A solution for keeping the impedance of the BCM low involves switching at a high frequency. This enables the use of small magnetic components because magnetizing currents remain low. Small magnetics mean small path lengths for turns. Use of low loss core material at high frequencies also reduces core losses.

The two main terms of power loss in the BCM module are:

- No load power dissipation (P_{HI_NL}): defined as the power used to power up the module with an enabled powertrain at no load.
- Resistive loss ($P_{R_{LO}}$): refers to the power loss across the BCM module modeled as pure resistive impedance.

Therefore,

$$P_{DISSIPATED} = P_{HI_NL} + P_{R_{LO}} \quad (10)$$

The above relations can be combined to calculate the overall module efficiency:

$$P_{LO_OUT} = P_{HI_IN} - P_{DISSIPATED} = P_{HI_IN} - P_{HI_NL} - P_{R_{LO}} \quad (11)$$

$$\eta = \frac{P_{LO_OUT}}{P_{HI_IN}} = \frac{P_{HI_IN} - P_{HI_NL} - P_{R_{LO}}}{P_{HI_IN}} \quad (12)$$

$$= \frac{V_{HI} \cdot I_{HI} - P_{HI_NL} - (I_{LO})^2 \cdot R_{LO}}{V_{HI} \cdot I_{HI}}$$

$$= 1 - \left(\frac{P_{HI_NL} + (I_{LO})^2 \cdot R_{LO}}{V_{HI} \cdot I_{HI}} \right)$$

Filter Design

A major advantage of BCM systems versus conventional PWM converters is that the transformer based BCM does not require external filtering to function properly. The resonant LC tank, operated at extreme high frequency, is amplitude modulated as a function of HI side voltage and LO side current and efficiently transfers charge through the isolation transformer. A small amount of capacitance embedded in the high voltage side and low voltage side stages of the module is sufficient for full functionality and is key to achieving power density.

This paradigm shift requires system design to carefully evaluate external filters in order to:

- **Guarantee low source impedance:**

To take full advantage of the BCM module’s dynamic response, the impedance presented to its HI side terminals must be low from DC to approximately 5MHz. The connection of the bus converter module to its power source should be implemented with minimal distribution inductance. If the interconnect inductance exceeds 100nH, the HI side should be bypassed with a RC damper to retain low source impedance and stable operation. With an interconnect inductance of 200nH, the RC damper may be as high as 1μF in series with 0.3Ω. A single electrolytic or equivalent low-Q capacitor may be used in place of the series RC bypass.

- **Further reduce HI side and/or LO side voltage ripple without sacrificing dynamic response:**

Given the wide bandwidth of the module, the source response is generally the limiting factor in the overall system response. Anomalies in the response of the source will appear at the LO side of the module multiplied by its K factor.

- **Protect the module from overvoltage transients imposed by the system that would exceed maximum ratings and induce stresses:**

The module high side/low side voltage ranges shall not be exceeded. An internal overvoltage lockout function prevents operation outside of the normal operating HI side range. Even when disabled, the powertrain is exposed to the applied voltage and the power MOSFETs must withstand it.

Total load capacitance at the LO side of the BCM module shall not exceed the specified maximum. Owing to the wide bandwidth and small LO side impedance of the module, low-frequency bypass capacitance and significant energy storage may be more densely and efficiently provided by adding capacitance at the HI side of the module. At frequencies <500kHz the module appears as an impedance of R_{LO} between the source and load.

Within this frequency range, capacitance at the HI side appears as effective capacitance on the LO side per the relationship defined in Eq. (13).

$$C_{LO_EXT} = \frac{C_{HI_EXT}}{K^2} \tag{13}$$

This enables a reduction in the size and number of capacitors used in a typical system.

Thermal Considerations

The VIA package provides effective conduction cooling from either of the two module surfaces. Heat may be removed from the top surface, the bottom surface or both. The extent to which these two surfaces are cooled is a key component for determining the maximum power that can be processed by a VIA, as can be seen from the specified thermal operating area in Figure 1. Since the VIA has a maximum internal temperature rating, it is necessary to estimate this internal temperature based on a system-level thermal solution. For this purpose, it is helpful to simplify the thermal solution into a roughly equivalent circuit where power dissipation is modeled as a current source, isothermal surface temperatures are represented as voltage sources and the thermal resistances are represented as resistors. Figure 22 shows the “thermal circuit” for the VIA module.

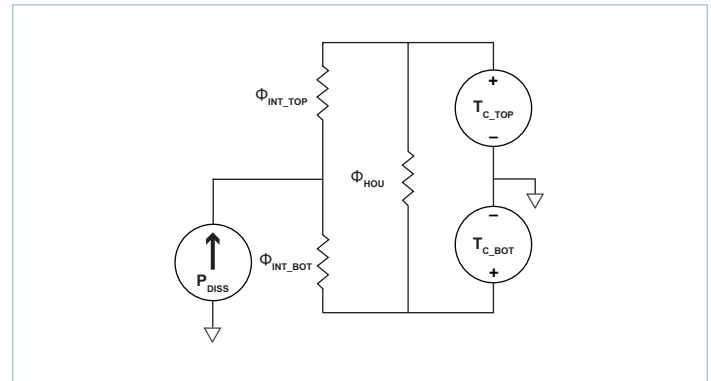

Figure 22 — Double-sided cooling VIA thermal model

In this case, the internal power dissipation is P_{DISS}, Φ_{INT_TOP} and Φ_{INT_BOT} are the thermal resistance characteristics of the VIA module and the top and bottom surface temperatures are represented as T_{C_TOP} and T_{C_BOT}. It is interesting to note that the package itself provides a high degree of thermal coupling between the top and bottom case surfaces (represented in the model by the resistor Φ_{HOU}). This feature enables two main options regarding thermal designs:

- Single side cooling: the model of Figure 22 can be simplified by calculating the parallel resistor network and using one simple thermal resistance number and the internal power dissipation curves; an example for bottom side cooling only is shown in Figure 23.

In this case, Φ_{INT} can be derived as follows:

$$\Phi_{INT} = \frac{(\Phi_{INT_TOP} + \Phi_{HOU}) \cdot \Phi_{INT_BOT}}{\Phi_{INT_TOP} + \Phi_{HOU} + \Phi_{INT_BOT}} \tag{14}$$

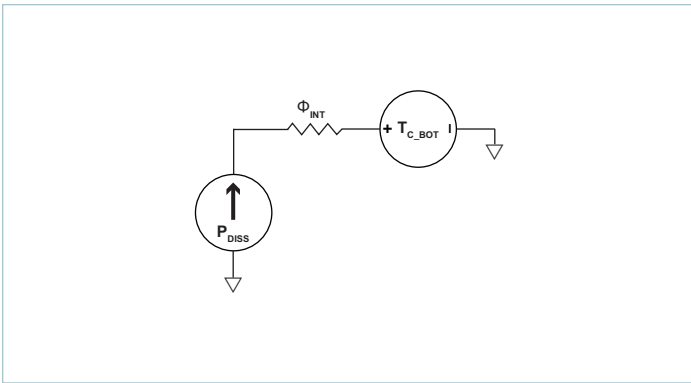

Figure 23 — Single-sided cooling VIA thermal model

- Double side cooling: while this option might bring limited advantage to the module internal components (given the surface-to-surface coupling provided), it might be appealing in cases where the external thermal system requires allocating power to two different elements, such as heatsinks with independent airflows or a combination of chassis/air cooling.

Current Sharing

The performance of the BCM is based on efficient transfer of energy through a transformer without the need of closed loop control. For this reason, the transfer characteristic can be approximated by an ideal transformer with a positive temperature coefficient series resistance.

This type of characteristic is close to the impedance characteristic of a DC power distribution system both in dynamic (AC) behavior and for steady state (DC) operation.

When multiple BCM modules of a given part number are connected in an array, they will inherently share the load current according to the equivalent impedance divider that the system implements from the power source to the point of load. Ensuring equal current sharing among modules requires that BCM array impedances be matched.

Some general recommendations to achieve matched array impedances include:

- Dedicate common copper planes/wires within the PCB/Chassis to deliver and return the current to the modules.
- Provide as symmetric a PCB/Wiring layout as possible among modules

For further details see [AN:016 Using BCM Bus Converters in High Power Arrays.](#)

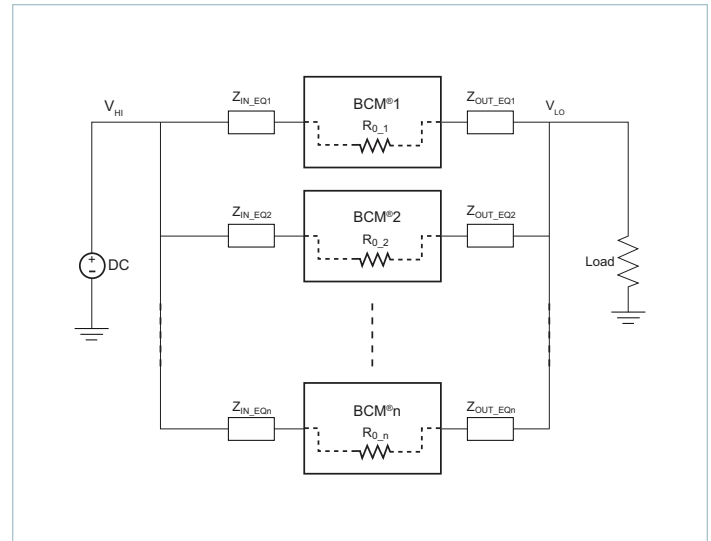

Figure 24 — BCM module array

Fuse Selection

In order to provide flexibility in configuring power systems, BCM in a VIA package modules are not internally fused. Input line fusing of BCM products is recommended at the system level to provide thermal protection in case of catastrophic failure.

The fuse shall be selected by closely matching system requirements with the following characteristics:

- Current rating (usually greater than maximum current of BCM module)
- Maximum voltage rating (usually greater than the maximum possible input voltage)
- Ambient temperature
- Nominal melting I^2t
- Recommend fuse: $\leq 40A$ Littlefuse 456 Series (HI side)

Reverse Operation

BCM modules are capable of reverse power operation. Once the unit is started, energy will be transferred from the low voltage side back to the high voltage side whenever the low side voltage exceeds $V_{HI} \cdot K$. The module will continue operation in this fashion as long as no faults occur.

The BCM3814x60E10A5yzz has not been qualified for continuous operation in a reverse power condition. However, fault protections that help to protect the module in forward operation will also protect the module in reverse operation.

Transient operation in reverse is expected in cases where there is significant energy storage on the low voltage side and transient voltages appear on the high voltage side.

System Diagram for PMBus™ Interface

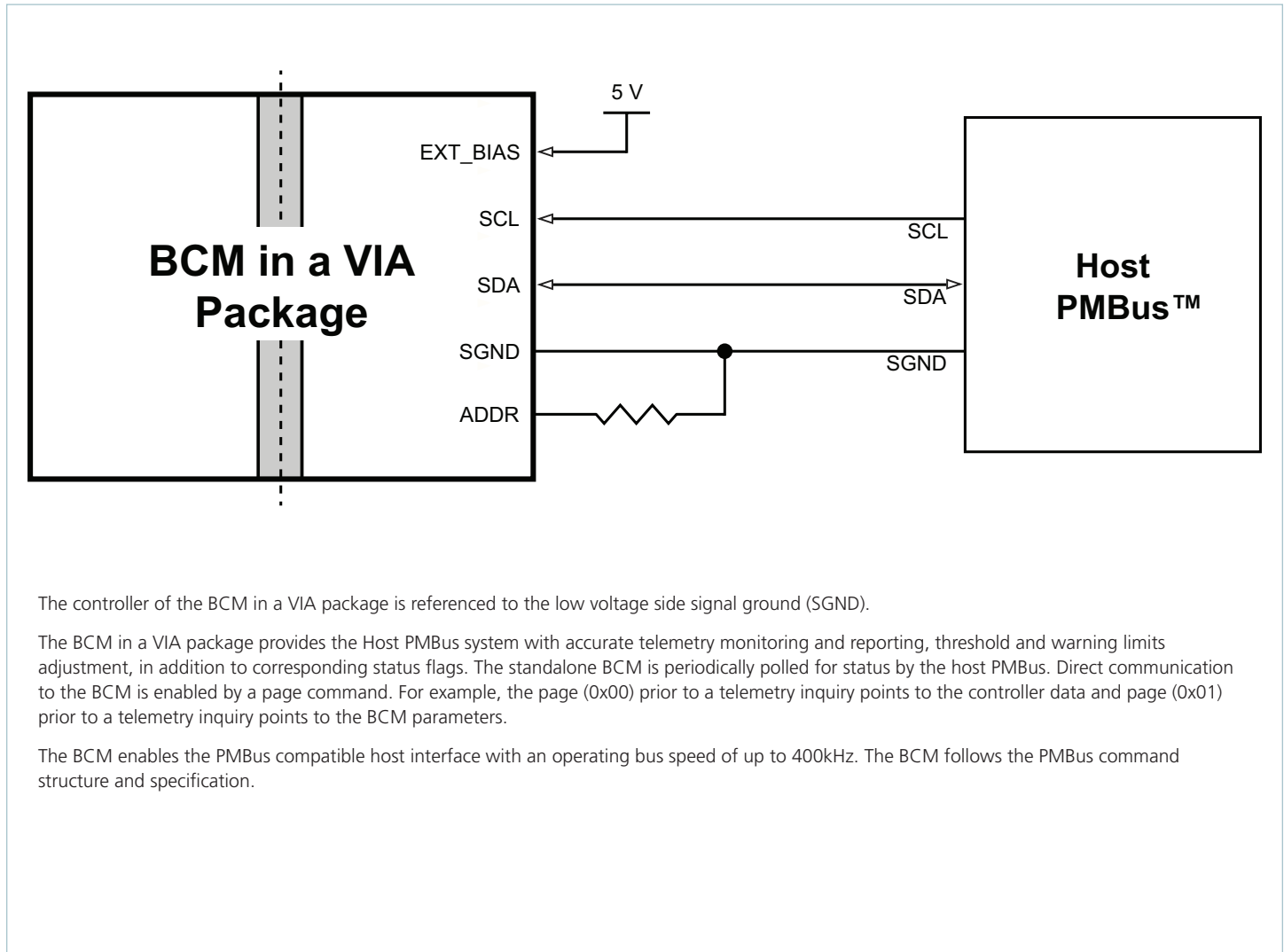

PMBus™ Interface

Refer to “PMBus Power System Management Protocol Specification Revision 1.2, Part I and II” for complete PMBus specifications details at <http://pmbus.org>.

Device Address

The PMBus address (ADDR Pin) should be set to one of the predetermined 16 possible addresses shown in the table below using a resistor between the ADDR pin and SGND pin.

The BCM accepts only a fixed and persistent address and does not support SMBus address resolution protocol. At initial power up, the BCM controller will sample the address pin voltage and will keep this address until device power is removed.

| ID | Slave Address | HEX | Recommended Resistor R _{ADDR} (Ω) |
|----|---------------|-----|--|
| 1 | 1010 000b | 50h | 487 |
| 2 | 1010 001b | 51h | 1050 |
| 3 | 1010 010b | 52h | 1870 |
| 4 | 1010 011b | 53h | 2800 |
| 5 | 1010 100b | 54h | 3920 |
| 6 | 1010 101b | 55h | 5230 |
| 7 | 1010 110b | 56h | 6810 |
| 8 | 1010 111b | 57h | 8870 |
| 9 | 1011 000b | 58h | 11300 |
| 10 | 1011 001b | 59h | 14700 |
| 11 | 1011 010b | 5Ah | 19100 |
| 12 | 1011 011b | 5Bh | 25500 |
| 13 | 1011 100b | 5Ch | 35700 |
| 14 | 1011 101b | 5Dh | 53600 |
| 15 | 1011 110b | 5Eh | 97600 |
| 16 | 1011 111b | 5Fh | 316000 |

Reported DATA Formats

The BCM controller employs a direct data format where all reported measurements are in Volts, Amperes, Degrees Celsius, or Seconds. The host uses the following PMBus specification to interpret received values metric prefixes. Note that the COEFFICIENTS command is not supported:

$$X = \left(\frac{1}{m}\right) \cdot (Y \cdot 10^R - b)$$

Where:

X, is a “real world” value in units (A, V, °C, s)

Y, is a two’s complement integer received from the BCM controller

m, b and R are two’s complement integers defined as follows:

| Command | Code | m | R | b |
|-----------------------------------|------|-------|---|---|
| TON_DELAY | 60h | 1 | 3 | 0 |
| READ_VIN | 88h | 1 | 1 | 0 |
| READ_IIN | 89h | 1 | 3 | 0 |
| READ_VOUT ^[1] | 8Bh | 1 | 1 | 0 |
| READ_IOUT | 8Ch | 1 | 2 | 0 |
| READ_TEMPERATURE_1 ^[2] | 8Dh | 1 | 0 | 0 |
| READ_POUT | 96h | 1 | 0 | 0 |
| MFR_VIN_MIN | A0h | 1 | 0 | 0 |
| MFR_VIN_MAX | A1h | 1 | 0 | 0 |
| MFR_VOUT_MIN | A4h | 1 | 0 | 0 |
| MFR_VOUT_MAX | A5h | 1 | 0 | 0 |
| MFR_IOUT_MAX | A6h | 1 | 0 | 0 |
| MFR_POUT_MAX | A7h | 1 | 0 | 0 |
| READ_K_FACTOR | D1h | 65536 | 0 | 0 |
| READ_BCM_ROUT | D4h | 1 | 5 | 0 |

^[1] Default READ LO side voltage returned when BCM unit is disabled = -300V.

^[2] Default READ Temperature returned when BCM unit is disabled = -273°C.

No special formatting is required when lowering the supervisory limits and warnings.

Supported Command List

| Command | Code | Function | Default Data Content | Data Bytes |
|---------------------|--------------------|---|----------------------|------------|
| PAGE | 00h | Access BCM stored information | 00h | 1 |
| OPERATION | 01h | Turn BCM on or off | 80h | 1 |
| CLEAR_FAULTS | 03h | Clear all faults | N/A | None |
| CAPABILITY | 19h | Controller PMBus™ key capabilities set by factory | 20h | 1 |
| OT_FAULT_LIMIT | 4Fh ^[1] | Overtemperature protection | 64h | 2 |
| OT_WARN_LIMIT | 51h ^[1] | Overtemperature warning | 64h | 2 |
| VIN_OV_FAULT_LIMIT | 55h ^[1] | High voltage side overvoltage protection | 64h | 2 |
| VIN_OV_WARN_LIMIT | 57h ^[1] | High voltage side overvoltage warning | 64h | 2 |
| IIN_OC_FAULT_LIMIT | 5Bh ^[1] | High voltage side overcurrent protection | 64h | 2 |
| IIN_OC_WARN_LIMIT | 5Dh ^[1] | High voltage side overcurrent warning | 64h | 2 |
| TON_DELAY | 60h ^[1] | Startup delay in addition to fixed delay | 00h | 2 |
| STATUS_BYTE | 78h | Summary of faults | 00h | 1 |
| STATUS_WORD | 79h | Summary of fault conditions | 00h | 2 |
| STATUS_IOUT | 7Bh | Overcurrent fault status | 00h | 1 |
| STATUS_INPUT | 7Ch | Overvoltage and undervoltage fault status | 00h | 1 |
| STATUS_TEMPERATURE | 7Dh | Overtemperature and undertemperature fault status | 00h | 1 |
| STATUS_CML | 7Eh | PMBus communication fault | 00h | 1 |
| STATUS_MFR_SPECIFIC | 80h | Other BCM status indicator | 00h | 1 |
| READ_VIN | 88h | Reads HI side voltage | FFFFh | 2 |
| READ_IIN | 89h | Reads HI side current | FFFFh | 2 |
| READ_VOUT | 8Bh | Reads LO side voltage | FFFFh | 2 |
| READ_IOUT | 8Ch | Reads LO side current | FFFFh | 2 |
| READ_TEMPERATURE_1 | 8Dh | Reads internal temperature | FFFFh | 2 |
| READ_POUT | 96h | Reads LO side power | FFFFh | 2 |
| PMBUS_REVISION | 98h | PMBus compatible revision | 22h | 1 |
| MFR_ID | 99h | BCM controller ID | “VI” | 2 |
| MFR_MODEL | 9Ah | Internal controller or BCM model | Part Number | 18 |
| MFR_REVISION | 9Bh | Internal controller or BCM revision | FW and HW revision | 18 |
| MFR_LOCATION | 9Ch | Internal controller or BCM factory location | “AP” | 2 |
| MFR_DATE | 9Dh | Internal controller or BCM manufacturing date | “YYWW” | 4 |
| MFR_SERIAL | 9Eh | Internal controller or BCM serial number | Serial Number | 16 |
| MFR_VIN_MIN | A0h | Minimum rated high side voltage | Varies per BCM | 2 |
| MFR_VIN_MAX | A1h | Maximum rated high side voltage | Varies per BCM | 2 |
| MFR_VOUT_MIN | A4h | Minimum rated low side voltage | Varies per BCM | 2 |
| MFR_VOUT_MAX | A5h | Maximum rated low side voltage | Varies per BCM | 2 |
| MFR_IOUT_MAX | A6h | Maximum rated low side current | Varies per BCM | 2 |
| MFR_POUT_MAX | A7h | Maximum rated low side power | Varies per BCM | 2 |
| READ_K_FACTOR | D1h | Reads K factor | Varies per BCM | 2 |
| READ_BCM_ROUT | D4h | Reads low voltage side output resistance | Varies per BCM | 2 |
| SET_ALL_THRESHOLDS | D5h ^[1] | Set supervisory warning and protection thresholds | 646464646464h | 6 |
| DISABLE_FAULT | D7h ^[1] | Disable overvoltage, overcurrent or undervoltage supervisory faults | 00h | 2 |

^[1] The BCM must be in a disabled state with $V_{HI} < V_{HI_UVLO}$, and VDDB applied during a write message.

Command Structure Overview

Write Byte protocol:

The Host always initiates PMBus™ communication with a START bit. All messages are terminated by the Host with a STOP bit. In a write message, the master sends the slave device address followed by a write bit. Once the slave acknowledges, the master proceeds with the command code and then similarly the data byte.

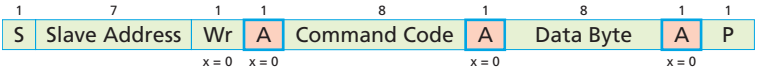

- S** Start Condition
- Sr** Repeated start Condition
- Rd** Read
- Wr** Write
- X** Indicated that field is required to have the value of x
- A** Acknowledge (bit may be 0 for an ACK or 1 for a NACK)
- P** Stop Condition
- From Master to Slave
- From Slave to Master
- ... Continued next line

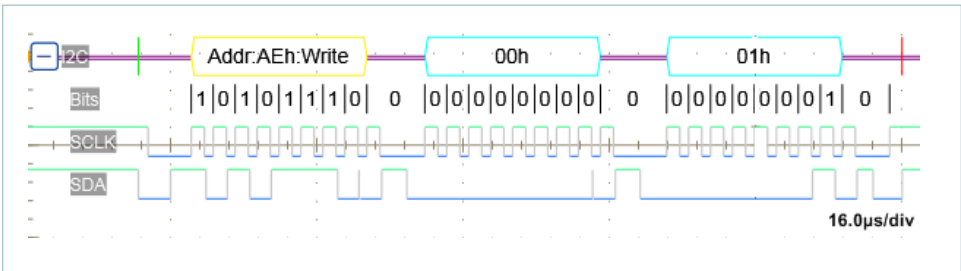

Figure 1 — PAGE COMMAND (00h), WRITE BYTE PROTOCOL

Read Byte protocol:

A Read message begins by first sending a Write Command, followed by a REPEATED START Bit and a slave Address. After receiving the READ bit, the BCM controller begins transmission of the Data responding to the Command. Once the Host receives the requested Data, it terminates the message with a NACK preceding a stop condition signifying the end of a read transfer.

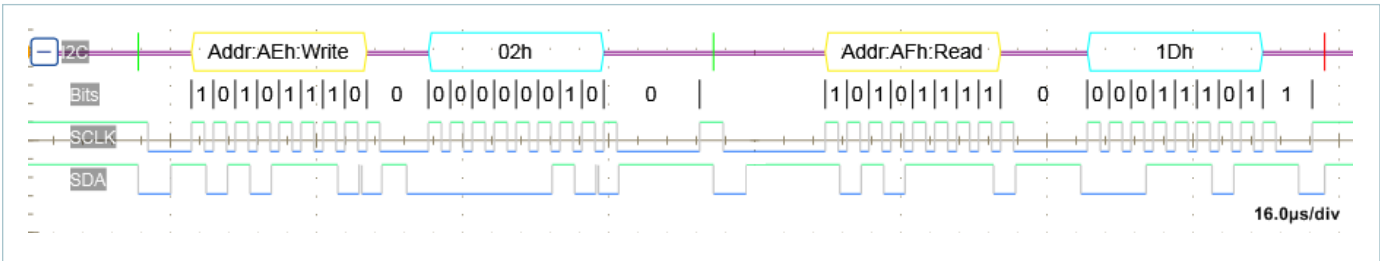
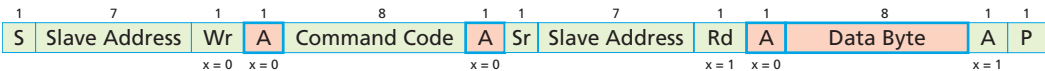

Figure 2 — ON_OFF_CONFIG COMMAND (02h), READ BYTE PROTOCOL

Write Word protocol:

When transmitting a word, the lowest order byte leads the highest order byte. Furthermore, when transmitting a Byte, the least significant bit (LSB) is sent last. Refer to System Management Bus (SMBus) specification version 2.0 for more details.

Note: Extended command and Packet Error Checking Protocols are not supported.

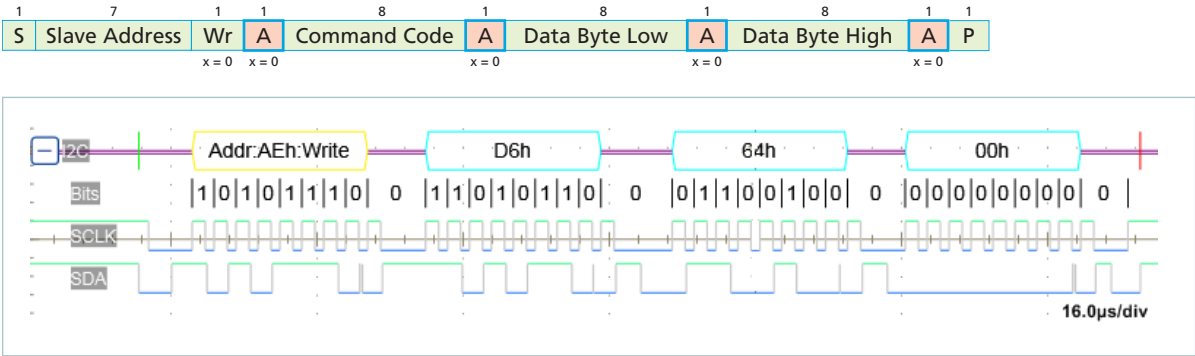

Figure 3 — TON_DELAY COMMAND (D6h)_WRITE WORD PROTOCOL

Read Word protocol:

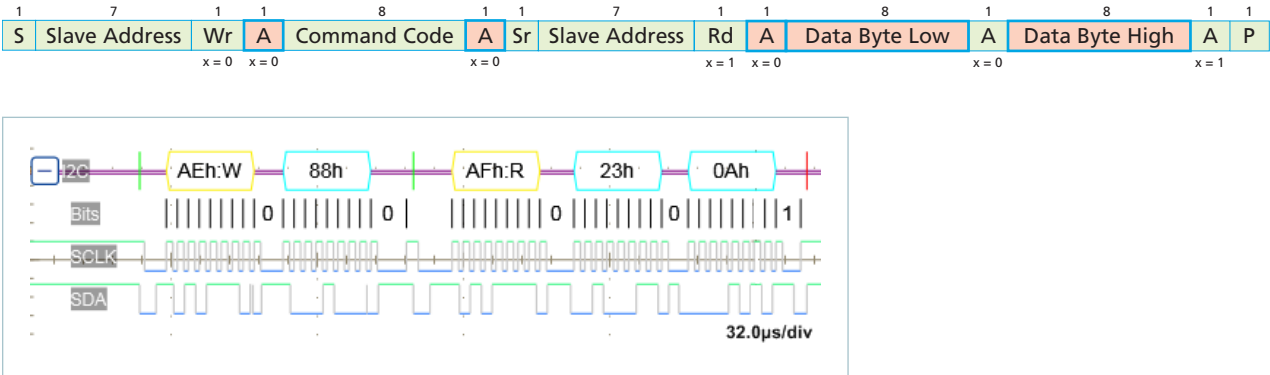

Figure 4 — MFR_VIN_MIN COMMAND (88h)_READ WORD PROTOCOL

Write Block protocol:

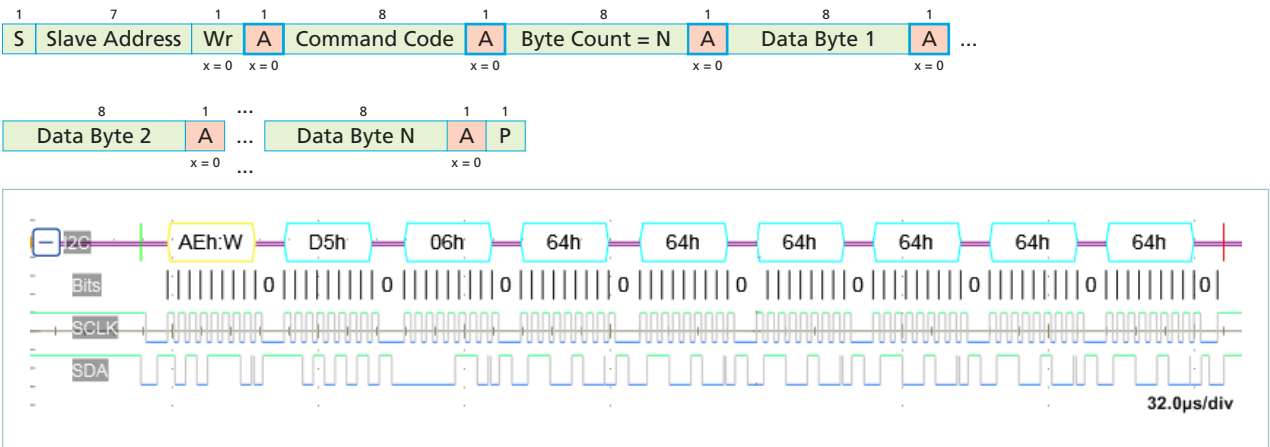

Figure 5 — SET_ALL_THRESHOLDS COMMAND (D5h)_WRITE BLOCK PROTOCOL

Read Block protocol:

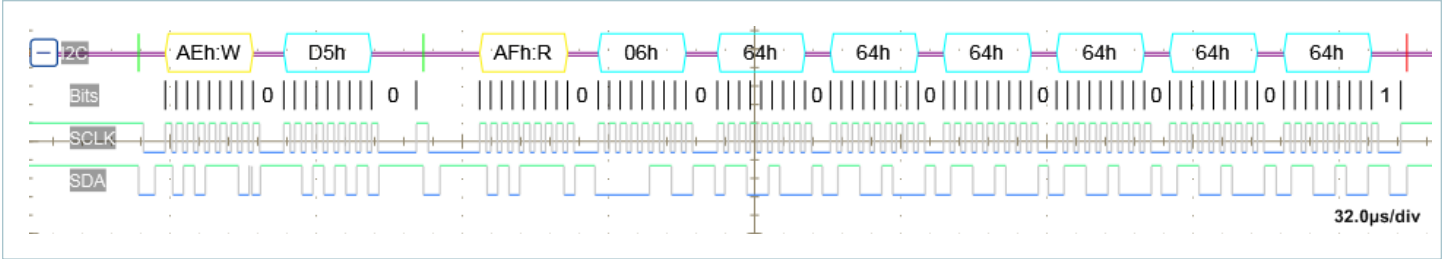
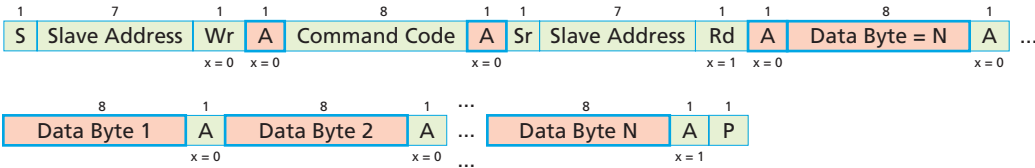

Figure 6 — SET_ALL_THRESHOLDS COMMAND (D5h)_READ BLOCK PROTOCOL

Write Group Command protocol:

Note that only one command per device is allowed in a group command.

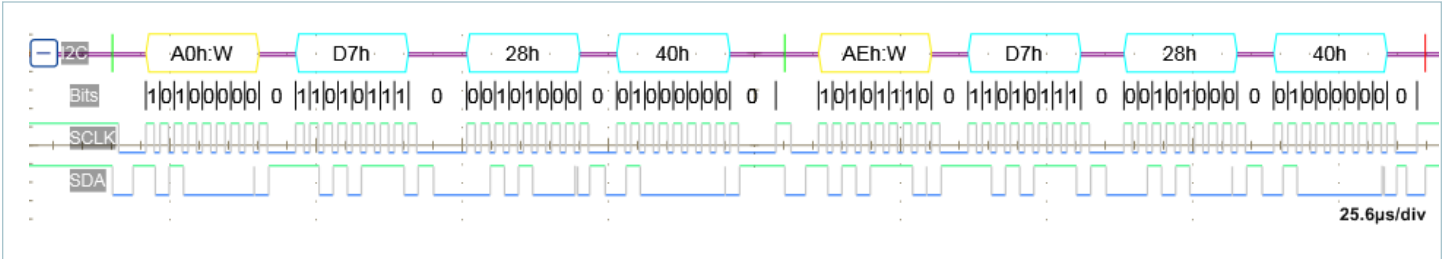
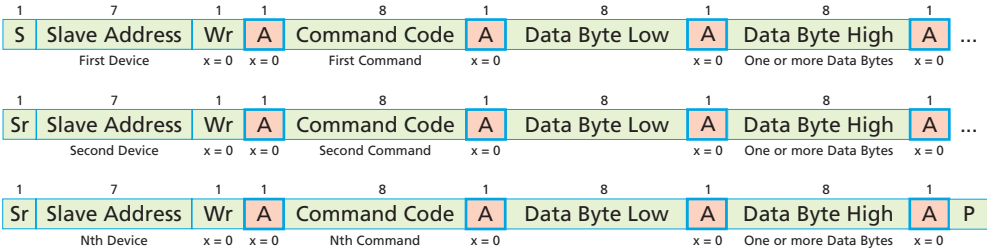

Figure 7 — DISABLE_FAULT COMMAND (D7h)_WRITE

Supported Commands Transaction Type

A direct communication to the BCM controller and a simulated communication to non-PMBus™ devices is enabled by a page command. Supported command access privileges with a pre-selected PAGE are defined in the following table. Deviation from this table generates a communication error in STATUS_CML register.

| Command | Code | PAGE Data Byte Access Type | |
|---------------------|------|----------------------------|-----|
| | | 00h | 01h |
| PAGE | 00h | R/W | R/W |
| OPERATION | 01h | R | R/W |
| CLEAR_FAULTS | 03h | W | W |
| CAPABILITY | 19h | R | |
| OT_FAULT_LIMIT | 4Fh | | R/W |
| OT_WARN_LIMIT | 51h | | R/W |
| VIN_OV_FAULT_LIMIT | 55h | | R/W |
| VIN_OV_WARN_LIMIT | 57h | | R/W |
| IIN_OC_FAULT_LIMIT | 5Bh | | R/W |
| IIN_OC_WARN_LIMIT | 5Dh | | R/W |
| TON_DELAY | 60h | | R/W |
| STATUS_BYTE | 78h | R/W | R |
| STATUS_WORD | 79h | R | R |
| STATUS_IOUT | 7Bh | R | R/W |
| STATUS_INPUT | 7Ch | R | R/W |
| STATUS_TEMPERATURE | 7Dh | R | R/W |
| STATUS_CML | 7Eh | R/W | |
| STATUS_MFR_SPECIFIC | 80h | R | R/W |
| READ_VIN | 88h | | R |
| READ_IIN | 89h | R | R |
| READ_VOUT | 8Bh | | R |
| READ_IOUT | 8Ch | R | R |
| READ_TEMPERATURE_1 | 8Dh | R | R |
| READ_POUT | 96h | R | R |
| PMBUS_REVISION | 98h | R | |
| MFR_ID | 99h | R | |
| MFR_MODEL | 9Ah | R | R |
| MFR_REVISION | 9Bh | R | R |
| MFR_LOCATION | 9Ch | R | R |
| MFR_DATE | 9Dh | R | R |
| MFR_SERIAL | 9Eh | R | R |
| MFR_VIN_MIN | A0h | R | R |
| MFR_VIN_MAX | A1h | R | R |
| MFR_VOUT_MIN | A4h | R | R |
| MFR_VOUT_MAX | A5h | R | R |
| MFR_IOUT_MAX | A6h | R | R |
| MFR_POUT_MAX | A7h | R | R |
| READ_K_FACTOR | D1h | | R |
| READ_BCM_ROUT | D4h | | R |
| SET_ALL_THRESHOLDS | D5h | | R/W |
| DISABLE_FAULT | D7h | | R/W |

Page Command (00h)

The page command data byte of 00h prior to a command call will address the controller specific data and a page data byte of 01h would broadcast to the BCM. The value of the Data Byte corresponds to the pin name trailing number with the exception of 00h and FFh.

| Data Byte | Description |
|-----------|----------------|
| 00h | BCM controller |
| 01h | BCM |

OPERATION Command (01h)

The OPERATION command can be used to turn on and off the connected BCM.

If synchronous startup is required in the system, it is recommended to use the command from host PMBus in order to achieve simultaneous array startup.

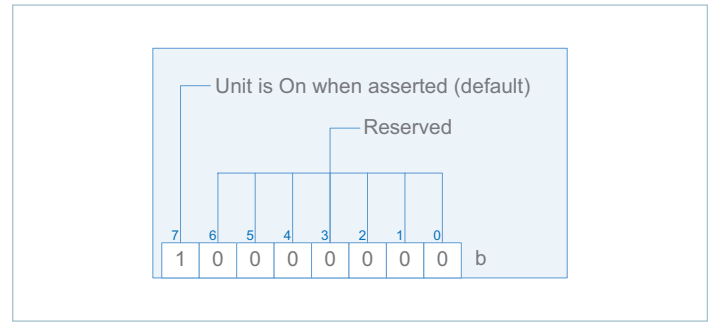

This command accepts only two data values: 00h and 80h. If any other value is sent the command will be rejected and a CML Data error will result.

CLEAR_FAULTS Command (03h)

This command clears all status bits that have been previously set. Persistent or active faults are re-asserted again once cleared. All faults are latched once asserted in the BCM controller. Registered faults will not be cleared when shutting down the BCM powertrain by recycling the BCM high side voltage or sending the OPERATION command.

CAPABILITY Command (19h)

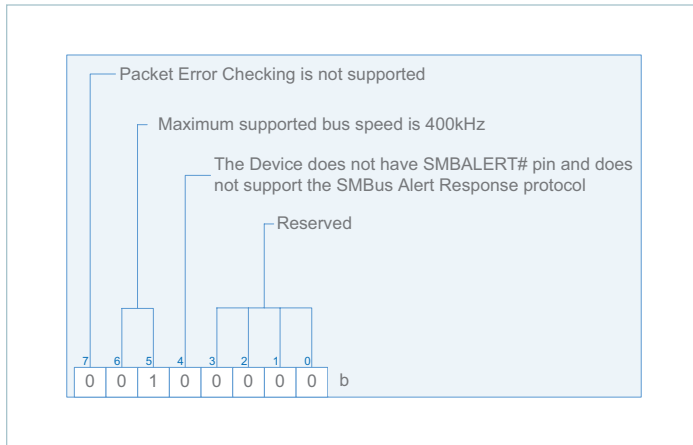

The BCM controller returns a default value of 20h. This value indicates that the PMBus™ frequency supported is up to 400kHz and that both Packet Error Checking (PEC) and SMBALERT# are not supported.

- OT_FAULT_LIMIT Command (4Fh),**
- OT_WARN_LIMIT Command (51h),**
- VIN_OV_FAULT_LIMIT Command (55h),**
- VIN_OV_WARN_LIMIT Command (57h),**
- IIN_OC_FAULT_LIMIT Command (5Bh),**
- IIN_OC_WARN_LIMIT Command (5Dh)**

The values of these registers are set in non-volatile memory and can only be written when the BCM is disabled.

The values of the above mentioned faults and warnings are set by default to 100% of the respective BCM model supervisory limits. However, these limits can be set to a lower value. For example: In order for a limit percentage to be set to 80%, one would send a write command with a (50h) Data Word.

Any values outside the range of (00h – 64h) sent by a host will be rejected, will not override the currently stored value and will set the Unsupported Data bit in STATUS_CML.

The SET_ALL_THRESHOLDS COMMAND (D5h) combines in one block overtemperature fault and warning limits, V_{HI} overvoltage fault and warning limits as well as I_{LO} overcurrent fault and warning limits. A delay prior to a read command of up to 200ms following a write of new value is required.

The VIN_UV_WARN_LIMIT (58h) and VIN_UV_FAULT_LIMIT (59h) are set by the factory and cannot be changed by the host. However, a host can disable the undervoltage setting using the DISABLE_FAULT COMMAND (D7h).

All FAULT_RESPONSE commands are unsupported. The BCM powertrain supervisory limits and powertrain protection will behave as described in the Electrical Specifications. In general, once a fault is detected, the BCM powertrain will shut down and attempt to auto-restart after a predetermined delay.

TON_DELAY Command (60h)

The value of this register word is set in non-volatile memory and can only be written when the BCM is disabled.

The maximum possible delay is 100ms. Default value is set to (00h). The reported value can be interpreted using the following equation.

$$TON_DELAY_{ACTUAL} = t_{REPORTED} \cdot 10^{-3}(s)$$

Staggering startup in an array is possible with the TON_DELAY Command. This delay will be in addition to any startup delay inherent in the BCM module. For example: startup delay from application of V_{HI} is typically 20ms. When TON_DELAY is greater than zero, the set delay will be added to it.

STATUS_BYTE (78h) and STATUS_WORD (79h)

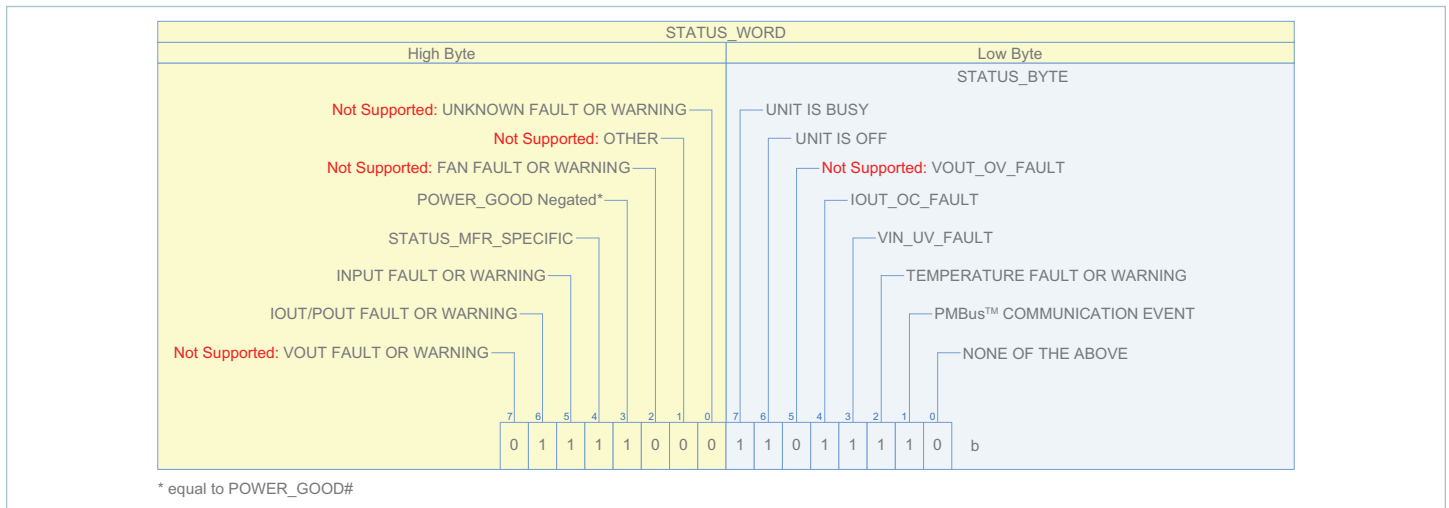

All fault or warning flags, if set, will remain asserted until cleared by the host or once the BCM and VDDb power is removed. This includes undervoltage fault, overvoltage fault, overvoltage warning, overcurrent warning, overtemperature fault, overtemperature warning, undertemperature fault, reverse operation, communication faults and analog controller shutdown fault.

Asserted status bits in all status registers, with the exception of STATUS_WORD and STATUS_BYTE, can be individually cleared. This is done by sending a data byte with one in the bit position corresponding to the intended warning or fault to be cleared. Refer to the PMBus™ Power System Management Protocol Specification – Part II – Revision 1.2 for details.

The POWER_GOOD# bit reflects the state of the device and does not reflect the state of the POWER_GOOD# signal limits. The POWER_GOOD_ON COMMAND (5Eh) and POWER_GOOD_OFF COMMAND (5Fh) are not supported. The POWER_GOOD# bit is set, when the BCM is not in the active state, to indicate that the powertrain is inactive and not switching. The POWER_GOOD# bit is cleared, when the BCM is in the active state, 5ms after the powertrain is activated allowing for soft-start to elapse. POWER_GOOD# and OFF bits cannot be cleared as they always reflect the current state of the device.

The Busy bit can be cleared using CLEAR_ALL Command (03h) or by writing either data value (40h, 80h) to PAGE (00h) using the STATUS_BYTE (78h).

Fault reporting, such as SMBALERT# signal output, and host notification by temporarily acquiring bus master status is not supported.

If the BCM controller is powered through VDDb, it will retain the last telemetry data and this information will be available to the user via a PMBus Status request. This is in agreement with the PMBus standard, which requires that status bits remain set until specifically cleared. Note that in the case where the BCM VHI is lost, the status will always indicate an undervoltage fault, in addition to any other fault that occurred.

NONE OF THE ABOVE bit will be asserted if either the STATUS_MFR_SPECIFIC (80h) or the High Byte of the STATUS_WORD is set.

STATUS_IOUT (7Bh)

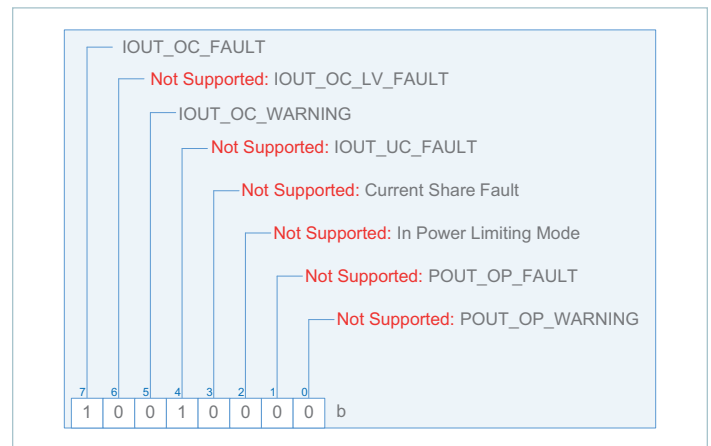

Unsupported bits are indicated above. A one indicates a fault.

STATUS_INPUT (7Ch)

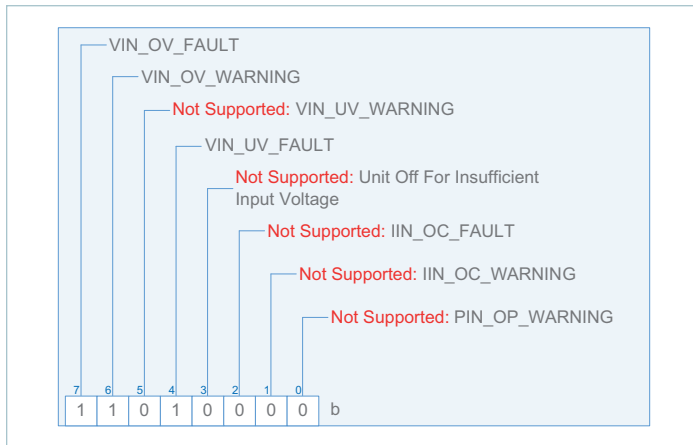

Unsupported bits are indicated above. A one indicates a fault.

STATUS_TEMPERATURE (7Dh)

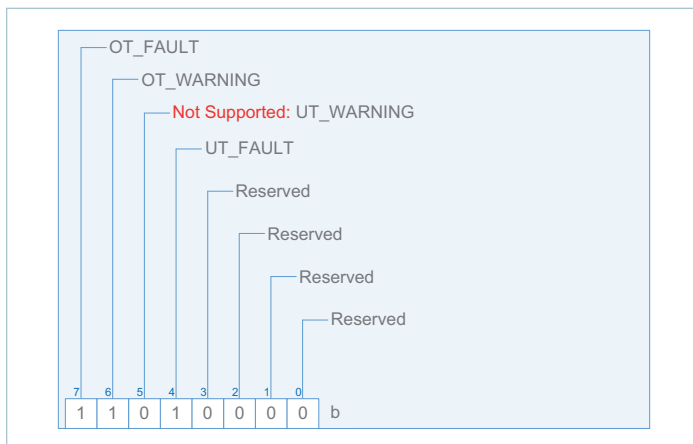

Unsupported bits are indicated above. A one indicates a fault.

STATUS_CML (7Eh)

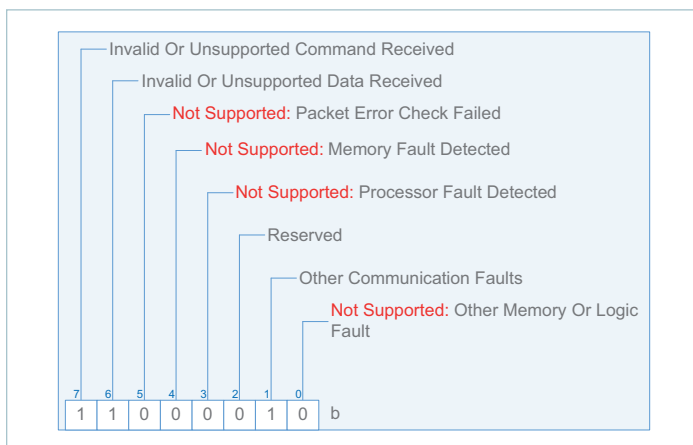

Unsupported bits are indicated above. A one indicates a fault.

The STATUS_CML data byte will be asserted when an unsupported PMBus™ command or data or other communication fault occurs.

STATUS_MFR_SPECIFIC (80h)

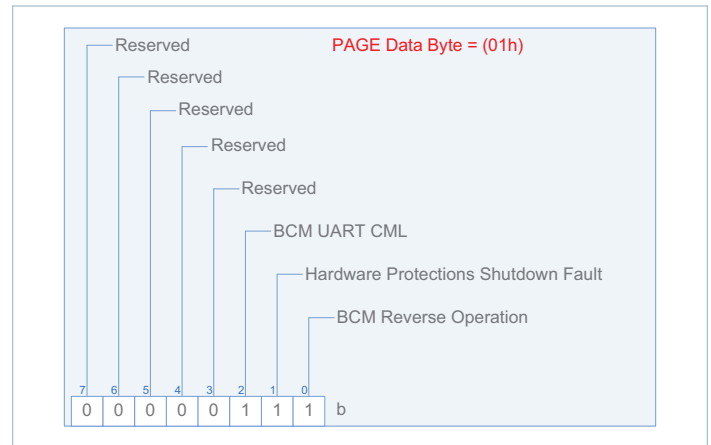

The reverse operation bit, if asserted, indicates that the BCM is processing current in reverse. Reverse current reported value is not supported.

The BCM has hardware protections and supervisory limits. The hardware protections provide an additional layer of protection and have the fastest response time. The Hardware Protections Shutdown Fault, when asserted, indicates that at least one of the powertrain protection faults is triggered. This fault will also be asserted if a disabled fault event occurs after asserting any bit using the DISABLE_FAULTS COMMAND.

The BCM UART is designed to operate with the controller UART. If the BCM UART CML is asserted, it may indicate a hardware or connection issue between both devices.

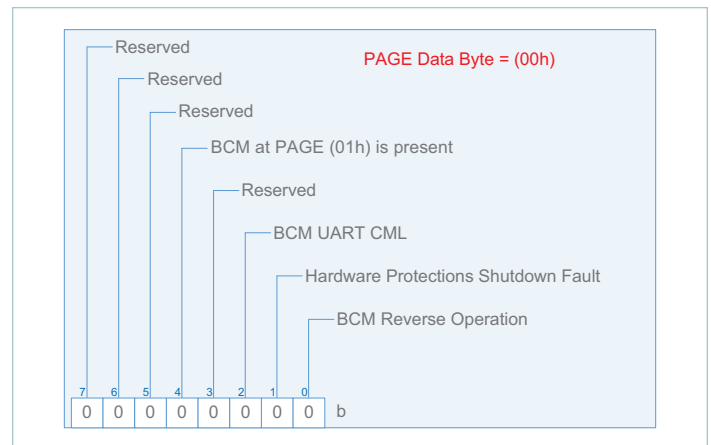

When the PAGE COMMAND (00h) data byte is equal to (00h), the BCM Reverse operation, Analog Controller Shutdown Fault, and BCM UART CML bit will return the result of the active BCM. The BCM UART CML will also be asserted if the active BCM stops responding. The BCM must communicate at least once to the internal controller in order to trigger this FAULT. The BCM UART CML can be cleared using the PAGE (00h) CLEAR_FAULTS (03h) Command.

READ_VIN Command (88h)

If PAGE data byte is equal to (01h), command will return the BCM's HI side voltage in the following format:

$$V_{HI_ACTUAL} = V_{HI_REPORTED} \cdot 10^{-1}(V)$$

READ_IIN Command (89h)

If PAGE data byte is equal to (01h), command will return the BCM's HI side current in the following format:

$$I_{HI_ACTUAL} = I_{HI_REPORTED} \cdot 10^{-2}(A)$$

If PAGE data byte is equal (00h), command will also return the BCM's HI side current.

READ_VOUT Command (8Bh)

If PAGE data byte is equal to (01h), command will return the BCM's LO side voltage in the following format:

$$V_{LO_ACTUAL} = V_{LO_REPORTED} \cdot 10^{-1}(V)$$

READ_IOUT Command (8Ch)

If PAGE data byte is equal to (01h), command will return the BCM's LO side current in the following format:

$$I_{LO_ACTUAL} = I_{LO_REPORTED} \cdot 10^{-2}(A)$$

If PAGE data byte is equal (00h), command will also return the BCM's LO side current.

READ_TEMPERATURE_1 Command (8Dh)

If PAGE data byte is equal to (01h), command will return the BCM's temperature in the following format:

$$T_{ACTUAL} = \pm T_{REPORTED} (^{\circ}C)$$

If PAGE data byte is equal (00h), command will also return the BCM's temperature.

READ_POUT Command (96h)

If PAGE data byte is equal to (01h), command will return the BCM's LO side power in the following format:

$$P_{LO_ACTUAL} = P_{LO_REPORTED} (W)$$

If PAGE data byte is equal to (00h), command will also return the BCM's LO side power.

**MFR_VIN_MIN Command (A0h),
MFR_VIN_MAX Command (A1h),
MFR_VOUT_MIN Command (A4h),
MFR_VOUT_MAX Command (A5h),
MFR_IOUT_MAX Command (A6h),
MFR_POUT_MAX Command (A7h)**

These values are set by the factory and indicate the device HI side/ LO side voltage and LO side current range and LO side power capacity.

If the PAGE data byte is equal to (00h - 01h), commands will report the rated BCM HI side voltage minimum and maximum in Volts, LO side voltage minimum and maximum in Volts, LO side current maximum in Amperes and LO side power maximum in Watts.

READ_K_FACTOR Command (D1h)

If PAGE data byte is equal to (01h), command will return the BCM's K factor in the following format:

$$K_FACTOR_{ACTUAL} = K_FACTOR_{REPORTED} \cdot 2^{-16}(V/V)$$

The K factor is defined in a BCM to represent the ratio of the transformer winding and hence is equal to V_{LO} / V_{HI} .

READ_BCM_ROUT Command (D4h)

If PAGE data byte is equal to (01h) command will return the BCM's LO side resistance in the following format:

$$BCM_R_{LO_ACTUAL} = BCM_R_{LO_REPORTED} \cdot 10^{-5}(\Omega)$$

SET_ALL_THRESHOLDS Command (D5h)

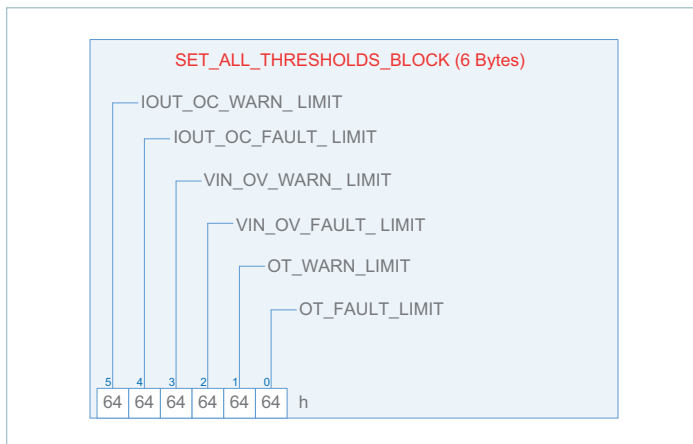

The values of this register block are set in non-volatile memory and can only be written when the BCM is disabled.

This command provides a convenient way to configure all of the limits, or any combination of limits described previously using one command.

V_{HI} overvoltage, overcurrent and overtemperature values are all set to 100% of the specified supervisory limits by default and can only be set to a lower percentage.

To leave a particular threshold unchanged, set the corresponding threshold data byte to a value greater than (64h).

DISABLE_FAULT Command (D7h)

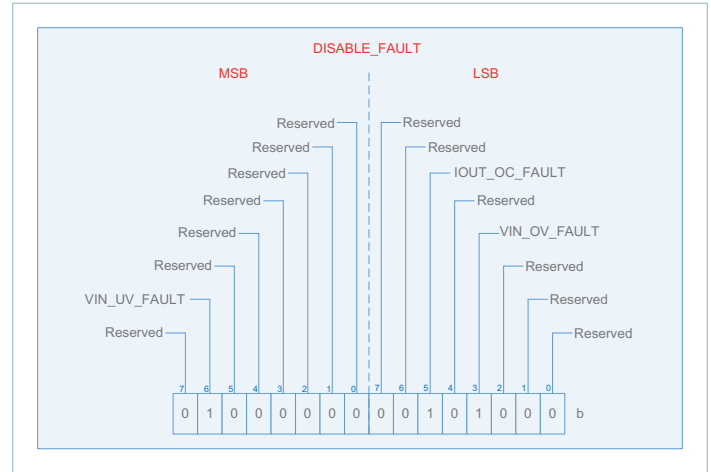

Unsupported bits are indicated above. A one indicates that the supervisory fault associated with the asserted bit is disabled.

The values of this register block are set in non-volatile memory and can only be written when the BCM is disabled.

This command allows the host to disable the supervisory faults and respective statuses. It does not disable the powertrain analog protections or warnings with respect to the set limits in the SET_ALL_THRESHOLDS Command.

The HI side undervoltage can only be disabled to a pre-set low limit as specified in the Monitored Telemetry Functional Reporting Range.

The BCM Controller Implementation vs. PMBus™ Specification Rev 1.2

The BCM controller is an I²C™ compliant, SMBus™ compatible device and PMBus command compliant device. This section denotes some deviation, perceived as differences from the PMBus Part I and Part II specification Rev 1.2.

1. The PMBus interface meets all Part I and II PMBus specification requirements with the following differences to the transport requirement.

| Unmet DC parameter Implementation vs SMBus™ spec | | | | | | |
|--|-----------------------|-----------------|------|---------------|---------------------|-------|
| Symbol | Parameter | PMBus Interface | | SMBus Rev 2.0 | | Units |
| | | Min | Max | Min | Max | |
| V _{IL} [a] | Input Low Voltage | - | 0.99 | - | 0.8 | V |
| V _{IH} [a] | Input High Voltage | 2.31 | - | 2.1 | V _{VDD_IN} | V |
| I _{LEAK_PIN} [b] | Input Leakage per Pin | 10 | 22 | - | ±5 | µA |

[a] V_{VDD_IN} = 3.3V

[b] V_{BUS} = 5V

2. The BCM accepts 38 PMBus command codes. Implemented commands execute functions as described in the PMBus specification.

- Deviations from the PMBus specification:
 - a. Section 15, fault related commands
 - The Limits and Warnings unit is implemented as a percentage (%) range from decimal (0-100) of the factory set limits.

Data Transmission Faults Implementation

This section describes data transmission faults as implemented in the BCM controller.

| Section | Description | Response to Host | | STATUS_BYTE | STATUS_CML | | Notes |
|---------|-----------------------------------|------------------|-----|-------------|-------------|------------------|--|
| | | NAK | FFh | CML | Other Fault | Unsupported Data | |
| 10.8.1 | Corrupted data | | | | | | No response; PEC not supported |
| 10.8.2 | Sending too few bits | | | X | X | | |
| 10.8.3 | Reading too few bits | | | X | X | | |
| 10.8.4 | Host sends or reads too few bytes | | | X | X | | |
| 10.8.5 | Host sends too many bytes | X | | X | | X | |
| 10.8.6 | Reading too many bytes | | X | X | X | | |
| 10.8.7 | Device busy | X | X | | | | Device will ACK own address BUSY bit in STATUS_BYTE even if STATUS_WORD is set |

3. The unsupported PMBus command code response as described in the Fault Management and Reporting:

- Deviations from the PMBus specification:
 - a. PMBus section 10.2.5.3, exceptions
 - The busy bit of the STATUS_BYTE as implemented can be cleared (80h). In order to maintain compatibility with the specification, (40h) can also be used.
 - Manufacturer Implementation of the PMBus Spec
 - a. PMBus section 10.5, setting the response to a detected fault condition
 - All powertrain responses are pre-set and cannot be changed.
 - b. PMBus section 10.6, reporting faults and warnings to the Host.
 - SMBALERT# signal and Direct PMBus Device to Host Communication are not supported. However, the PMBus™ interface will set the corresponding fault status bits and will wait for the host to poll.
 - c. PMBus section 10.7, clearing a shutdown due to a fault
 - There is no RESET pin or EN pin in the BCM. Cycling power to the BCM will not clear a BCM Shutdown. The BCM will clear itself once the fault condition is removed.
 - d. PMBus Section 10.8.1, corrupted data transmission faults:
 - Packet error checking is not supported.

Data Content Faults Implementation

This section describes data content fault as implemented in the BCM controller.

| Section | Description | Response to Host | STATUS_BYTE | STATUS_CML | | | Notes |
|---------|---|------------------|-------------|-------------|---------------------|------------------|--------------------------|
| | | NAK | CML | Other Fault | Unsupported Command | Unsupported Data | |
| 10.9.1 | Improperly set read bit in the address byte | X | X | X | | | |
| 10.9.2 | Unsupported command code | X | X | | X | | |
| 10.9.3 | Invalid or unsupported data | | X | | | X | |
| 10.9.4 | Data out of range | | X | | | X | |
| 10.9.5 | Reserved bits | | | | | | No response; not a fault |

BCM in VIA Package Chassis (Lug) Mount Package Mechanical Drawing

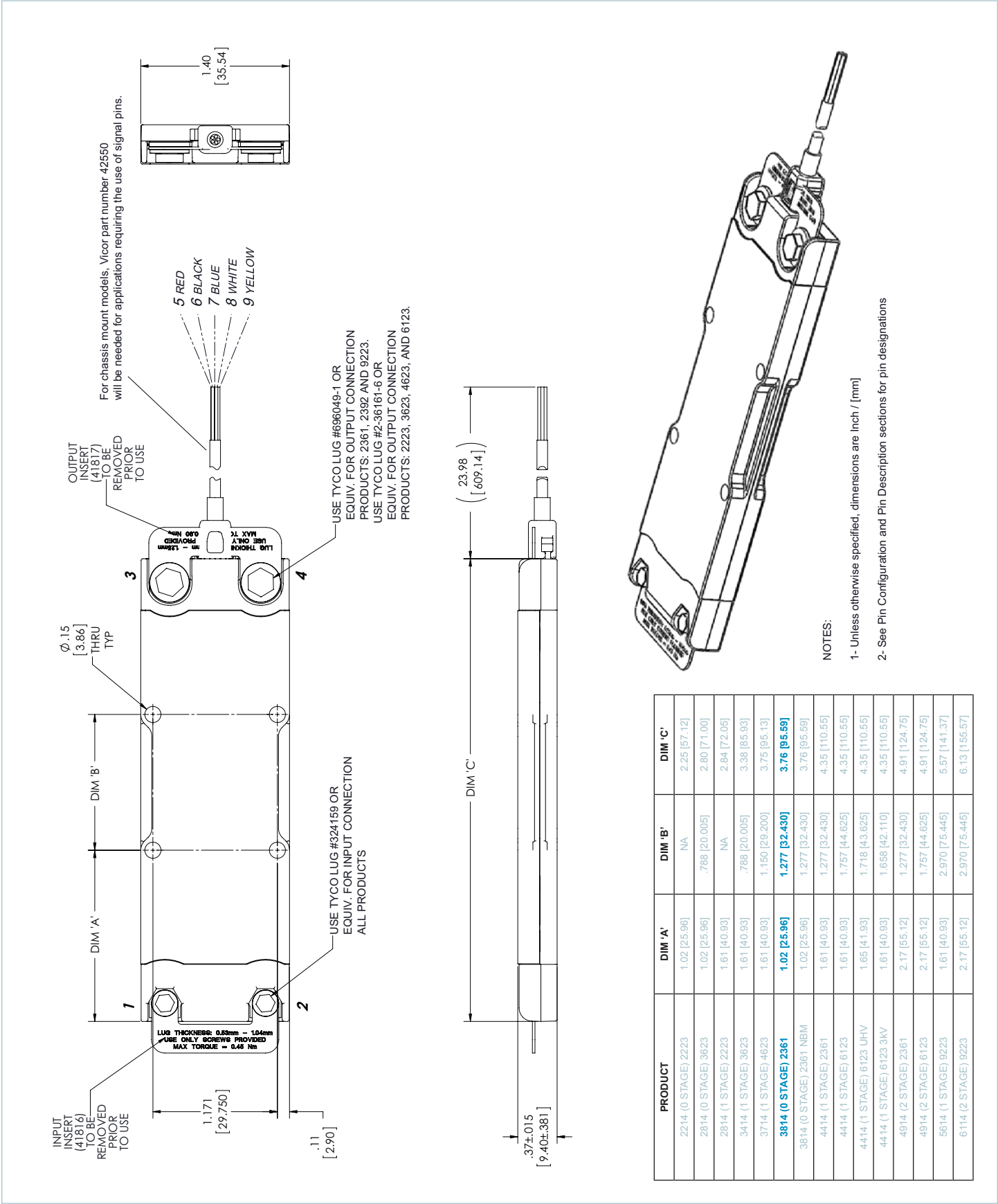

BCM in VIA Package PCB (Board) Mount Package Mechanical Drawing

| PRODUCT | DIM 'A' | DIM 'B' | DIM 'C' | DIM 'D' | DIM 'E' | DIM 'F' | DIM 'G' |
|--------------------------|--------------|----------------|---------------|-----------------|---------------|----------------|-----------------|
| 3814 (0 STAGE) 2361 | 1.02 [25.96] | 1.277 [32.430] | 3.76 [95.59] | 3.368 [85.554] | 3.85 [97.80] | .850 [21.590] | 3.632 [92.243] |
| 3814 (0 STAGE) 2361 NBIM | 1.02 [25.96] | 1.277 [32.430] | 3.76 [95.59] | 3.368 [85.554] | 3.85 [97.80] | .850 [21.590] | 3.632 [92.243] |
| 4414 (1 STAGE) 2361 | 1.61 [40.93] | 1.277 [32.430] | 4.35 [110.55] | 3.957 [100.517] | 4.44 [112.76] | 1.439 [36.554] | 4.221 [107.206] |
| 4914 (2 STAGE) 2361 | 2.17 [55.12] | 1.277 [32.430] | 4.91 [124.75] | 4.517 [114.741] | 5.00 [126.96] | 1.999 [50.777] | 4.781 [121.430] |

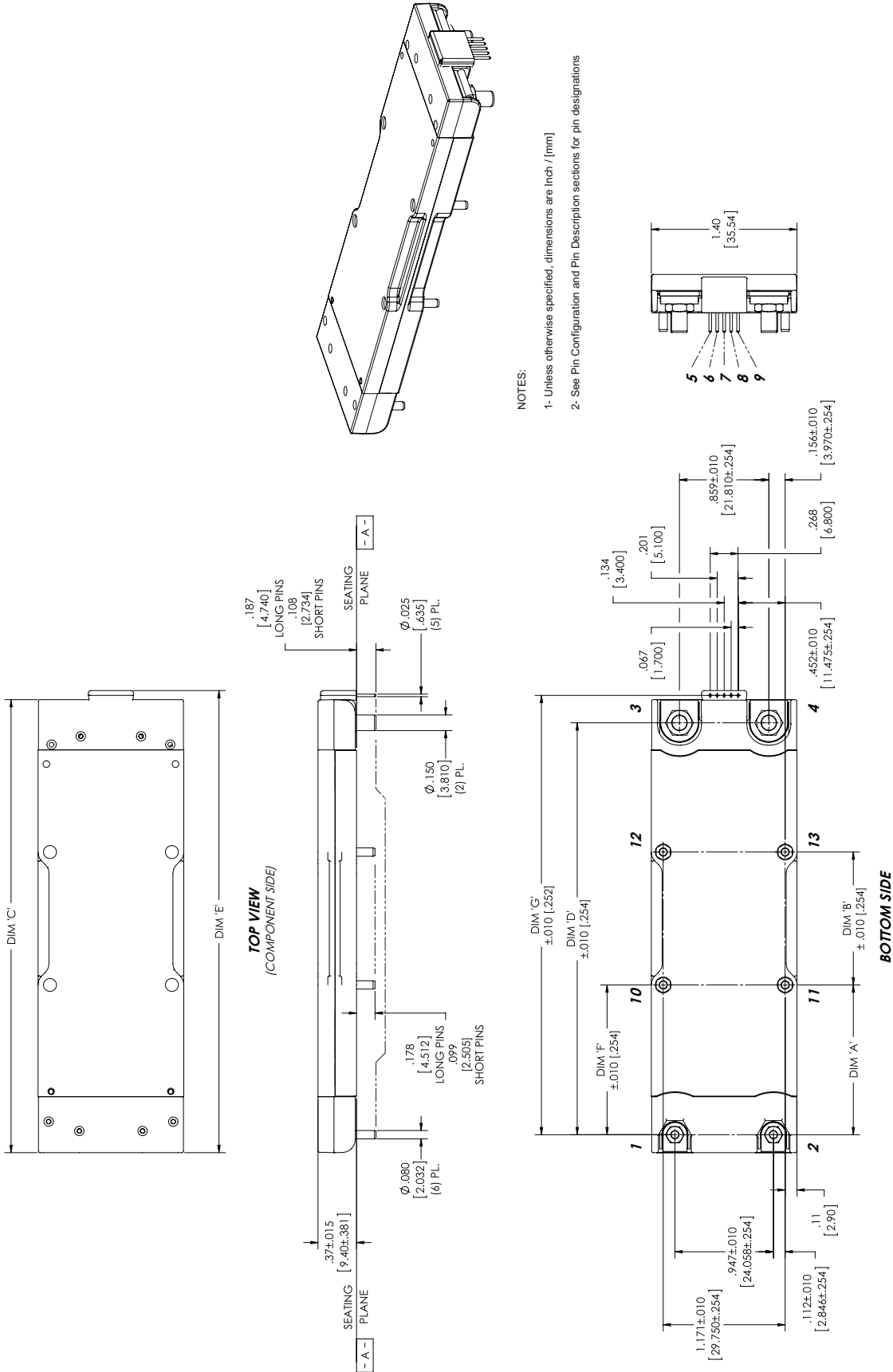

NOTES:
 1- Unless otherwise specified, dimensions are Inch / [mm]
 2- See Pin Configuration and Pin Description sections for pin designations

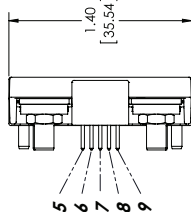

BCM in VIA Package PCB (Board) Mount Package Recommended Hole Pattern

| PRODUCT | DIM 'A' | DIM 'B' | DIM 'C' | DIM 'D' | DIM 'E' | DIM 'F' | DIM 'G' |
|-------------------------|--------------|----------------|---------------|-----------------|---------------|----------------|-----------------|
| 3814 (0 STAGE) 2361 | 1.02 [25.96] | 1.277 [32.430] | 3.76 [95.59] | 3.368 [85.554] | 3.85 [97.80] | .850 [21.590] | 3.632 [92.243] |
| 3814 (0 STAGE) 2361 NEM | 1.02 [25.96] | 1.277 [32.430] | 3.76 [95.59] | 3.368 [85.554] | 3.85 [97.80] | .850 [21.590] | 3.632 [92.243] |
| 4414 (1 STAGE) 2361 | 1.61 [40.93] | 1.277 [32.430] | 4.35 [110.55] | 3.957 [100.517] | 4.44 [112.76] | 1.439 [36.554] | 4.221 [107.206] |
| 4914 (2 STAGE) 2361 | 2.17 [55.12] | 1.277 [32.430] | 4.91 [124.75] | 4.517 [114.741] | 5.00 [126.96] | 1.999 [50.777] | 4.781 [121.430] |

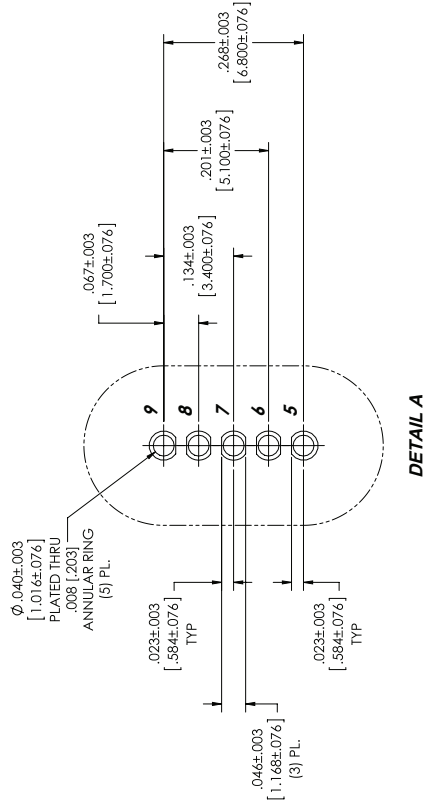
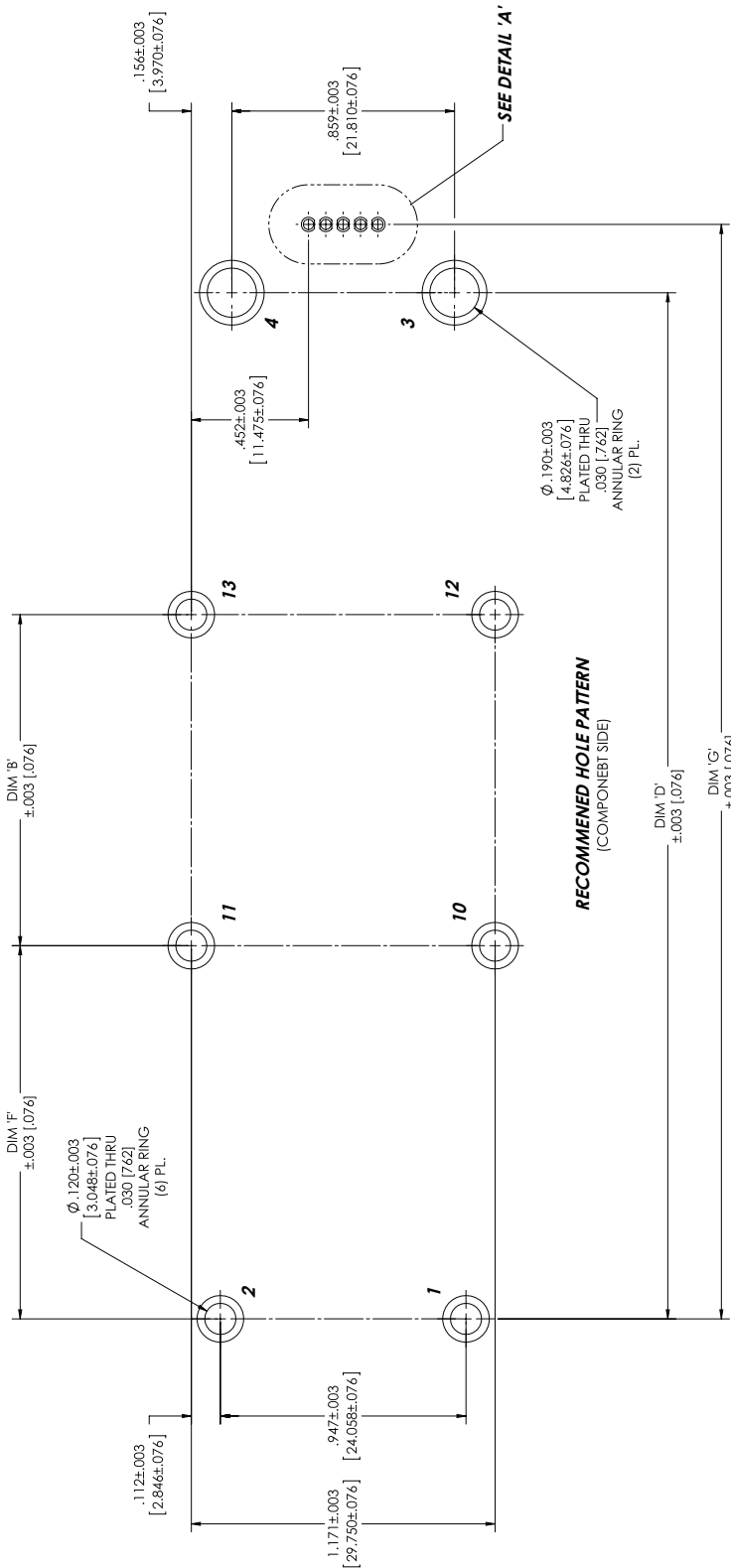

- NOTES:
- 1- Unless otherwise specified, dimensions are inch / [mm]
 - 2- See Pin Configuration and Pin Description sections for pin designations

Revision History

| Revision | Date | Description | Page Number(s) |
|----------|----------|---|----------------------|
| 1.0 | 03/3/16 | Initial release | n/a |
| 1.1 | 05/2/16 | New Power Pin Nomenclature | All |
| 1.2 | 06/17/16 | Notes update | 2, 3, 10 |
| 1.3 | 08/01/16 | Charts format update | 13, 14, 15 |
| 1.4 | 09/26/16 | Value of R correction for READ_BCM_ROUT | 23 |
| 1.5 | 12/13/16 | Content improvements Pin Finish update PMBus™ Supported Commands update | All 17 26 – 37 |
| 1.6 | 03/23/17 | Package drawings update | 37 – 39 |

Vicor's comprehensive line of power solutions includes high density AC-DC and DC-DC modules and accessory components, fully configurable AC-DC and DC-DC power supplies, and complete custom power systems.

Information furnished by Vicor is believed to be accurate and reliable. However, no responsibility is assumed by Vicor for its use. Vicor makes no representations or warranties with respect to the accuracy or completeness of the contents of this publication. Vicor reserves the right to make changes to any products, specifications, and product descriptions at any time without notice. Information published by Vicor has been checked and is believed to be accurate at the time it was printed; however, Vicor assumes no responsibility for inaccuracies. Testing and other quality controls are used to the extent Vicor deems necessary to support Vicor's product warranty. Except where mandated by government requirements, testing of all parameters of each product is not necessarily performed.

Specifications are subject to change without notice.

Vicor's Standard Terms and Conditions and Product Warranty

All sales are subject to Vicor's Standard Terms and Conditions of Sale, and Product Warranty which are available on Vicor's webpage (<http://www.vicorpower.com/termsconditionswarranty>) or upon request.

Life Support Policy

VICOR'S PRODUCTS ARE NOT AUTHORIZED FOR USE AS CRITICAL COMPONENTS IN LIFE SUPPORT DEVICES OR SYSTEMS WITHOUT THE EXPRESS PRIOR WRITTEN APPROVAL OF THE CHIEF EXECUTIVE OFFICER AND GENERAL COUNSEL OF VICOR CORPORATION. As used herein, life support devices or systems are devices which (a) are intended for surgical implant into the body, or (b) support or sustain life and whose failure to perform when properly used in accordance with instructions for use provided in the labeling can be reasonably expected to result in a significant injury to the user. A critical component is any component in a life support device or system whose failure to perform can be reasonably expected to cause the failure of the life support device or system or to affect its safety or effectiveness. Per Vicor Terms and Conditions of Sale, the user of Vicor products and components in life support applications assumes all risks of such use and indemnifies Vicor against all liability and damages.

Intellectual Property Notice

Vicor and its subsidiaries own Intellectual Property (including issued U.S. and Foreign Patents and pending patent applications) relating to the products described in this data sheet. No license, whether express, implied, or arising by estoppel or otherwise, to any intellectual property rights is granted by this document. Interested parties should contact Vicor's Intellectual Property Department.

The products described on this data sheet are protected by the following U.S. Patents Pending.

Vicor Corporation
25 Frontage Road
Andover, MA, USA 01810
Tel: 800-735-6200
Fax: 978-475-6715

email

Customer Service: custserv@vicorpower.com
Technical Support: apps@vicorpower.com