

THIS DRAWING IS UNPUBLISHED. RELEASED FOR PUBLICATION OCT, 1997.
 © COPYRIGHT 1997 By - ALL RIGHTS RESERVED.

LOC	DIST	REVISIONS			
P	LTR	DESCRIPTION	DATE	DWN	APVD
J		A1	REVISED PER ECO-11-005033	29MAR11	RK HMR

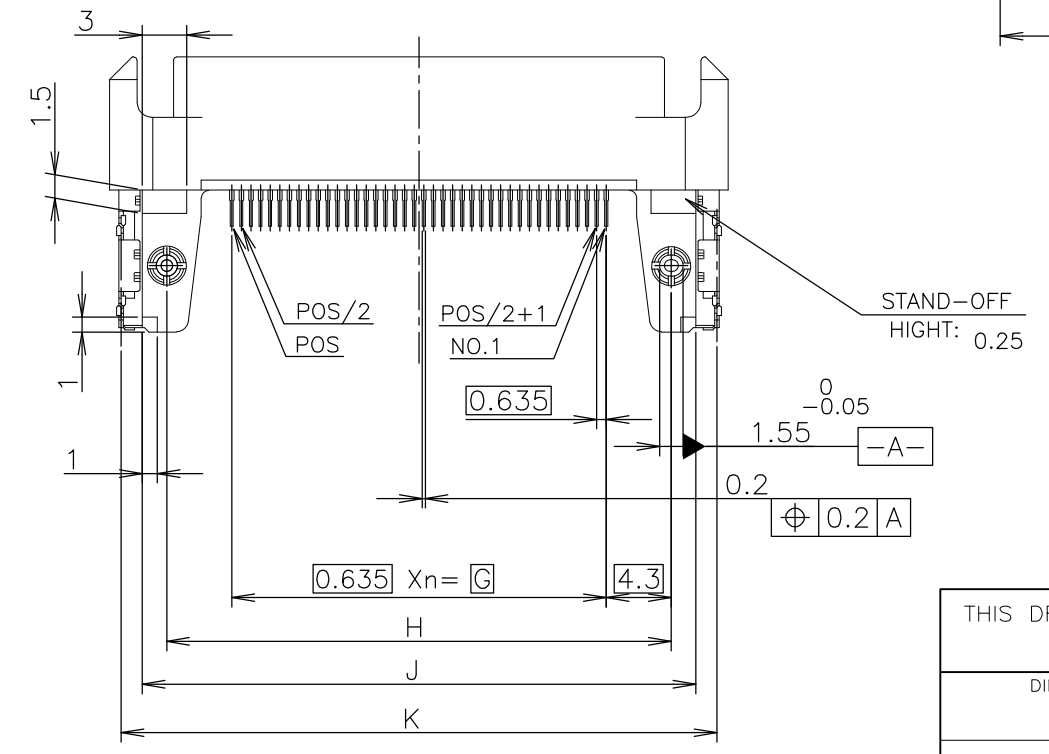
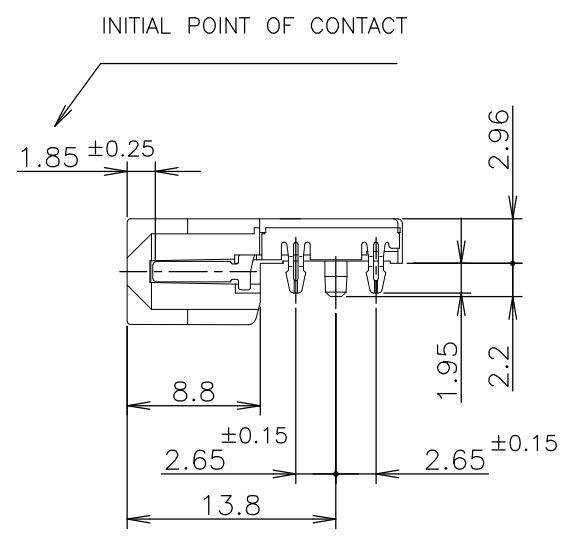
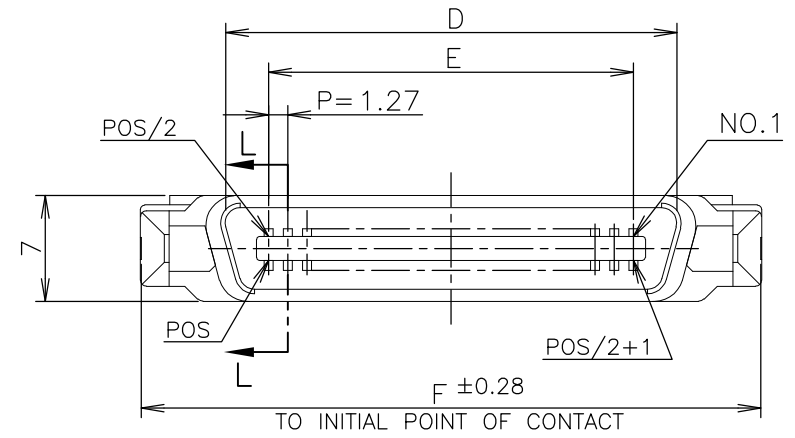
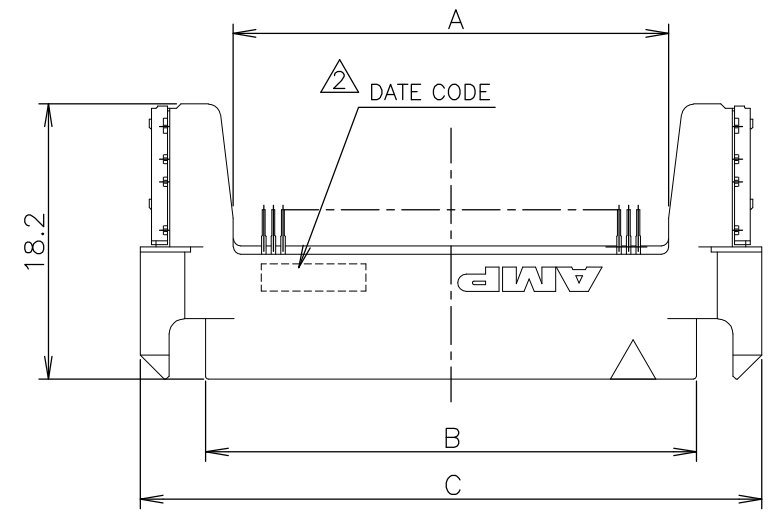

- ① MATERIAL
 - (1) HOUSING: LCP(UL94V-0, BLACK)
 - (2) CONTACT: PHOSPHOR BRONZE
FINISH: CONTACT AREA: Au PL. OVER 0.001 MIN. Ni PL.
SOLDERING AREA: 0.001 MIN. TIN OVER 0.001 MIN. Ni PL.
 - (3) G-CONT. WITH RETENTION-LEG: BRASS
FINISH: 0.001 MIN. TIN PL. OVER 0.001 MIN. Ni PL.
- ② INDICATE DATE CODE.
- ③ THIS DIM. IS 1.6±0.08 WHEN THE CONTACT PUSH TO HOUSING.

6123283-9	0.0002	80	79	54.2	57.87	66.5	55.27	49.53	66.4	50.165	58.765	62.0	64.7
5-6123283-5	0.00076	40	39	28.8	32.47	41.1	29.87	24.13	41.0	24.765	33.365	36.6	39.3
6123283-5	0.0002	40	39	28.8	32.47	41.1	29.87	24.13	41.0	24.765	33.365	36.6	39.3
PART NO.	Au PL.	POS	n	A	B	C	D	E	F	G	H	J	K

GENERAL TOLERANCE
 10 ≥ * : ± 0.2
 30 ≥ * > 10 : ± 0.25
 100 ≥ * > 30 : ± 0.3
 ANGLES : ± 3°

THIS DRAWING IS A CONTROLLED DOCUMENT.

DIMENSIONS: mm

TOLERANCES UNLESS OTHERWISE SPECIFIED:

0 PLC	±
1 PLC	±
2 PLC	±
3 PLC	±
4 PLC	±
ANGLES	±
FINISH	①

MATERIAL ①

WENKE HE 9MAR05
 STEVEN YAO 9MAR05
 I. ENOMOTO 9MAR05

STE TE Connectivity

PLUG ASSY SMT TYPE, CHAMP.050 I
 BLINDMATE WITH G-CONT. P.C.B. t=0.8mm

SIZE: A3 CAGE CODE: 00779 DRAWING NO: C-6123283

CUSTOMER DRAWING SCALE: NTS SHEET: 1 OF 2 REV: A1

THIS DRAWING IS UNPUBLISHED. RELEASED FOR PUBLICATION OCT, 1997.
 © COPYRIGHT 1997 By - ALL RIGHTS RESERVED.

LOC	DIST	REVISIONS			
P	LTR	DESCRIPTION	DATE	DWN	APVD
		SEE SHEET 1	-	-	-

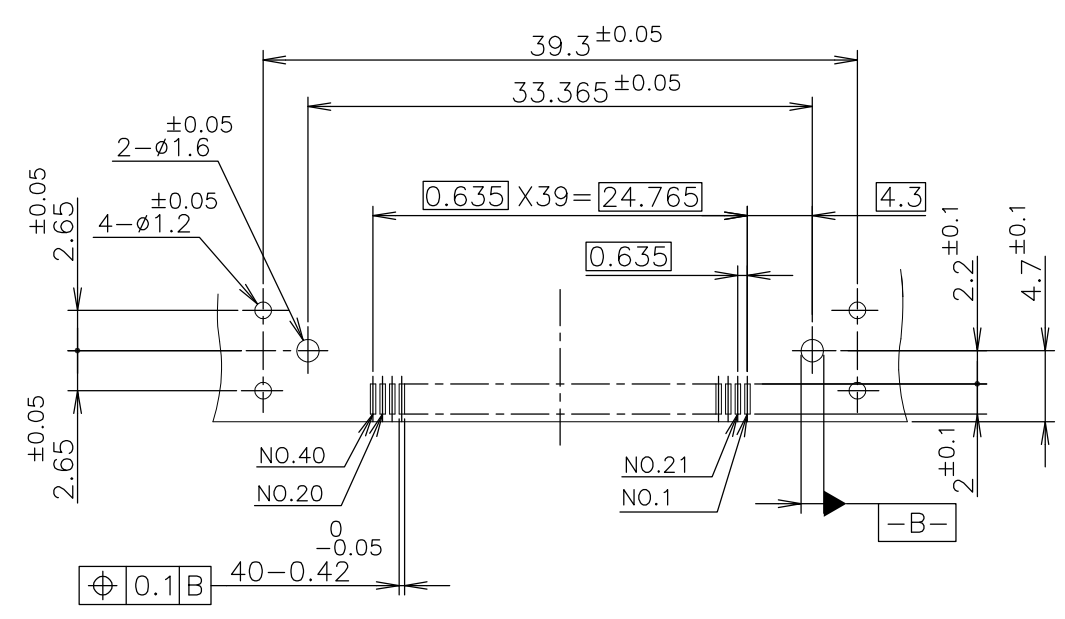
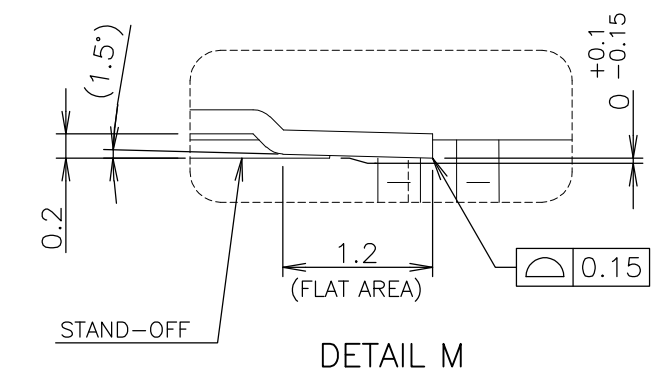
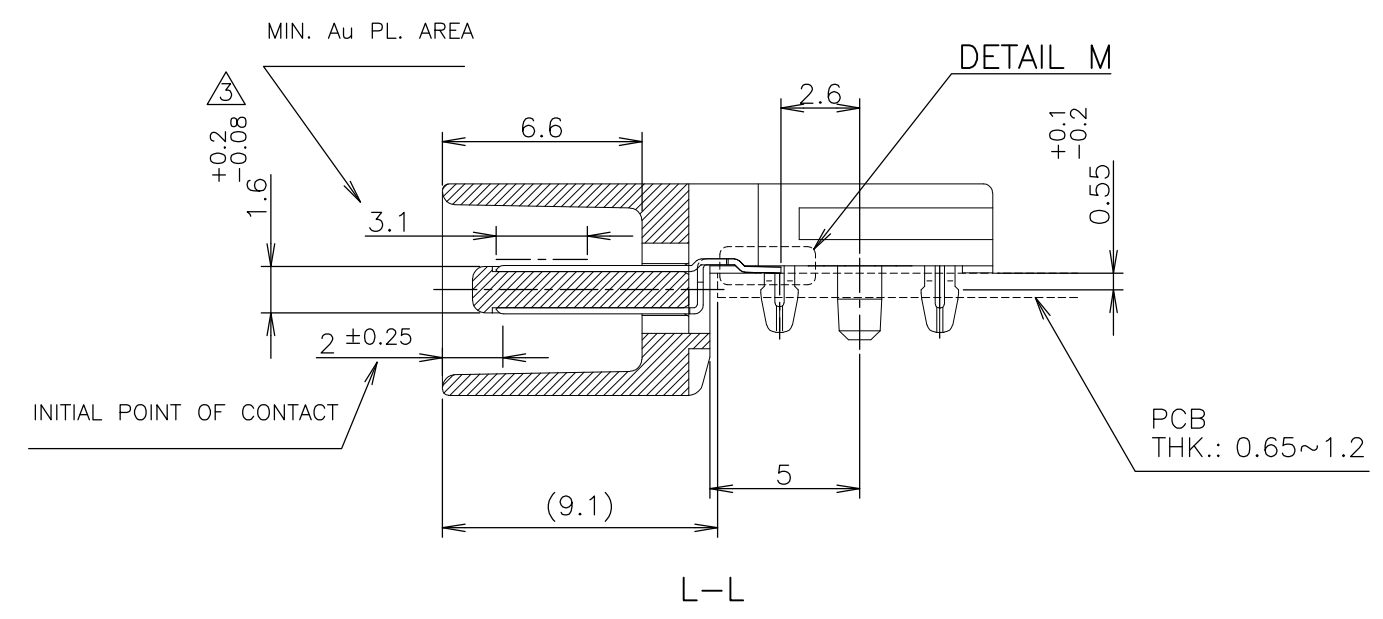

40P

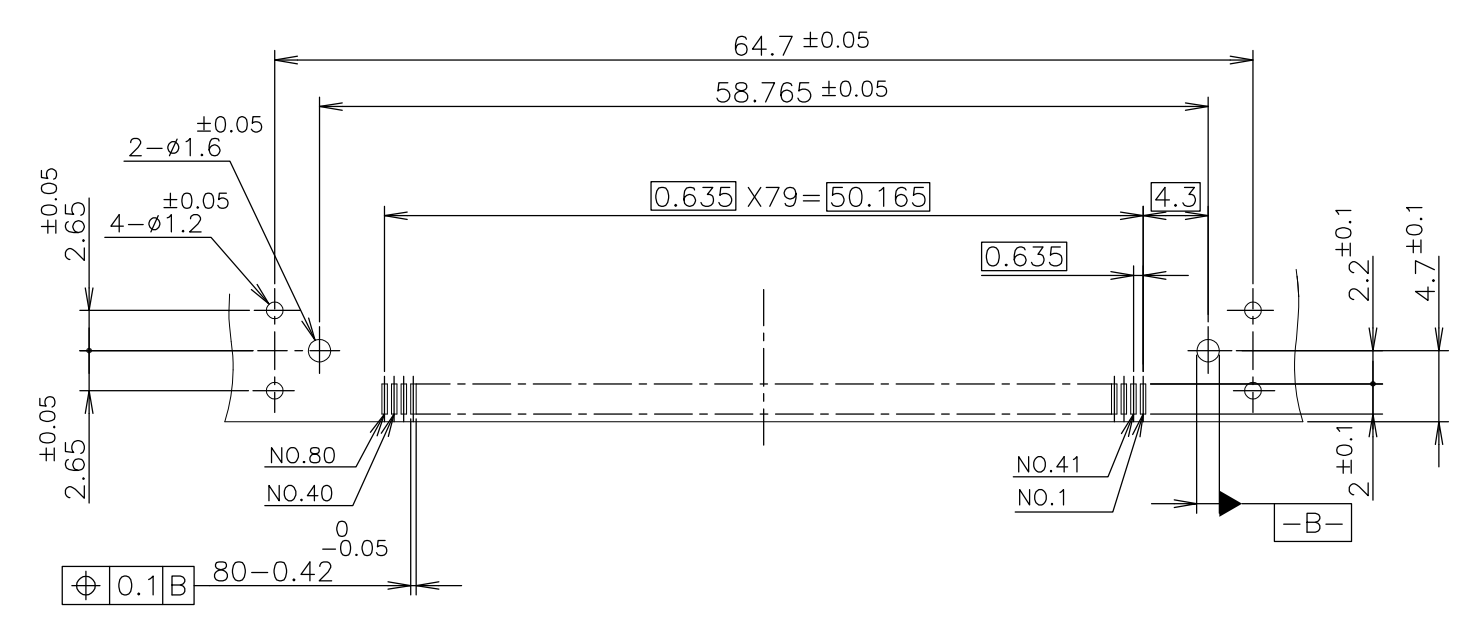

80P

RECOMMENDED PCB LAYOUT

THIS DRAWING IS A CONTROLLED DOCUMENT.		DWN	TE Connectivity NAME PLUG ASSY SMT TYPE, CHAMP.050 I BLINDMATE WITH G-CONT. P.C.B. t=0.8mm			
DIMENSIONS: mm		CHK				
TOLERANCES UNLESS OTHERWISE SPECIFIED:		APVD				
0 PLC ± 1 PLC ± 2 PLC ± 3 PLC ± 4 PLC ± ANGLES ± FINISH ±		PRODUCT SPEC				
GENERAL TOLERANCE		APPLICATION SPEC	SIZE	CAGE CODE	DRAWING NO	RESTRICTED TO
$10 \geq * : \pm 0.2$ $30 \geq * > 10 : \pm 0.25$ $100 \geq * > 30 : \pm 0.3$ ANGLES: $\pm 3^\circ$		WEIGHT	A3	00779	G-6123283	
MATERIAL		CUSTOMER DRAWING	SCALE	SHEET	REV	
			NTS	2 OF 2	A1	