

PROPER USE GUIDELINES

Cumulative Trauma Disorders can result from the prolonged use of manually powered hand tools. These hand tools are intended for occasional use and low volume applications. A wide selection of powered application equipment for extended-use, production operations is available.

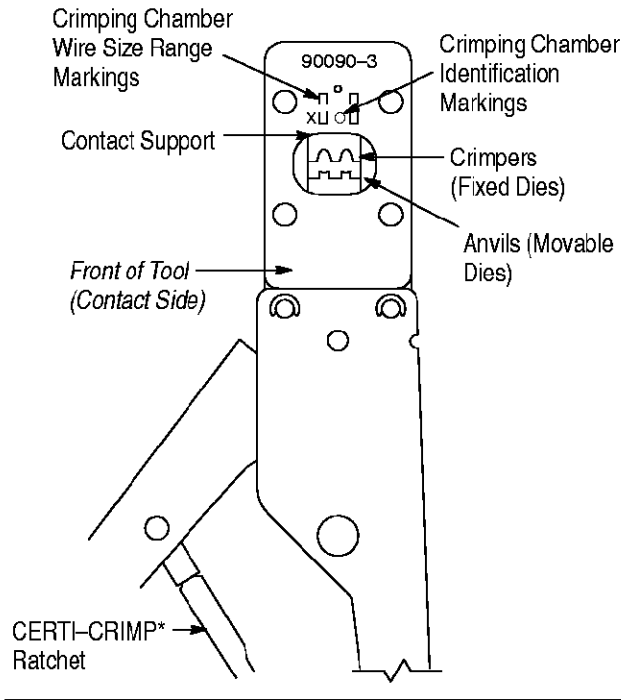

Figure 1

1. INTRODUCTION

AMP* Hand Crimping Tools 90090-3 (shown in Figure 1) and 90174-2 are designed to crimp AMP-TAB* contacts listed in Figure 2 onto stranded or solid wire sizes 26 through 18 AWG with an insulation diameter range of 0.89 through 1.88 mm [.035 through .074 in.]. Read these instructions thoroughly before using the tool.

NOTE

Dimensions in this instruction sheet are in millimeters [with inches in brackets]. Figures are not drawn to scale.

Reasons for reissue of this instruction sheet are provided in Section 6, REVISION SUMMARY.

2. DESCRIPTION

The tool features two fixed dies (crimpers), two movable dies (anvils), contact support, locator, insulation stop, ejector, and CERTI-CRIMP ratchet. When mated, the dies forms two crimping chambers. The FRONT of the tool (contact side), into which the contact is inserted, has the tool number marked on it. The BACK of the tool (wire side), into which the wire

is inserted, has the applicable wire size range and identification (X or O) marked above each crimping chamber.

The contact support prevents the contact from bending during the crimping operation. The insulation stop aids in positioning the wire in the contact. The locator aids in positioning the contact between the dies before crimping. The ejector pulls the insulation stop down and ejects the crimped contact.

The CERTI-CRIMP ratchet assures full crimping of the contact. Once engaged, the ratchet will not release until the handles have been FULLY closed.

CAUTION

The dies bottom before the ratchet releases. This feature ensures maximum electrical and tensile performance of the crimp. Do NOT re-adjust the ratchet.

3. CRIMPING PROCEDURE

Refer to Figure 2, and select wire of specified size and insulation diameter. Strip the wire to the length indicated—do NOT cut or nick the wire strands.

Typical AMP-TAB Contact

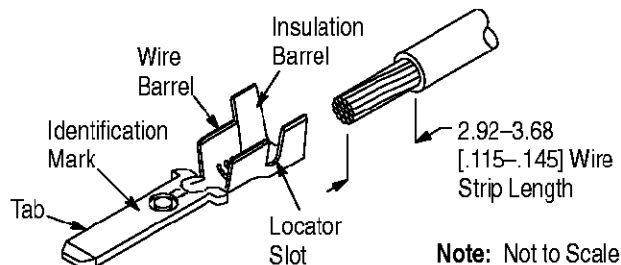

WIRE		CONTACT	TOOL	MARKING (Crimping Chamber and Contact)
SIZE RANGE (AWG)	INSUL DIA RANGE			
26-22	0.89-1.37 [.035-.054]	66168-[]	90090-3 or 90174-2	O
22-20	1.17-1.57 [.046-.062]	66169-[]	90174-2	X
26-18	1.37-1.88 [.054-.074]		90090-3	

Figure 2

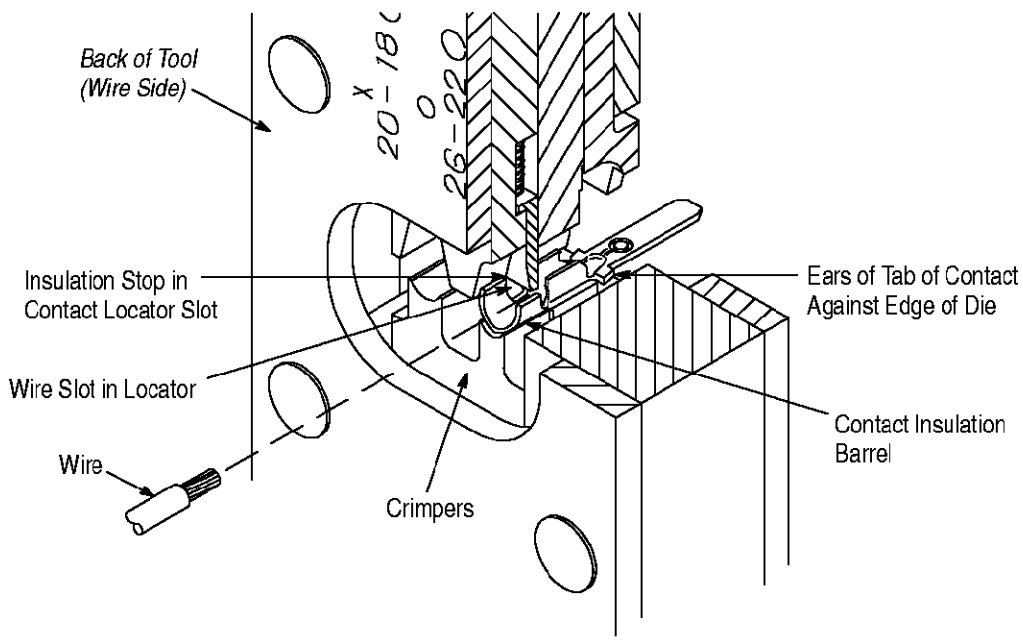
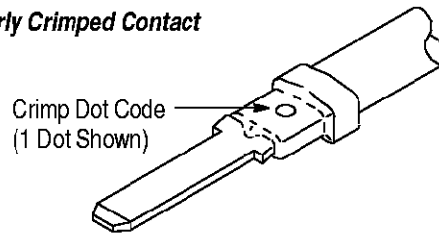

Figure 3

Select the applicable contact and compatible tool. Make sure that the identification marking on the contact matches the identification marking on the tool crimping chamber. Proceed as follows:

1. Hold tool so BACK side (wire side) faces you.
2. Ensure that the tool ratchet is released by squeezing tool handles and allowing them to open FULLY.
3. Insert contact, insulation barrel first, into the appropriate crimping chamber from the FRONT of tool. Position the contact between the crimpers so that the insulation stop enters the contact locator slot. Make sure that the ears of the tab is against the edge of the die. See Figure 3.
4. Holding the contact in position, squeeze the tool handles together until anvil starts entry into the crimper. Do NOT deform contact insulation barrel or wire barrel.
5. Insert a properly stripped wire through the wire slot in the locator and into the contact wire barrel until the wire insulation butts against the insulation stop.
6. Holding the wire in place, squeeze the tool handles together until the ratchet releases. Allow tool handles to open FULLY.
7. Remove crimped contact from tool, and inspect the crimp to make sure that the proper crimp dot code appears on the bottom of the wire barrel. See Figure 4.

Properly Crimped Contact



CONTACT	MARKING (Crimping Chamber and Contact)	CRIMP DOT CODE
66168-[]	O	1
66169-[]	X	2

Figure 4

4. MAINTENANCE AND INSPECTION

The tool is inspected before shipment. It is recommended that the tool be inspected immediately upon arrival at your facility to ensure that the tool was not damaged during shipment.

4.1. Daily Maintenance

Remove all foreign particles with a clean, soft brush, or a clean, soft, lint-free cloth. Make sure the proper retaining pins are in place, and secured with the proper retaining rings. If foreign matter cannot be removed easily, or if the proper replacement parts are not available, refer to Section 5, REPLACEMENT AND REPAIR, for information on obtaining further evaluation and repair.

Make certain all pivot points and bearing surfaces are protected with a THIN coat of any good SAE 20 motor oil. Do NOT oil excessively. When tool is not in use, keep the handles closed to prevent objects from becoming lodged between the dies, and store the tool in a clean, dry area.

4.2. Periodic Inspection

Regular inspections should be performed by quality control personnel. A record of scheduled inspections should remain with the tool and/or be supplied to personnel responsible for the tool. Though recommendations call for at least one inspection a month, the inspection frequency should be based on the amount of use, ambient working conditions, operator training and skill, and established company standards. These inspections should be performed in the following sequence:

A. Visual Inspection

1. Remove all lubrication and accumulated film by immersing the tool (handles partially closed) in a suitable commercial degreaser that will not affect paint or plastic material.
 2. Make certain all retaining pins are in place and secured with retaining rings. If replacements are necessary, refer to parts listed in Section 5.
- CAUTION** Do NOT remove the retaining pins as permanent damage to the tool may result.
3. Close the tool handles until the ratchet releases, then allow the tool handles to open freely. If handles do not open quickly and fully, the spring is defective and must be replaced (refer to Section 5, REPLACEMENT AND REPAIR).
 4. Inspect the head assembly, with special emphasis on checking for worn, cracked, or broken dies. If damage to any part of the head assembly is evident, refer to Section 5 for information on obtaining customer repair service.

B. Crimp Height Inspection

This inspection requires the use of a micrometer with a modified anvil as shown in Figure 5. It is recommended using the modified micrometer (Crimp Height Comparator RS-1019-5LP) which can be purchased from:

Shearer Industrial Supply Co. VALCO
 20 North Penn Street 1410 Stonewood Drive
 York, PA 17401-1014 or Bethlehem, PA 18017-3527

Proceed as follows:

1. Select a contact and *maximum* size wire for the crimping chamber.

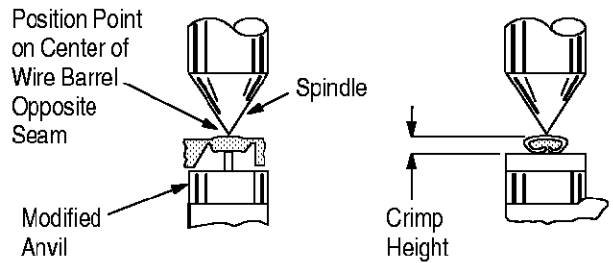

TOOL	WIRE SIZE (AWG) (Max)	CRIMP HEIGHT DIMENSION (±0.05 [±.002])
90090-3	22	0.94 [.037]
	18	1.35 [.053]
90174-2	22	0.94 [.037]
	20	1.24 [.049]

Figure 5

2. Refer to Section 3, CRIMPING PROCEDURE, and crimp the contact accordingly.
3. Using a crimp height comparator, measure wire barrel crimp height as shown in Figure 5. If the crimp height conforms to that shown, the tool is considered dimensionally correct. If not, refer to Section 5 for information on obtaining evaluation and repair.

For additional information concerning the use of the crimp height comparator, refer to 408-7424.

C. CERTI-CRIMP Ratchet Inspection

Obtain a 0.0254 [.001] shim that is suitable for checking the clearance between the bottoming surfaces of the dies. Proceed as follows:

1. Select a contact and *maximum* wire size for the tool.
2. Position the contact and wire between the dies, according to Section 3, CRIMPING PROCEDURE. Holding the wire in place, squeeze the tool handles together until the ratchet releases. Hold the tool handles in this position, maintaining just enough pressure to keep the dies closed.
3. Check the clearance between the bottoming surfaces of the crimping dies. If the clearance is 0.0254 [.001] or less, the ratchet is satisfactory. If clearance exceeds 0.0254 [.001] the ratchet is out of adjustment and must be repaired (see Section 5, REPLACEMENT AND REPAIR).

If the tool conforms to these inspection procedures, lubricate it with a THIN coat of any good SAE 20 motor oil and return it to service.

5. REPLACEMENT AND REPAIR

Customer-replaceable parts are listed in Figure 6. A complete inventory should be stocked and controlled to prevent lost time when replacement of parts is necessary. Parts other than those listed should be replaced by Tyco to ensure quality and reliability. Order replacement parts through your representative, or call 1-800-526-5142, or send a facsimile of your purchase order to 717-986-7605, or write to:

CUSTOMER SERVICE (038-035)
 TYCO ELECTRONICS CORPORATION
 PO BOX 3608
 HARRISBURG PA 17105-3608

For customer repair service, please contact a representative at 1-800-526-5136.

6. REVISION SUMMARY

Revisions to this instruction sheet per EC 0990-1454-99 include:

- Updated document to corporate requirements
- Changed title of document
- Added company reference and changed VALCO address in Paragraph 4.2, B
- Modified Step 3 in Section 3
- Removed reference to Tool 90174-1 from Figure 2
- Removed replacement parts kit, and changed quantity per kit to quantity per tool in Figure 6
- Modified Figures 3 and 6
- Replaced customer repair address with phone number

CAUTION: Do NOT remove retaining pins as permanent damage to the tool may result.

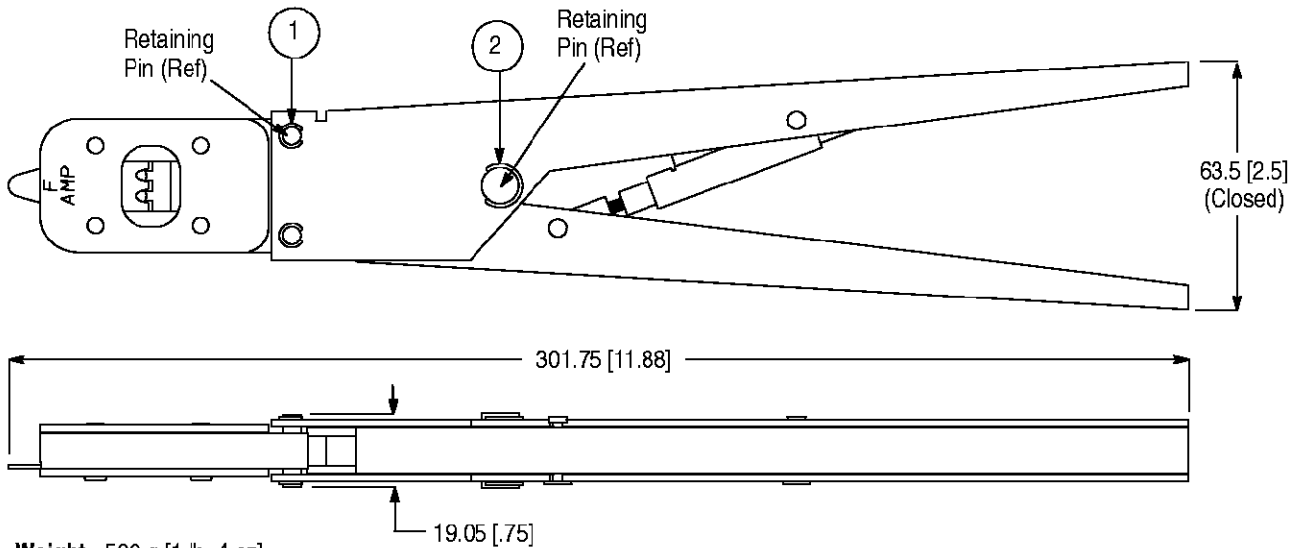

Weight: 509 g [1 lb, 4 oz]

REPLACEMENT PARTS

ITEM	PART NUMBER	DESCRIPTION	QTY PER TOOL
1	21045-3	RING, Retaining	4
2	21045-9	RING, Retaining	2

Figure 6