

Aug.1.2018 Copyright 2018 HIROSE ELECTRIC CO., LTD. All Rights Reserved.
 In case that the application demands a high level of reliability, such as automotive,
 please contact a company representative for further information.

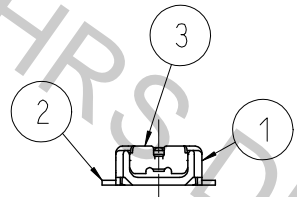

ENGAGEMENT FIGURE (50:1)

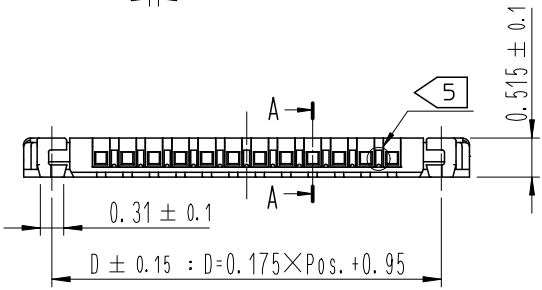
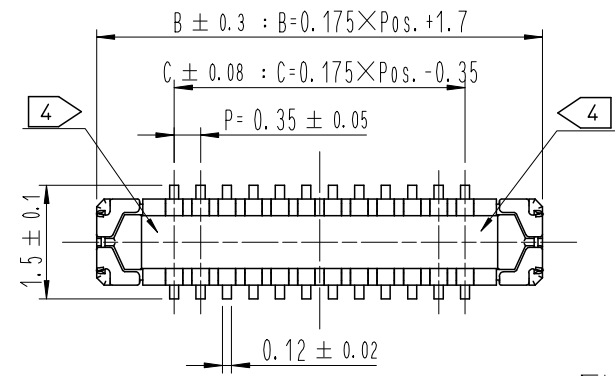
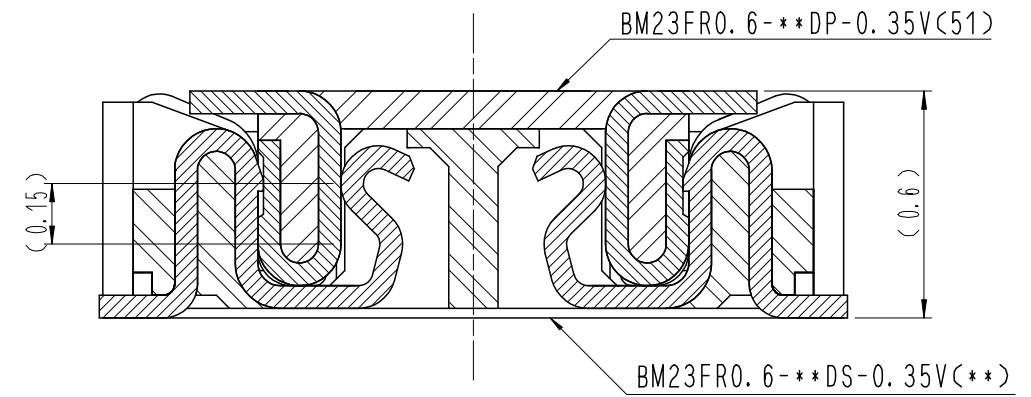

DRAWING FOR REFERENCE
 This is subject to change without notice

A-A (50:1)

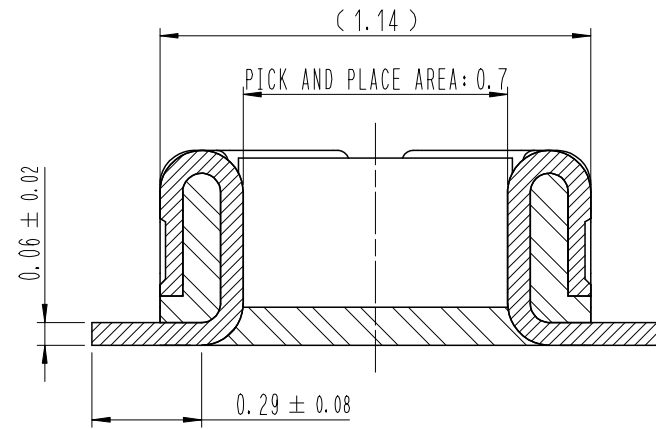

- NOTE
- 1. ALL LEAD CO-PLANARITY SHALL BE 0.08mm MAX.
 - 2. CONTACT PLATING SPECIFICATIONS.
 CONTACT AREA : GOLD 0.05 μm MIN.
 SMT LEAD : GOLD 0.05 μm MIN.
 UNDER PLATING : NICKEL 1 μm MIN.
 (SURFACE : SEALING)
 - 3. METAL FITTING PLATING SPECIFICATIONS.
 SMT LEAD : GOLD 0.05 μm MIN.
 UNDERPLATING : NICKEL 1 μm MIN.
 (SURFACE : SEALING)
 - 4. CAV No. IS INDICATED IN APPROX POSITION SHOWN.
 - 5. A PART OF THE WALL COULD BE NOTCHED.

COUNT	DESCRIPTION OF REVISIONS	B	Y	CHKD	DATE	COUNT	DESCRIPTION OF REVISIONS	B	Y	CHKD	DATE
3	RE-6-0649	J.S.H	J.H.W		16. 05. 04						
3	RE-6-0774	J.S.H	J.H.W		16. 11. 07						

△ PART No.	CODE No.	POS.	B	C	D
BM23FR0.6-6DP-0.35V(51)	-	6	2.75	0.70	2.00
BM23FR0.6-8DP-0.35V(51)	-	8	3.10	1.05	2.35
BM23FR0.6-10DP-0.35V(51)	-	10	3.45	1.40	2.70
BM23FR0.6-12DP-0.35V(51)	-	12	3.80	1.75	3.05
BM23FR0.6-16DP-0.35V(51)	-	16	4.50	2.45	3.75
BM23FR0.6-20DP-0.35V(51)	-	20	5.20	3.15	4.45
BM23FR0.6-24DP-0.35V(51)	-	24	5.90	3.85	5.15
BM23FR0.6-30DP-0.35V(51)	-	30	6.95	4.90	6.20
BM23FR0.6-34DP-0.35V(51)	-	34	7.65	5.60	6.90
BM23FR0.6-40DP-0.35V(51)	-	40	8.70	6.65	7.95
BM23FR0.6-50DP-0.35V(51)	-	50	10.45	8.40	9.70

NO.	MATERIAL	FINISH, REMARKS	NO.	MATERIAL	FINISH, REMARKS
4	PS	CLEAR (EMBOSSED CARRIER TAPE)			
3	PHOSPHOR BRONZE	3	7	PS	CLEAR (REINFORCEMENT COLLAR)
2	PHOSPHOR BRONZE	2	6	PS	BLACK (PLASTIC REEL)
1	LCP	UL94 V-0, BLACK	5	POLYESTER	CLEAR (COVER TAPE)

REMARKS	DRAWN	DESIGNED	CHECKED	APPROVED	RELEASED
	D. W. KIM	D. W. KIM	H. W. JO	T. S. KANG	16.11.07
	14.11.06	14.11.06	14.11.06	14.11.06	

CODE NO. (OLD)	DRAWING NO.	PART NO.	CODE NO.
	EDC3-*****	BM23FR0.6-**-DP-0.35V(51)	CL 66**-*****-***

SCALE 10:1
 UNITS mm
HRS HIROSE KOREA CO., LTD.

Aug.1.2018 Copyright 2018 HIROSE ELECTRIC CO., LTD. All Rights Reserved.
 In case that the application demands a high level of reliability, such as automotive,
 please contact a company representative for further information.

7 RECOMMENDED PCB LAYOUT

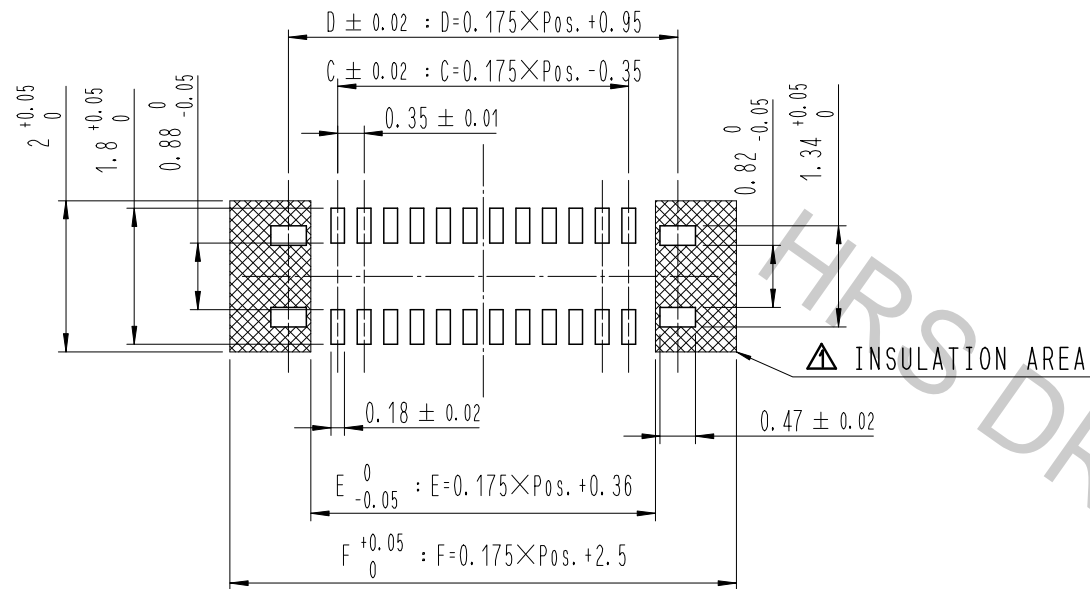

RECOMMENDED METAL MASK DIMENSIONS

METAL MASK THICKNESS : 100 μm

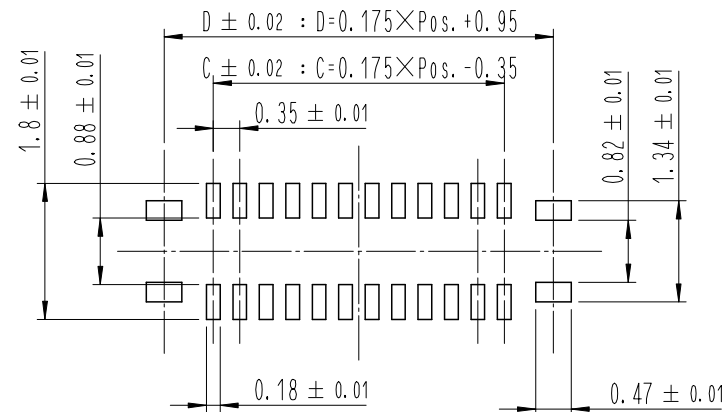

△ POS.	C	D	E	F
6	0.70	2.00	1.41	3.55
8	1.05	2.35	1.76	3.90
10	1.40	2.70	2.11	4.25
12	1.75	3.05	2.46	4.60
16	2.45	3.75	3.16	5.30
20	3.15	4.45	3.86	6.00
24	3.85	5.15	4.56	6.70
30	4.90	6.20	5.61	7.75
34	5.60	6.90	6.31	8.45
40	6.65	7.95	7.36	9.50
50	8.40	9.70	9.11	11.25

6 RECOMMENDED REFLOW TEMPERATURE PROFILE USING LEAD-FREE SOLDER PASTE.

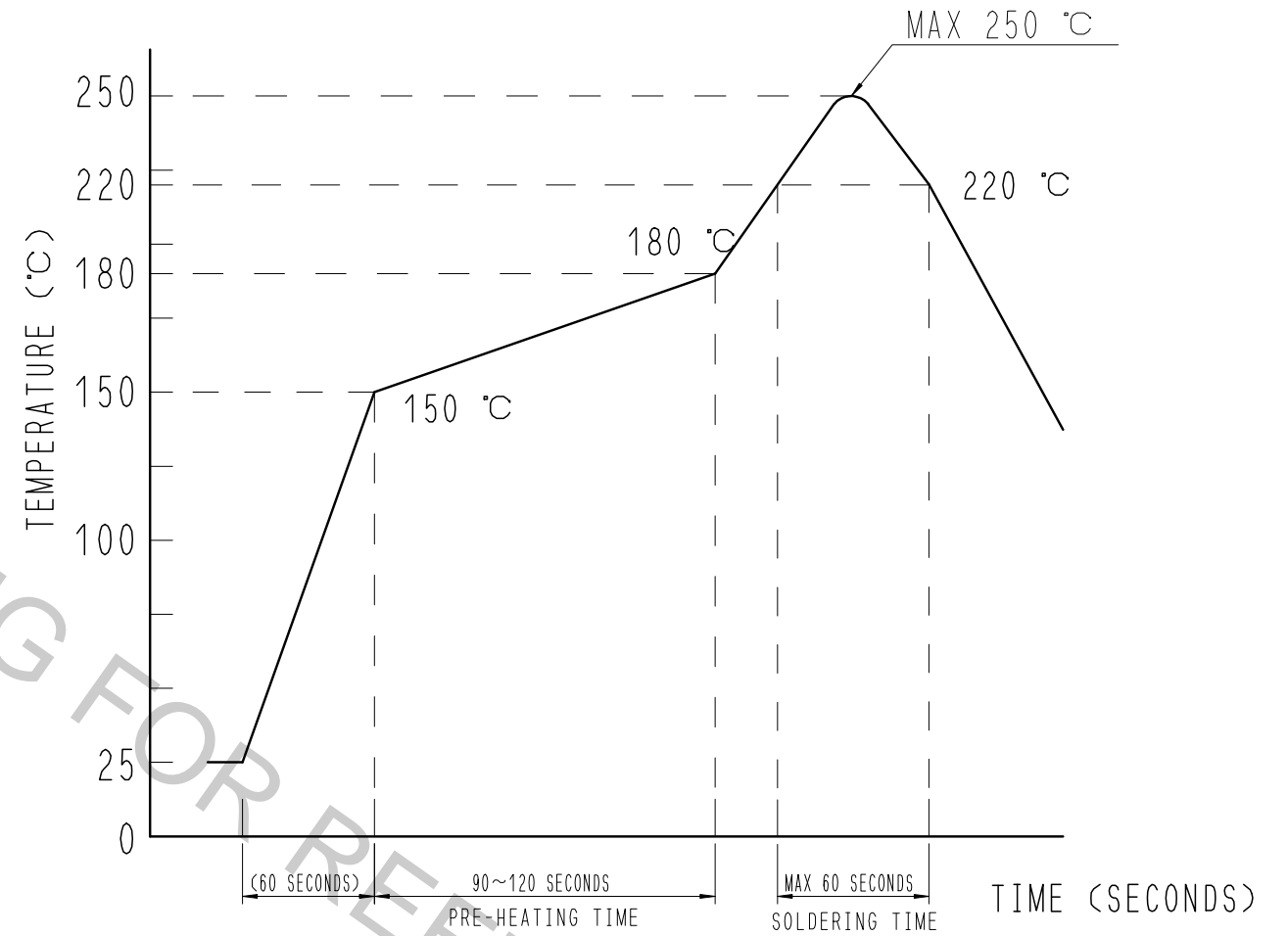

REFLOW METHOD: IR REFLOW
 NUMBER OF REFLOW CYCLES: 2 CYCLES MAX.
 1) REFLOW TIME
 DURATION ABOVE 220°C, 60 SEC MAX.
 (PEAK TEMPERATURE: 250°C MAX)
 2) PRE-HEAT TIME
 PRE-HEAT TEMPERATURE (MIN): 150°C
 PRE-HEAT TEMPERATURE (MAX): 180°C
 PRE-HEAT TIME: 90-120 SEC.

6 THIS TEMPERATURE PROFILE IS PER THE CONDITIONS SHOWN ABOVE. ADDITIONAL FACTORS, SUCH AS SOLDER PASTE TYPE, PCB SIZE AND OTHER MOUNTED COMPONENTS COULD AFFECT THE PROFILE. THEREFORE, A THOROUGH EVALUATION OF MOUNTING CONDITION IS REQUIRED PRIOR TO PRODUCTION. TEMPERATURE IS MEASURED AT CONTACT LEAD.
 7 PLEASE CONTACT US IN CASE YOU WILL MAKE DIFFERENT SETTINGS FROM OUR RECOMMENDATION.

	DRAWING NO.	EDC3-*****	PART NO.	BM23FR0.6-***DP-0.35V(51)
	SCALE	10:1	CODE NO	CL 66**-*****-***
UNITS	mm	HRS HIROSE KOREA CO., LTD.		2/3

Aug.1.2018 Copyright 2018 HIROSE ELECTRIC CO., LTD. All Rights Reserved.
 In case that the application demands a high level of reliability, such as automotive,
 please contact a company representative for further information.

EMBOSSED CARRIER TAPE PACKAGING (5:1)

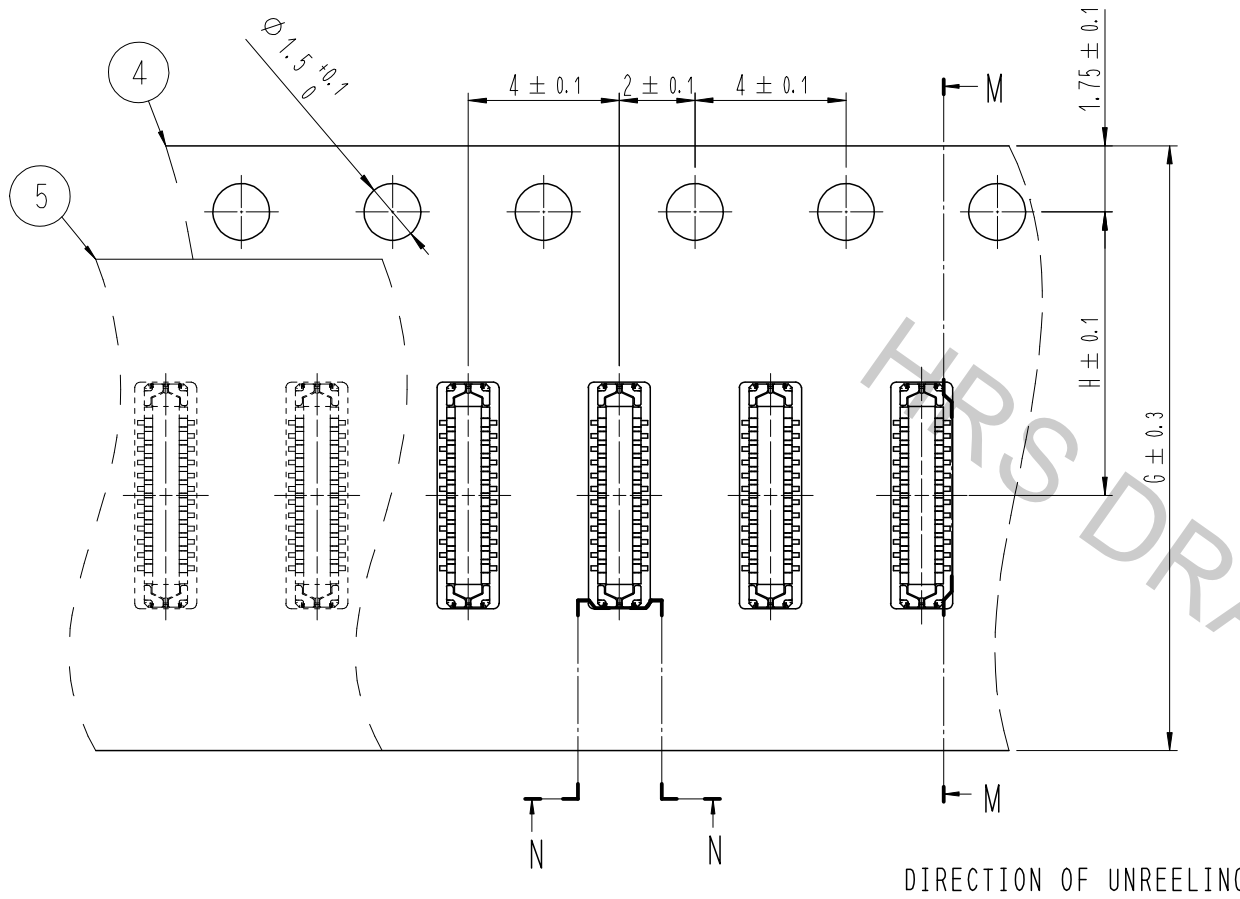

M-M (5:1)

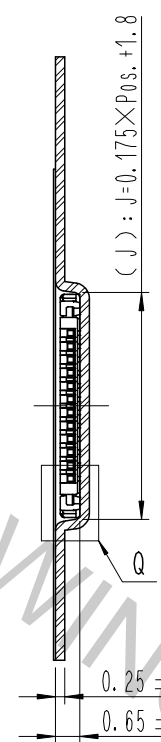

Q (10:1)

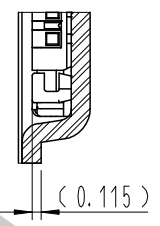

△ STYLE AND DIMENTION OF REEL (FREE)

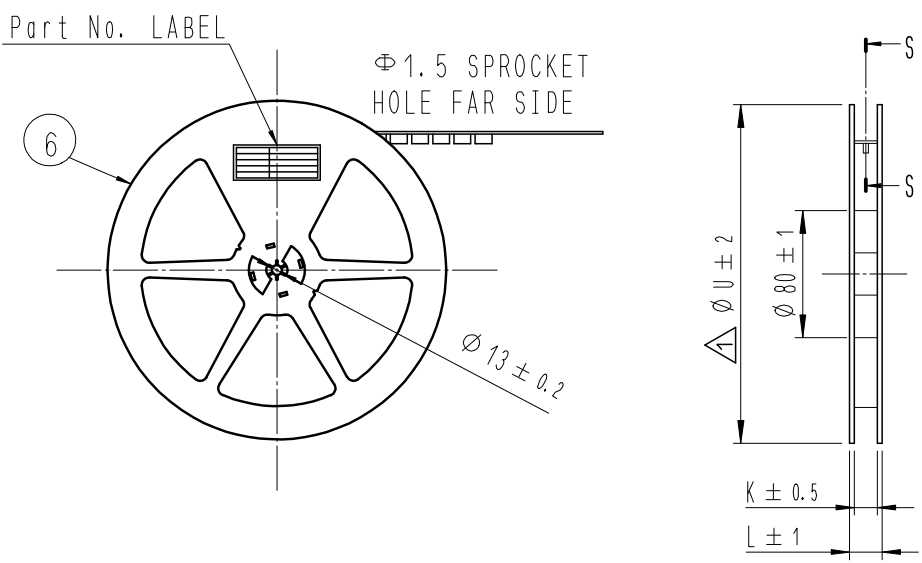

S-S (FREE)

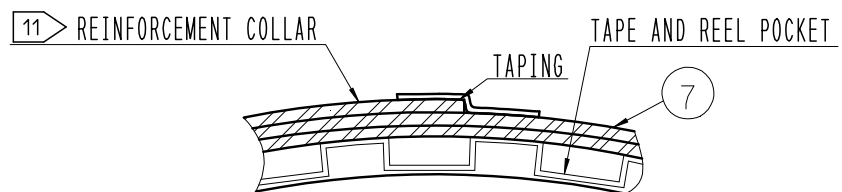

DIRECTION OF UNREELING

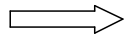

N-N (5:1)

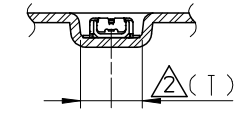

△ POS.	G	H	J	K	L	T	U
6	12	5.5	2.85	13.5	17.5	1.58	330
8	12	5.5	3.20	13.5	17.5	1.58	330
10	12	5.5	3.55	13.5	17.5	1.64	380
12	12	5.5	3.90	13.5	17.5	1.64	330
16	16	7.5	4.60	17.5	21.5	1.64	330
20	16	7.5	5.30	17.5	21.5	1.64	380
24	16	7.5	6.00	17.5	21.5	1.64	380
30	16	7.5	7.05	17.5	21.5	1.64	330
34	16	7.5	7.75	17.5	21.5	1.64	380
40	24	11.5	8.80	25.5	29.5	1.64	330
50	24	11.5	10.55	25.5	29.5	1.64	330

DETAIL OF PART No. LABEL

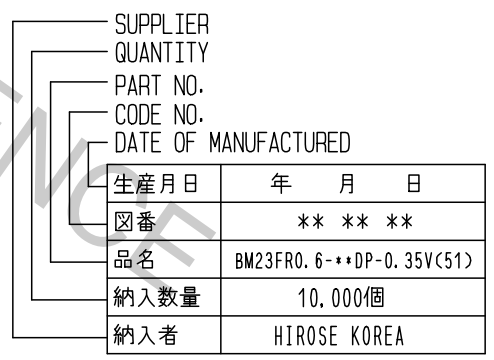

10 TAPING(FREE)

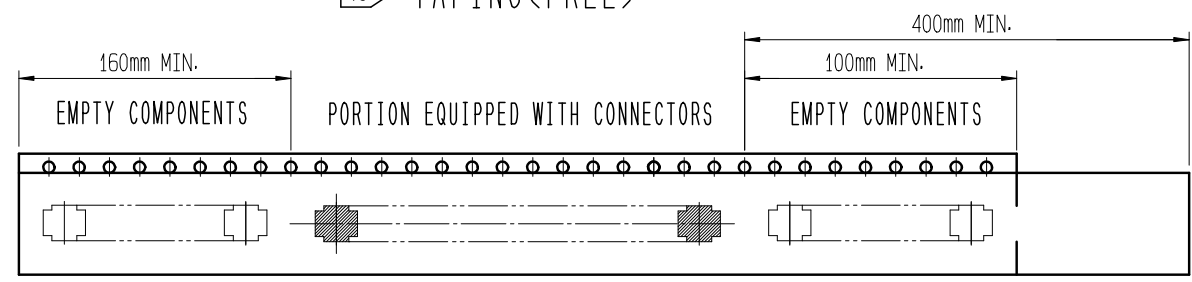

- 8 . PER REEL 10,000 CONNECTORS.
- 9 . THE DIMENSIONS IN PARENTHESES ARE FOR REFERENCE.
- 10 REFER TO JIS C 0806, IEC-60286-3 (PACKAGING OF COMPONENTS FOR AUTOMATIC HANDLING)
- 11 AFTER PACKAGING, ROLL 2 METERS OF THE REINFORCEMENT COLLAR TO OUTER CIRCUMFERENCE OF TAPE AND REEL POCKET. AND TAPE DOWN AT THE END THE COLLAR.

DRAWING NO. EDC3-*****	PART NO. BM23FR0.6-**-DP-0.35V(51)	CODE NO. CL 66**-*****-***	3/3
HIROSE ELECTRIC CO., LTD.			