

**PRE - ASSEMBLY INSTRUCTIONS:**

**Caution:** Check gasket on top of pedestal unit for damage before assembly. If cut or torn, contact Hammond Manufacturing for immediate replacement.

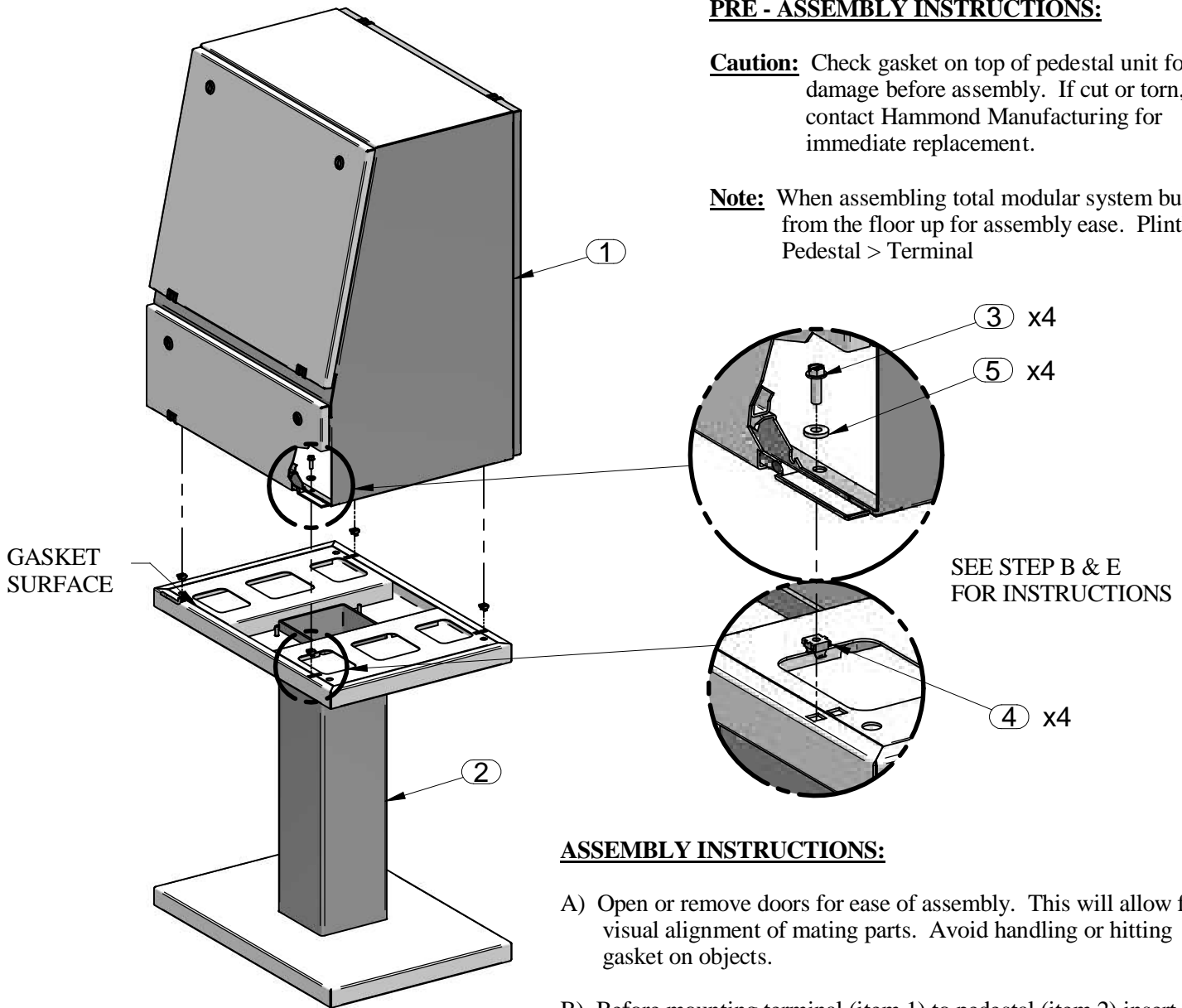

**Note:** When assembling total modular system build from the floor up for assembly ease. Plinth > Pedestal > Terminal



**ASSEMBLY INSTRUCTIONS:**

- A) Open or remove doors for ease of assembly. This will allow for visual alignment of mating parts. Avoid handling or hitting gasket on objects.
- B) Before mounting terminal (item 1) to pedestal (item 2) insert 1/4-20 clip nuts (item 4) into slots on top of pedestal.
- C) Align terminal (item 1) over top opening in pedestal (item 2). Side edges of terminal and pedestal are to be flush
- D) Front and rear slots in terminal bottom are to be aligned with mounting slots on pedestal top.
- E) Once the terminal is seated properly on the pedestal assemble using 1/4-20 x 0.75 hex hd. screws, sealing washers and 1/4-20 clip nuts (items 3, 4 & 5) provided. Torque screws and nuts to 115 in/lbs.

PARTS LIST		
ITEM No.	DESCRIPTION	QTY
1	TERMINAL	1
2	PEDESTAL	1
3	1/4-20 X 3/4 HEX CAP SCREW	4
4	1/4-20 CLIP NUT	4
5	1/4 SEALING WASHER	4

<p>TOOL BOX</p> 	<p>3/8, 7/16" Socket Wrench</p> 
--	---

