

ATLANTIC VERSION TERMINATOR INTERFACE ADAPTER	PART NUMBER	REVISION	DESCRIPTION	FEED TYPE	APPLICATOR STYLE CONVERSION CHART						
					CONVERT TO	PART NUMBERS REQUIRED					
	2150388-1	B	FINE CRIMP HEIGHT ADJUST	MECHANICAL	PNEUMATIC FEED	2119950-1	2119792-1	-	2119641-1	-	2063440-1
	2150388-2	B	FINE CRIMP HEIGHT ADJUST	PNEUMATIC	SERVO LATCH PLATE	2119951-1	1901697-1	8-2150388-5	-	-	2168400-7 (QUANTITY 2)
					SMART APPLICATOR	2161326-1	-	8-2150388-4	-	-	-
					MECHANICAL FEED	2119949-1	2063961-1	5-18022-5	2119653-1	-	-
	2150388-5	B	FINE CRIMP HEIGHT ADJUST	SERVO LATCH PLATE	SERVO LATCH PLATE	2119951-1	1901697-1	8-2150388-5	-	-	2168400-7 (QUANTITY 2)
					SMART APPLICATOR	2161326-1	-	8-2150388-4	-	-	-
	2150388-6	B	NON-CRIMP HEIGHT ADJUST	SERVO LATCH PLATE	SERVO LATCH PLATE	MECHANICAL FEED	2119949-1	2063961-1	5-18022-5	2119653-1	-
2150388-7	B	FINE CRIMP HEIGHT ADJUST	PNEUMATIC FEED			2119950-1	2119792-1	-	2119641-1	-	2063440-1
7-2150388-7	A	CRIMP TOOLING KIT	-	-	-	-	-	-	-	-	-

APPLICATOR DATA		
CRIMP	SIZE	TYPE
WIRE	2.64 mm [.104]	F
INSUL	3.68 mm [.145]	OV
APPLICATOR INSTRUCTIONS 408-10390		

TERMINAL DATA: G & H TERMINAL		TE CRIMP SPECIFICATION	
TERMINAL NAME: FLACHSTECKHULSE 4.80 x 0.8 FASTON			
WIRE STRIP LENGTH		INSULATION DIAMETER RANGE	
5.00-5.00 mm [.197-.197 IN]		Ø2.10-3.10 mm [.083-.122 IN]	
TERMINAL APPLICATION SPECIFICATION	25312	-	-
TERMINALS APPLIED			
TE TERMINAL	G & H TERMINAL	TE TERMINAL	G & H TERMINAL
1572180-1	25312.213.011	1572180-8	25312.123.327
1572180-2	25312.417.328	1572180-9	25312.123.324
1572180-3	25312.417.031	1-1572180-0	25312.123.210
1572180-4	25312.213.178	1-1572180-1	25312.123.211
1572180-5	25312.213.042	1-1572180-2	25312.123.204
1572180-6	25312.213.004	1-1572180-3	25312.123.178
1572180-7	25312.123.330		

WIRE SIZE	CRIMP HEIGHT mm [INCH]	CRIMP HEIGHT REFERENCE SETTING
2 X 1.00mm ²	1.75 +/- 0.05 [.069 +/- .002]	4.4
2.50mm ²	1.70 +/- 0.05 [.067 +/- .002]	5.0
1.50mm ²	1.50 +/- 0.05 [.059 +/- .002]	7.0

- 1 RECOMMENDED SPARE PARTS
- 2 GREASE BEARING SURFACES LIGHTLY
- 3 LUBRICATE DAILY PER THE APPLICATOR INSTRUCTION SHEET SUPPLIED WITH THE APPLICATOR.
- 4 APPLICATOR SPECIFIC DATA TO BE ENTERED INTO BLANK MEMORY CHIP AT ASSEMBLY. SEE BELOW FOR PART NUMBER:
 MECHANICAL FEED WITH "SMART APPLICATOR" CONVERSION: 8-2150388-4
 PNEUMATIC FEED WITH "SMART APPLICATOR" CONVERSION: 8-2150388-4
 SERVO FEED WITH "FINE CRIMP HEIGHT ADJUST": 8-2150388-5
 SERVO FEED WITH "NON-CRIMP HEIGHT ADJUST": 8-2150388-6
- 5 ADJUSTMENT OF THE STRIPPER MAY BE REQUIRED WHEN MOVING THE APPLICATOR BETWEEN BENCH AND LEADMAKER APPLICATIONS.
- 6 APPLY PART NUMBER 1-23419-5 LOCTITE TO THREADS OF ITEMS 62 & 180. APPLY PART NUMBER 2-23419-6 LOCTITE TO THREADS OF ITEM 242. FOR -6 ONLY APPLY PART NUMBER 1-23419-5 LOCTITE TO THREADS OF ITEM 37.
- 7 GREASE THREADS, GROOVE AND O-RING ON ITEMS 35 & 252.
- 8 MAGNET, ITEM 166 MUST BE ORIENTED CORRECTLY IN ORDER TO PROPERLY ACTUATE THE COUNTER.
- 9 CRIMP HEIGHT REFERENCE SETTING WAS THE SETTING USED WHEN THE APPLICATOR WAS QUALIFIED AT THE FACTORY. ADJUSTMENT MAY BE NECESSARY WHEN RUNNING APPLICATOR IN THE FIELD.
- 10 SPARE FEED CAM STORAGE LOCATION REFER TO INSTRUCTION SHEET FOR ADDITIONAL INFORMATION.
- 11 THE RECOMMENDED SET-UP FOR END FEED APPLICATORS IS POST-FEED WITH ITEM 2119653-1. THE APPLICATOR CAN BE CONFIGURED FOR PRE-FEED WITH ITEM 2119652-1 BUT MAY ENCOUNTER PROBLEMS WITH SOME APPLICATIONS. FEED ISSUES OR TERMINAL JAMMING MAY OCCUR IN THE PRE-FEED CONFIGURATION.
- 12 WHEN ASSEMBLING -6 NON-CRIMP HEIGHT ADJUST APPLICATOR USE SHIM PACK 2119957-2 TO ALIGN APPLICATOR'S MAXIMUM WIRE CRIMP HEIGHT AT NORMAL TERMINATOR SHUT HEIGHT
- 13 TERMINAL LUBRICANT IS RECOMMENDED.

***WARNING**
 ON INSTALLATION, SET WIRE DISC, ITEM 40 TO LARGEST WIRE SIZE SETTING. USE OF SETTINGS BELOW MINIMUM REQUIRED CRIMP HEIGHT SETTING WILL CAUSE DAMAGE TO CRIMP TOOLING.

-77	-7	-6	-5	-2	-1	PART NO	DESCRIPTION	ITEM NO
-	-	1	-	-	-	2119957-2	APPLICATOR SHIM PACK	260
-	1	-	1	1	1	8-21084-0	O-RING, .676 ID, .070 DIA. MAT.	252
-	-	-	-	1	-	2119640-1	PUSH ROD, AIR FEED	250
-	-	-	-	1	-	1803259-1	BUSHING, FLANGED	249
-	-	-	-	1	-	2119641-1	FEED CAM, AIR FEED	248
-	1	-	1	1	1	2119798-1	DETENT PIN	247

ATLANTIC VERSION
 Shown on sheets 1 of 4 & 2 of 4
 (Pacific version shown on sheets 3 of 4 & 4 of 4)

SET UP GAUGE	LOC	DIST	REVISIONS					
2119599-2	A	66	P	LTN	DESCRIPTION	DATE	OWN	APVD
			A		RELEASED	18DEC2013	LG	TE
			B		ECR-17-005523	17APR2017	TB	CT

-	1	-	1	1	1	1-22279-3	SPRING, COMPRESSION	246
-	-	1	-	-	-	2119759-1	RAM, AMP STYLE, END FEED, NON-ADJUST	245
-	1	1	1	1	1	2119082-9	CAM, SNAIL, INSULATION ADJUSTMENT	244
-	1	1	1	1	1	2079764-1	WASHER, WAVE SPRING, CREST-TO-CREST	243
-	1	1	1	1	1	2119083-1	RETAINER, INSULATION DIAL	242
-	-	2	2	-	-	2168400-7	SHCS, LOW HEAD, RoHS, M5 X 10	240
-	-	-	-	-	1	2119580-1	MECHANICAL FEED ASSEMBLY	239
-	-	-	-	1	-	2063440-1	AIR FEED MODULE	238
-	-	1	1	-	-	2119740-2	TAG, IDENTIFICATION	213
-	-	REFREF	-	-	-	1901697-1	FEED FINGER ASSEMBLY, EF	183
-	1	1	1	1	1	1752354-4	STANDOFF, HOLD-DOWN	180
-	1	1	1	1	1	6-993111-6	PIN, SLOTTED SPRING 3.0 X 14.0	177
-	1	1	1	1	1	8-22280-7	SPRING, COMPRESSION	176
-	1	1	1	1	1	1752353-2	GUIDE PIN, HOLDDOWN	175
-	1	1	1	1	1	1901680-2	GUIDE PIN, HOLDDOWN	174
-	-	-	-	2	-	21045-3	RING, RETAIN, EXTERN, 3/16 CRESCENT	172
-	1	1	1	1	1	994969-1	MAGNET, RARE EARTH HIGH ENERGY	166
-	REFREF	REFREF	REFREF	REFREF	REFREF	994970-2	COUNTER, MAGNETIC	164
-	-	-	-	1	-	240638-1	SPRING, FEED FINGER	163
-	-	-	-	1	-	3-23627-7	PIN, RETAIN, GRVD, 3/16 X .854	137
-	-	REFREF	-	-	-	SEE NOTE 4	MEMORY CHIP, PROGRAMMED	135
-	-	1	1	-	-	1633743-1	SERVO FEED LATCH ASM	133
-	1	1	1	1	1	2119955-2	ASSY, LUBRICATOR, END FEED	84
-	1	1	1	1	1	455888-6	SPACER, CRIMPER	82
-	1	1	1	1	1	2119956-2	DOCUMENTATION PACKAGE	71
-	2	2	2	2	2	2-18032-2	SCR, SET, FLT POINT M3 X 10.0	70
-	1	-	-	1	1	2119740-1	TAG, IDENTIFICATION	67
-	2	2	2	2	2	2168078-1	SCREW, DRIVE, RH, RoHS, 2 x .188	66
-	1	1	1	1	1	1901681-5	HOLDDOWN, TERMINAL	65
-	1	-	1	1	1	2119793-1	LIMITER, ADJUSTMENT BOLT	63
-	3	-	3	3	3	992763-5	SCR, SET, SOC, CONE POINT, M3 X 4.0	62
-	1	1	1	1	1	2079383-4	SCR, BHSC, RoHS (M4 X 8)	60
-	-	-	-	-	1	5-18022-5	SCR, HEX HD CAP, M4 X 6.0	59
-	-	-	-	-	1	2063961-1	FEED FINGER	58
-	4	4	4	4	4	2168400-4	SHCS, LOW HEAD, RoHS, M4 X 8	57
-	2	2	2	2	2	1-2168083-0	SCR, SKT HD CAP, RoHS, M4 X 10	56
-	2	2	2	2	2	5018030-2	NUT, HEX, REG, RoHS, M4	55
-	2	2	2	2	2	5018030-1	NUT, HEX, REG, RoHS, M3	54
-	2	2	2	2	2	986965-8	NUT, LOCK, HEX, TORQUE (M4)	53
-	1	1	1	1	1	1-5018030-0	NUT, HEX, REG, RoHS, M3.5	52
-	-	-	-	-	1	2119792-1	PAWL, EF, AIR	51
-	-	-	-	1	2	18023-9	SCR, SKT HD CAP M4 X 6.0	49
-	-	-	-	-	1	2119652-1	FEED CAM, PRE FEED	48
-	-	-	-	-	1	2119653-1	FEED CAM, POST FEED	47
-	1	1	1	1	1	2119655-5	APPLICATOR BASIC ASSEMBLY, EF	46
-	1	-	1	1	1	2119369-1	RAM, AMP STYLE, END FEED	44
-	1	1	1	1	1	2079383-7	SCR, BHSC, RoHS (M8 X 25)	41
-	1	-	1	1	1	2119645-1	DISC, NUMBERED FA WIRE ADJUSTMENT	40
-	1	-	1	1	1	2119957-1	APPLICATOR SHIM PACK	39
-	1	1	1	1	1	1-2119644-2	RAM WASHER, PRECISION	38
-	1	1	1	1	1	2119085-1	FA HEAD, ATLANTIC STYLE	37
-	1	-	1	1	1	2119092-1	BOLT, ADJUSTMENT	35
-	8	8	8	8	8	1-18028-2	WASHER, FLAT, REG M4	33
-	2	2	2	2	2	2079383-8	SCR, BHSC, RoHS (M4 X 16)	31
-	2	2	2	2	2	1-2168083-0	SCR, SKT HD CAP, RoHS, M4 X 10	29
-	1	1	1	1	1	240639-1	STRIPPER (MACHINING)	27
-	2	2	2	2	2	1320906-1	STUD, THREADED	25
-	1	1	1	1	1	1752371-5	PLATE, STRIP GUIDE	24
-	2	2	2	2	2	2-22281-3	SPRING, COMPRESSION	22
-	1	1	1	1	1	1752373-4	DRAG	20
-	2	2	2	2	2	1901259-5	GUIDE, LOWER STRIP	18
-	4	4	4	4	4	1-2079383-1	SCR, BHSC, RoHS (M6 X 12)	17
-	1	1	1	1	1	240644-1	PLATE, REAR SHEAR	11
-	-	-	-	-	-	-	-	10
-	1	1	1	1	1	1-690482-2	PLATE, FRONT SHEAR	9
1	1	1	1	1	1	3-1803001-3	ANVIL, COMBINATION, END FEED	8
-	1	1	1	1	1	2217206-7	BLADE, SLUG	7
-	-	-	-	-	-	-	-	6
-	1	1	1	1	1	4-240641-1	SPACER	5
-	1	1	1	1	1	238009-1	BLOCK, FL CRIMPER SPACER	4
1	1	1	1	1	1	1633963-5	CRIMPER, INSULATION OVERLAP PREMIUM	3
-	1	1	1	1	1	455888-5	SPACER, CRIMPER	2
1	1	1	1	1	1	9-1633305-1	CRIMPER, WIRE PREMIUM	1

DIMENSIONS:		TOLERANCES UNLESS OTHERWISE SPECIFIED:		DWG		CHK		APVD		NAME	
mm	0 PLC ±	1 PLC ±	2 PLC ±	3 PLC ±	4 PLC ±	H. HUANG	18OCT2013	L. ZHANG	18OCT2013	U. GUO	18OCT2013
	0 PLC ±	1 PLC ±	2 PLC ±	3 PLC ±	4 PLC ±	TE Connectivity		Harrisburg, PA 17105-3608		Ocean End Feed Applicator	
MATERIAL:	FINISH:	WEIGHT:	SCALE:	SHEET:	REV:	Customer Accessible Production Drawing		SCALE: 1:1		SHEET 1 OF 4	

LOC		DIST		REVISIONS			
A	66	P	LTM	DESCRIPTION	DATE	OWN	APVD
		-		SEE SHEET 1			

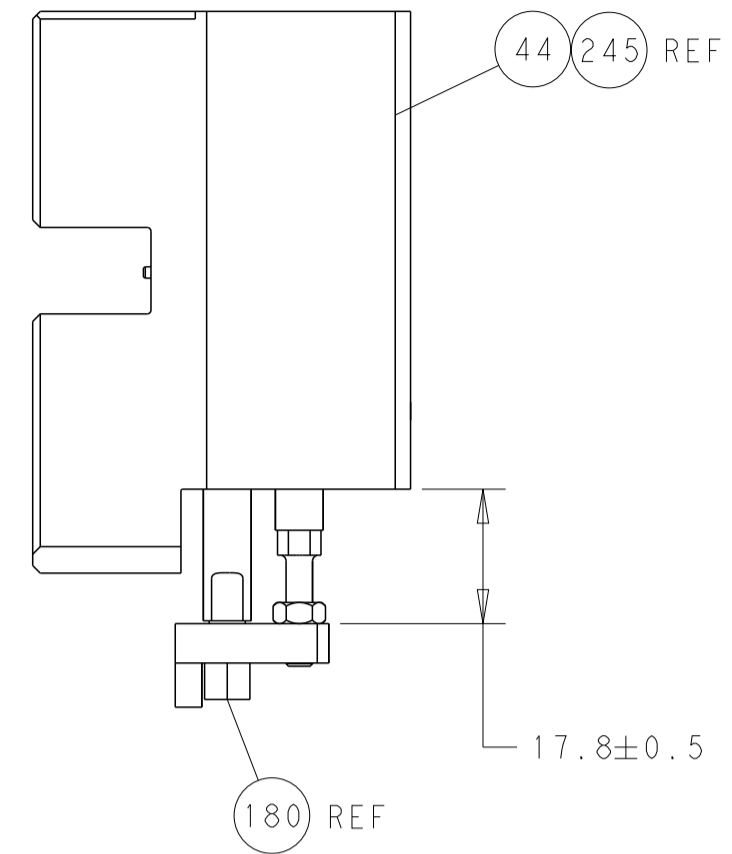

HOLDDOWN SET-UP

FEED TYPE
MECHANICAL

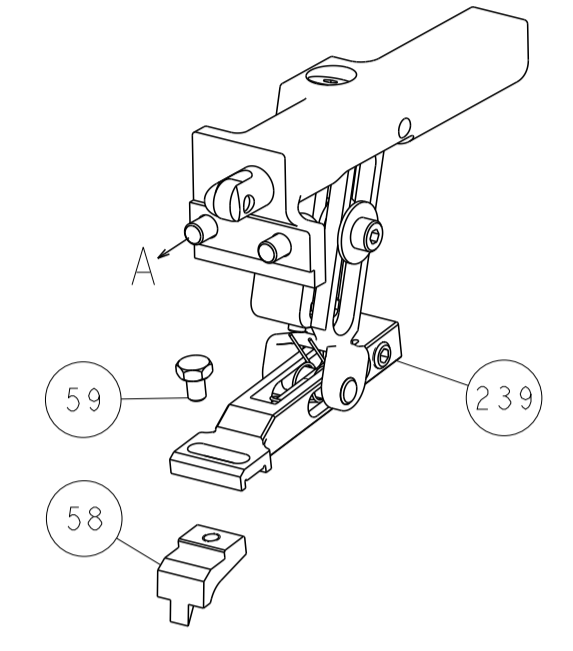

PNEUMATIC

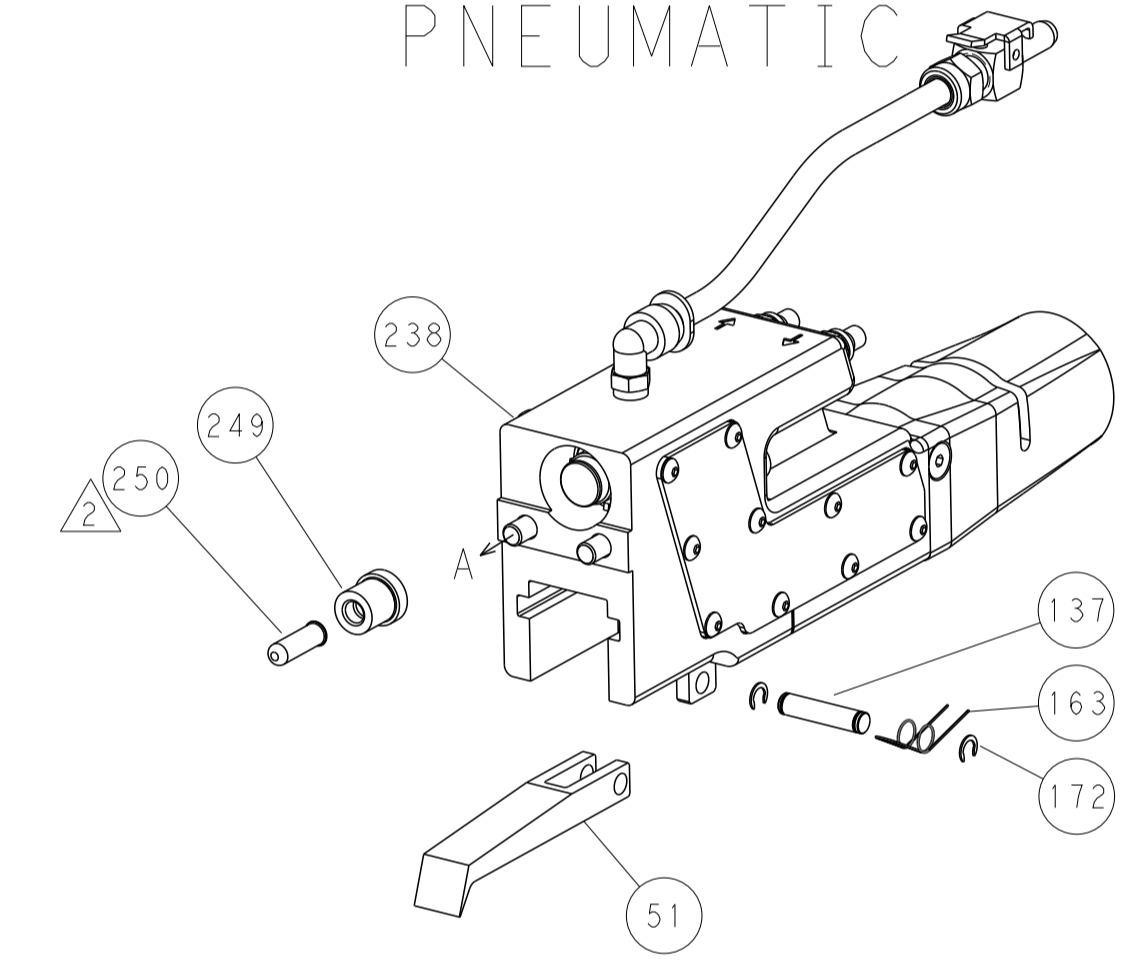

SERVO
LATCH PLATE

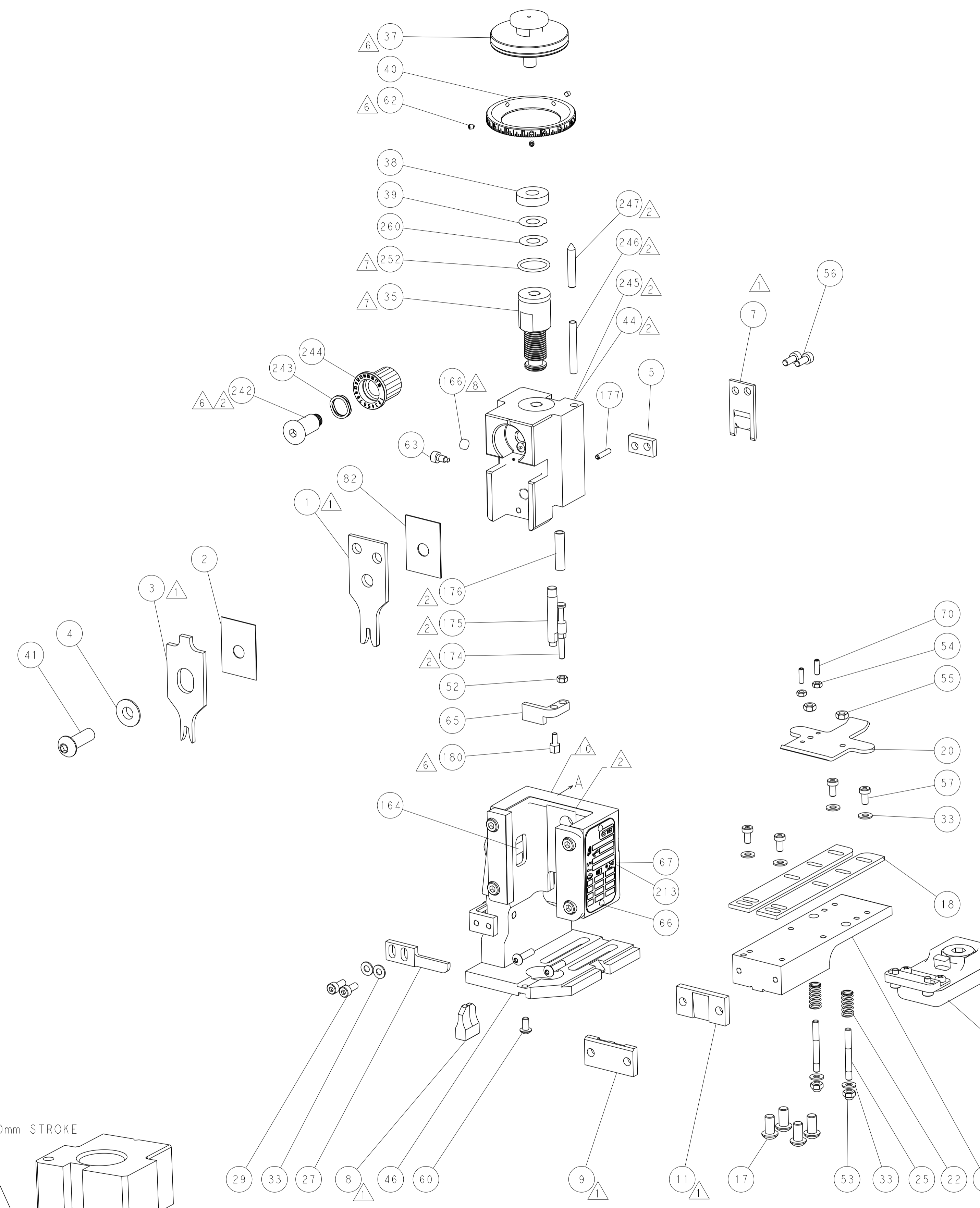
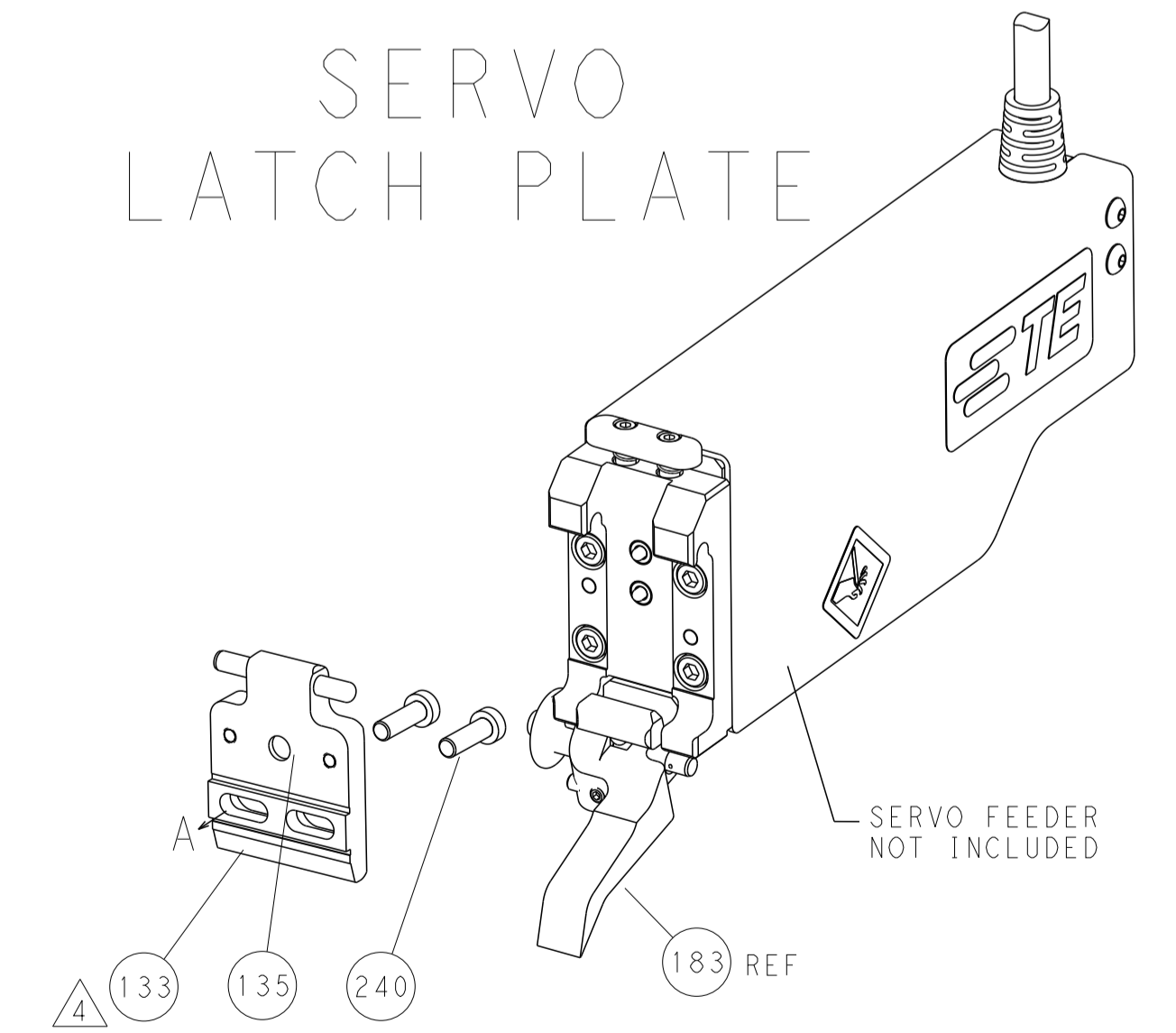

CAM POSITIONS

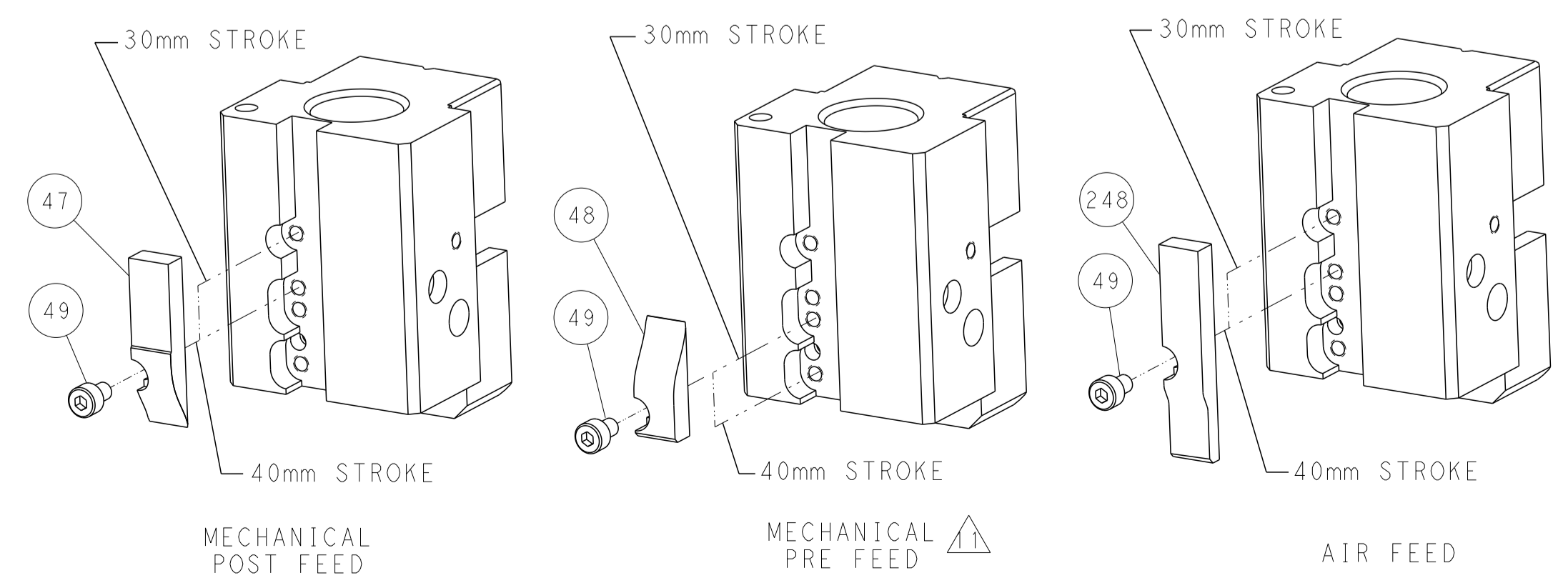

ATLANTIC VERSION
 Shown on sheets 1 of 4 & 2 of 4
 (Pacific version shown on sheets 3 of 4 & 4 of 4)

DIMENSIONS:		TOLERANCES UNLESS OTHERWISE SPECIFIED:		DWN K. HUANG 18OCT2013		TE Connectivity	
mm	0 PLC ±	1 PLC ±	2 PLC ±	3 PLC ±	4 PLC ±	5 PLC ±	Harrisburg, PA 17105-3608
MATERIAL:	FINISH:	WEIGHT:	SCALE:	SIZE:	CAGE CODE:	DRAWING NO:	RESTRICTED TO:
			1:1	A1	00779	©=2150388	
Customer Accessible Production Drawing				SHEET 2 OF 4 REV B			

PACIFIC VERSION TERMINATOR INTERFACE ADAPTER	PART NUMBER	REVISION	DESCRIPTION	FEED TYPE	APPLICATOR STYLE CONVERSION CHART						
					CONVERT TO	PART NUMBERS REQUIRED					
	2-2150388-1	B	FINE CRIMP HEIGHT ADJUST	MECHANICAL	PNEUMATIC FEED	2119950-1	2119792-1	-	2119641-2	-	2063440-1
					SERVO LATCH PLATE	2119951-1	1901697-1	8-2150388-5	-	2168400-7 (QUANTITY 2)	
					SMART APPLICATOR	2161326-1	-	8-2150388-4	-	-	
	2-2150388-2	B	FINE CRIMP HEIGHT ADJUST	PNEUMATIC	MECHANICAL FEED	2119949-1	2063961-1	5-18022-5	2119653-2	-	-
					SERVO LATCH PLATE	2119951-1	1901697-1	8-2150388-5	-	2168400-7 (QUANTITY 2)	
					SMART APPLICATOR	2161326-1	-	8-2150388-4	-	-	
	2-2150388-5	B	FINE CRIMP HEIGHT ADJUST	SERVO LATCH PLATE	MECHANICAL FEED	2119949-1	2063961-1	5-18022-5	2119653-2	-	-
					PNEUMATIC FEED	2119950-1	2119792-1	-	2119641-2	-	2063440-1
	2-2150388-7	B	FINE CRIMP HEIGHT ADJUST	NONE	-	-	-	-	-	-	-
	7-2150388-7	A	CRIMP TOOLING KIT	-	-	-	-	-	-	-	-

APPLICATOR DATA		
CRIMP	SIZE	TYPE
WIRE	2.64 mm [1.041]	F
INSUL	3.68 mm [1.451]	OV
APPLICATOR INSTRUCTIONS 408-10390		

TERMINAL DATA: G & H TERMINAL		TE CRIMP SPECIFICATION	
TERMINAL NAME: FLACHSTECKHULSE 4.80 x 0.8 FASTON			
WIRE STRIP LENGTH 5.00-5.00 mm [1.97-.197 IN]		INSULATION DIAMETER RANGE Ø2.10-3.10 mm [1.083-.122 IN]	
TERMINAL APPLICATION SPECIFICATION	25312	-	-
TERMINALS APPLIED			
TE TERMINAL	G & H TERMINAL	TE TERMINAL	G & H TERMINAL
1572180-1	25312.213.011	1572180-8	25312.123.327
1572180-2	25312.417.328	1572180-9	25312.123.324
1572180-3	25312.417.031	1-1572180-0	25312.123.210
1572180-4	25312.213.178	1-1572180-1	25312.123.211
1572180-5	25312.213.042	1-1572180-2	25312.123.204
1572180-6	25312.213.004	1-1572180-3	25312.123.178
1572180-7	25312.123.330		

WIRE SIZE	CRIMP HEIGHT mm [INCH]	CRIMP HEIGHT REFERENCE SETTING
2 x 1.00mm ²	1.75 +/- 0.05 [1.069 +/- .002]	4.4
2.50mm ²	1.70 +/- 0.05 [1.067 +/- .002]	5.0
1.50mm ²	1.50 +/- 0.05 [1.059 +/- .002]	7.0

- RECOMMENDED SPARE PARTS
- GREASE BEARING SURFACES LIGHTLY
- LUBRICATE DAILY PER THE APPLICATOR INSTRUCTION SHEET SUPPLIED WITH THE APPLICATOR.
- APPLICATOR SPECIFIC DATA TO BE ENTERED INTO BLANK MEMORY CHIP AT ASSEMBLY. SEE BELOW FOR PART NUMBER:
 MECHANICAL FEED WITH "SMART APPLICATOR" CONVERSION: 8-2150388-4
 PNEUMATIC FEED WITH "SMART APPLICATOR" CONVERSION: 8-2150388-4
 SERVO FEED WITH "FINE CRIMP HEIGHT ADJUST": 8-2150388-5
- ADJUSTMENT OF THE STRIPPER MAY BE REQUIRED WHEN MOVING THE APPLICATOR BETWEEN BENCH AND LEADMAKER APPLICATIONS.
- APPLY PART NUMBER 1-23419-5 LOCTITE TO THREADS OF ITEMS 62 & 180. APPLY PART NUMBER 2-23419-6 LOCTITE TO THREADS OF ITEM 242.
- GREASE THREADS, GROOVE AND O-RING ON ITEMS 139 & 153.
- MAGNET, ITEM 166 MUST BE ORIENTED CORRECTLY IN ORDER TO PROPERLY ACTUATE THE COUNTER.
- CRIMP HEIGHT REFERENCE SETTING WAS THE SETTING USED WHEN THE APPLICATOR WAS QUALIFIED AT THE FACTORY. ADJUSTMENT MAY BE NECESSARY WHEN RUNNING APPLICATOR IN THE FIELD.
- SPARE FEED CAM STORAGE LOCATION REFER TO INSTRUCTION SHEET FOR ADDITIONAL INFORMATION.
- THE RECOMMENDED SET-UP FOR END FEED APPLICATORS IS POST-FEED WITH ITEM 2119653-1. THE APPLICATOR CAN BE CONFIGURED FOR PRE-FEED WITH ITEM 2119652-1 BUT MAY ENCOUNTER PROBLEMS WITH SOME APPLICATIONS. FEED ISSUES OR TERMINAL JAMMING MAY OCCUR IN THE PRE-FEED CONFIGURATION.
- TERMINAL LUBRICANT IS RECOMMENDED.

***WARNING**
 ON INSTALLATION, SET WIRE DISC, ITEM 40 TO LARGEST WIRE SIZE SETTING. USE OF SETTINGS BELOW MINIMUM REQUIRED CRIMP HEIGHT SETTING WILL CAUSE DAMAGE TO CRIMP TOOLING.

-77-27-25-22-21	PART NO	DESCRIPTION	ITEM NO
-	1 1 1 1	2119782-1 FINE ADJUST HEAD ASM, PACIFIC STYLE	251
-	- - 1 -	2119640-1 PUSH ROD, AIR FEED	250
-	- - 1 -	1803259-1 BUSHING, FLANGED	249
-	1 1 1 1	1-22279-3 SPRING, COMPRESSION	246

PACIFIC VERSION
 Shown on sheets 3 of 4 & 4 of 4
 (Atlantic version shown on sheets 1 of 4 & 2 of 4)

SET UP GAUGE	LOC	DIST	REVISIONS			
2119599-2	A	66	REV	DATE	BY	APPV
			-	SEE SHEET 1	-	-

REV	DATE	BY	APPV	DESCRIPTION	DATE	BY	APPV
-	1	1	1	1	2119082-9	CAM, SNAIL, INSULATION ADJUSTMENT	244
-	1	1	1	1	2079764-1	WASHER, WAVE SPRING, CREST-TO-CREST	243
-	1	1	1	1	2119083-1	RETAINER, INSULATION DIAL	242
-	-	2	-	-	2168400-7	SHCS, LOW HEAD, RoHS, M5 X 10	240
-	-	-	-	1	2119580-1	MECHANICAL FEED ASSEMBLY	239
-	-	-	-	1	2063440-1	AIR FEED MODULE	238
-	-	1	-	-	2119740-2	TAG, IDENTIFICATION	213
-	4	4	4	4	2079383-9	SCR, BHSC, RoHS (M6 X 20)	186
-	-	REF	-	-	1901697-1	FEED FINGER ASSEMBLY, EF	183
-	1	1	1	1	1752354-4	STANDOFF, HOLD-DOWN	180
-	1	1	1	1	6-993111-6	PIN, SLOTTED SPRING 3.0 X 14.0	177
-	1	1	1	1	8-22280-7	SPRING, COMPRESSION	176
-	1	1	1	1	1752353-2	GUIDE PIN, HOLDDOWN	175
-	1	1	1	1	1901680-2	GUIDE PIN, HOLDDOWN	174
-	-	-	2	-	21045-3	RING, RETAIN, EXTERN, 3/16 CRESCENT	172
-	-	-	-	1	994969-1	MAGNET, RARE EARTH HIGH ENERGY	166
-	REF	REF	REF	REF	994970-2	COUNTER, MAGNETIC	164
-	-	-	1	-	240638-1	SPRING, FEED FINGER	163
-	1	1	1	1	8-21084-1	O-RING, .801 ID, .070 DIA. MAT.	153
-	-	-	1	-	2119641-2	FEED CAM, AIR FEED	152
-	1	1	1	1	2119798-2	DETENT PIN	145
-	1	1	1	1	2079383-8	SCR, BHSC, RoHS (M4 X 16)	144
-	-	-	-	1	2119653-2	FEED CAM, POST FEED	142
-	1	1	1	1	2119655-6	APPLICATOR BASIC ASSEMBLY, EF	141
-	1	1	1	1	2119651-1	RAM, ASIAN STYLE, END FEED	140
-	1	1	1	1	2119092-2	BOLT, ADJUSTMENT	139
-	-	-	1	-	3-23627-7	PIN, RETAIN, GRVD, 3/16 X .854	137
-	-	REF	-	-	SEE NOTE 4	MEMORY CHIP, PROGRAMMED	135
-	-	1	-	-	1633743-1	SERVO FEED LATCH ASM	133
-	1	1	1	1	2119955-2	ASSY, LUBRICATOR, END FEED	84
-	1	1	1	1	455888-6	SPACER, CRIMPER	82
-	1	1	1	1	2119956-2	DOCUMENTATION PACKAGE	71
-	2	2	2	2	2-18032-2	SCR, SET, FLT POINT M3 X 10.0	70
-	1	-	1	1	2119740-1	TAG, IDENTIFICATION	67
-	2	2	2	2	2168078-1	SCREW, DRIVE, RH, RoHS, 2 x .188	66
-	1	1	1	1	1901681-5	HOLDDOWN, TERMINAL	65
-	1	1	1	1	2119793-1	LIMITER, ADJUSTMENT BOLT	63
-	3	3	3	3	992763-5	SCR, SET, SOC, CONE POINT, M3 x 4.0	62
-	-	-	-	1	5-18022-5	SCR, HEX HD CAP, M4 X 6.0	59
-	-	-	-	1	2063961-1	FEED FINGER	58
-	4	4	4	4	2168400-4	SHCS, LOW HEAD, RoHS, M4 X 8	57
-	2	2	2	2	1-2168083-0	SCR, SKT HD CAP, RoHS, M4 X 10	56
-	2	2	2	2	5018030-2	NUT, HEX, REG, RoHS, M4	55
-	2	2	2	2	5018030-1	NUT, HEX, REG, RoHS, M3	54
-	2	2	2	2	986965-8	NUT, LOCK, HEX, TORQUE (M4)	53
-	1	1	1	1	1-5018030-0	NUT, HEX, REG, RoHS, M3.5	52
-	-	-	-	1	2119792-1	PAWL, EF, AIR	51
-	-	-	-	2	18023-9	SCR, SKT HD CAP M4 X 6.0	49
-	-	-	-	1	2119652-1	FEED CAM, PRE FEED	48
-	1	1	1	1	2079383-7	SCR, BHSC, RoHS (M8 X 25)	41
-	1	1	1	1	2119645-1	DISC, NUMBERED FA WIRE ADJUSTMENT	40
-	1	1	1	1	2119957-1	APPLICATOR SHIM PACK	39
-	1	1	1	1	1-2119644-2	RAM WASHER, PRECISION	38
-	8	8	8	8	1-18028-2	WASHER, FLAT, REG M4	33
-	2	2	2	2	2079383-8	SCR, BHSC, RoHS (M4 X 16)	31
-	2	2	2	2	1-2168083-0	SCR, SKT HD CAP, RoHS, M4 X 10	29
-	1	1	1	1	240639-1	STRIPPER (MACHINING)	27
-	2	2	2	2	1320906-1	STUD, THREADED	25
-	1	1	1	1	1752371-5	PLATE, STRIP GUIDE	24
-	2	2	2	2	2-22281-3	SPRING, COMPRESSION	22
-	1	1	1	1	1752373-4	DRAG	20
-	2	2	2	2	1901259-5	GUIDE, LOWER STRIP	18
-	1	1	1	1	240644-1	PLATE, REAR SHEAR	11
-	-	-	-	-	-	-	10
-	1	1	1	1	1-690482-2	PLATE, FRONT SHEAR	9
-	1	1	1	1	3-1803001-3	ANVIL, COMBINATION, END FEED	8
-	1	1	1	1	2217206-7	BLADE, SLUG	7
-	-	-	-	-	-	-	6
-	1	1	1	1	4-240641-1	SPACER	5
-	1	1	1	1	238009-1	BLOCK, FL CRIMPER SPACER	4
-	1	1	1	1	1633963-5	CRIMPER, INSULATION OVERLAP PREMIUM	3
-	1	1	1	1	455888-5	SPACER, CRIMPER	2
-	1	1	1	1	9-1633305-1	CRIMPER, WIRE PREMIUM	1

DIMENSIONS:	TOLERANCES UNLESS OTHERWISE SPECIFIED:	DATE	BY	APPV	NAME	SIZE	CAGE CODE	DRAWING NO	RESTRICTED TO
mm	0 PLC ± 1 PLC ± 3 PLC ± 4 PLC ± ANGLES FINISH	18OCT2013	H. HUANG	L. ZHANG	U. GUO	A1	00779	2150388	B
Customer Accessible Production Drawing									

