

Apr.1.2017 Copyright 2017 HIROSE ELECTRIC CO., LTD. All Rights Reserved.

COUNT	DESCRIPTION OF REVISIONS	BY	CHKD	DATE	COUNT	DESCRIPTION OF REVISIONS	BY	CHKD	DATE
△				..	△				..
△				..	△				..
△				..	△				..

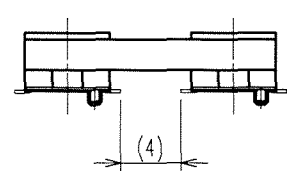

RECOMMENDED LAND PATTERN DIMENSION OF PCB (MOUNTING SIDE)

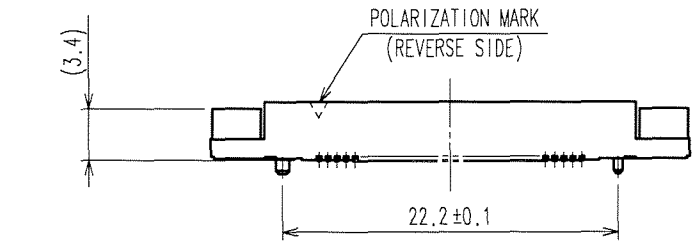
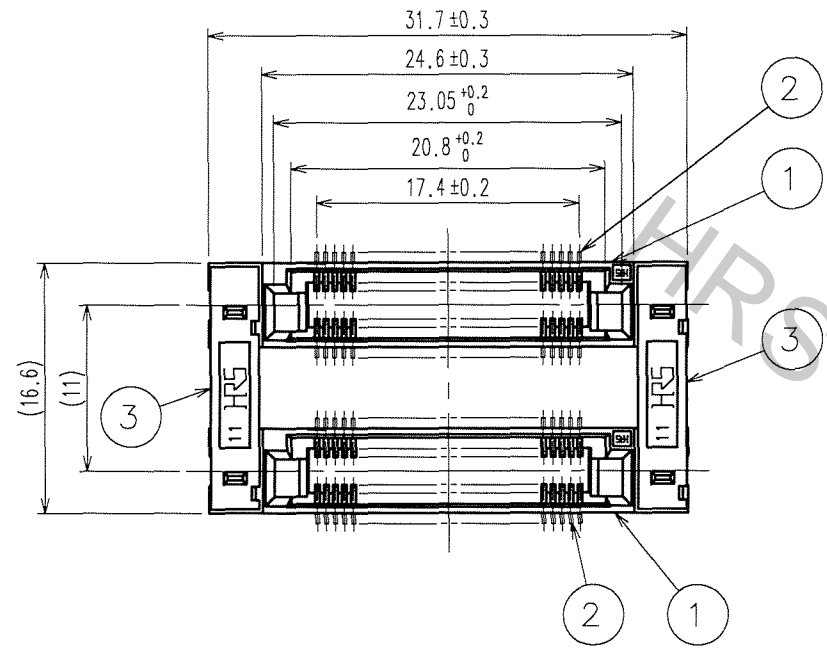
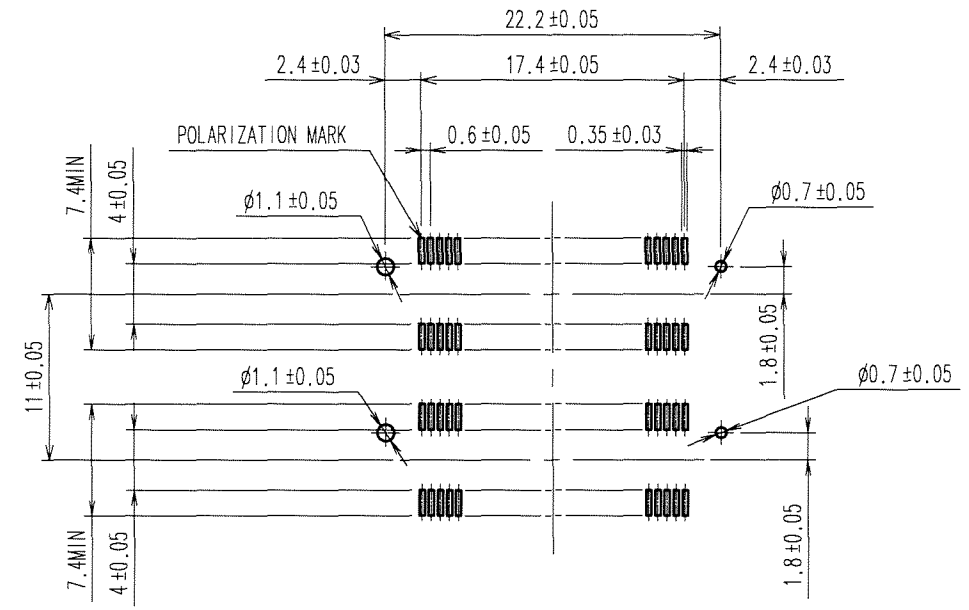

- NOTES
- 1 LEAD CO-PLANARITY SHALL BE 0.1mm MAX.
  - 2 AFTER MOUNTING BOARD, REF.NO.3 SHALL BE REMOVED.
  - 3 FOR MODIFICATION, ETC., PREVENTIVE HOLE FOR SINK MARK MAY BE ADDED DEPENDS ON CIRCUMSTANCES.
  - 4 THE DIMENSIONS IN PARENTHESES ARE FOR REFERENCE.

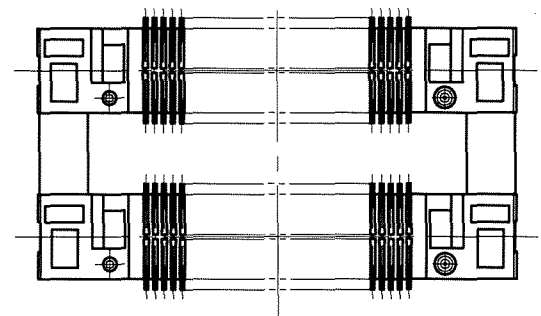

TO  
PCK

1, 3	PPS	LIGHT BROWN (UL94V-0)	2	PHOSPHOR BRONZE	CONTACT AREA: GOLD 0.1μm min LEAD AREA: GOLD FLASH UNDER PLATING: NICKEL 1.5μm min
NO.	MATERIAL	FINISH, REMARKS	NO.	MATERIAL	FINISH, REMARKS
CODE NO. (OLD) CL		DRAWN A. SUZUKAWA 06.10.27	DESIGNED <i>H. Nakamura</i> 06.10.27	CHECKED <i>H. Ozawa</i> 06.10.27	APPROVED <i>H. Okawa</i> 06.10.27
SCALE 2 : 1		DRAWING NO. EDC3-150961-25		PART NO. FX8C-60/60S11-SVJ(71)	
UNITS mm		DRAWING NO. <b>HRS</b> HIROSE ELECTRIC CO., LTD		CODE NO. CL578-0901-7-71	
					1/2

Apr.1.2017 Copyright 2017 HIROSE ELECTRIC CO., LTD. All Rights Reserved.

COUNT	DESCRIPTION OF REVISIONS	BY	CHKD	DATE	COUNT	DESCRIPTION OF REVISIONS	BY	CHKD	DATE
△				..	△				..
△				..	△				..
△				..	△				..

DETAIL AFTER REMOVING JOINT

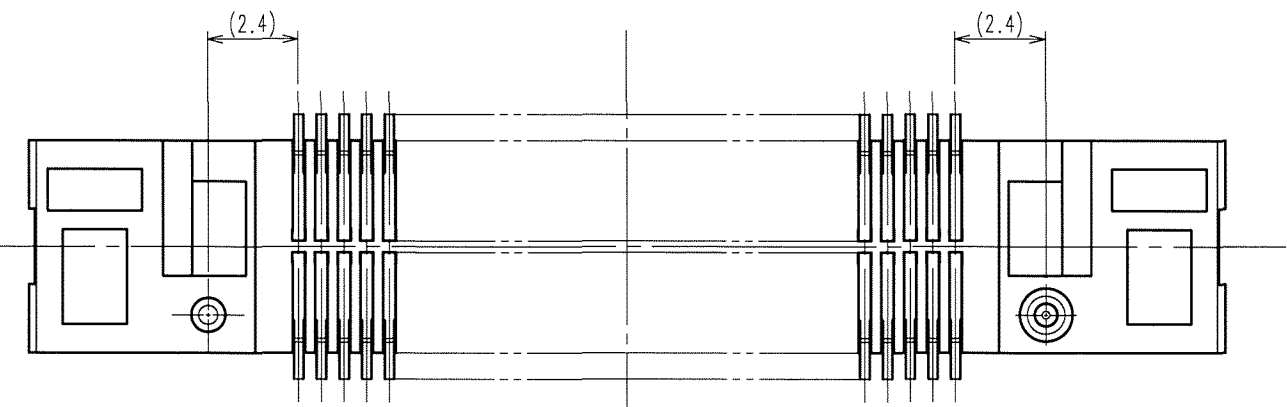
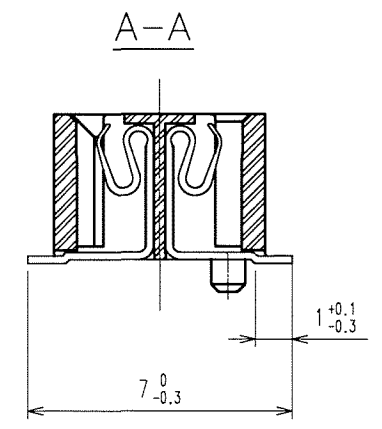
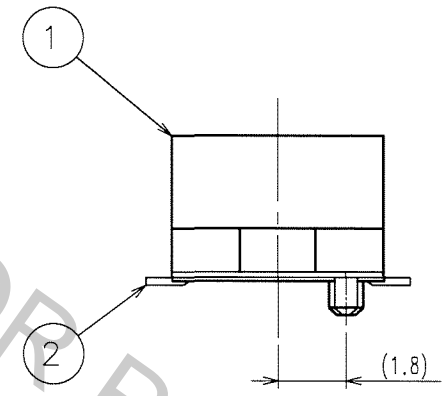
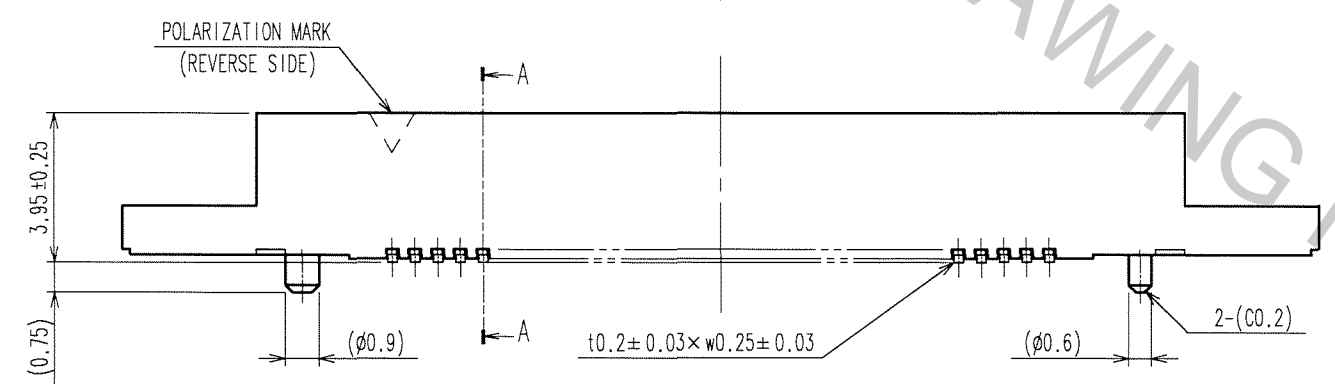
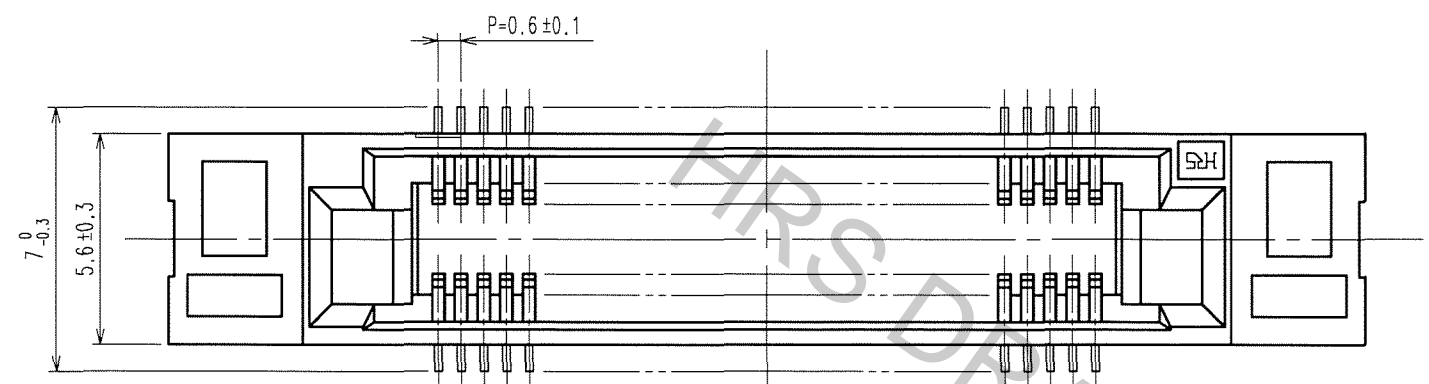

NOTE THE DIMENSIONS IN PARENTHESES ARE FOR REFERENCE.

TO
PCK

NO.	MATERIAL	FINISH, REMARKS	NO.	MATERIAL	FINISH, REMARKS
CODE NO. (OLD) CL			DRAWN	DESIGNED	CHECKED
			A.SUZUKAWA 06.10.27	H. Nakamura 06.10.27	H. Ogawa 06.10.27
				APPROVED	RELEASED
				H. Okawa 06.10.27	..
SCALE 5 : 1	DRAWING NO. EDC3-150961-25		PART NO. FX8C-60/60S11-SVJ(71)		
UNITS mm	HIROSE ELECTRIC CO., LTD		CODE NO. CL578-0901-7-71		2