



austriamicrosystems AG

is now

ams AG

The technical content of this austriamicrosystems datasheet is still valid.

Contact information:

Headquarters:

ams AG

Tobelbaderstrasse 30

8141 Unterpremstaetten, Austria

Tel: +43 (0) 3136 500 0

e-Mail: ams_sales@ams.com

Please visit our website at www.ams.com

Telephone Line Interface and Speakerphone Circuit AS2522B

DATA SHEET

Key Features

- Line/Speech circuit, DTMF dialer, FSK transmitter and tone ringer on a 32-pin CMOS-IC
- Enhanced voice switching
- Background noise monitoring
- DTMF tone generator
- FSK Transmitter V.23, BELL202, V.21, BELL 103
- Ringer tone programmable
- Tx- and Rx-gain programmable
- Digital volume control of Rx signals
- DC characteristic programmable
- Dual softclipping in handset mode
- Tx-softclipping in handsfree mode
- Common monitor amplifier for loudhearing, handsfree and ringing
- Supply voltage generation for external circuitry
- Automatic line loss compensation (LLC)
- Real and complex impedance selectable by external components
- Side tone adaptation selectable by external components
- Unique EMC performance
- Operating range from 15mA to 100mA (down to 5mA with reduced performance)
- Few external components

General Description

AS2522 is a CMOS integrated circuit that incorporates DC and AC line adaptation (DC-mask and synthesized AC-impedance of 1000Ω) as well as a speech circuit with softclipping, line loss compensation and Rx-volume control for handset and handsfree operation. It shall act as an a/b-line powered device, which is controlled by a CPU via a serial interface. Furthermore the AS2522 incorporates a DTMF, FSK transmitter, single tone and ringer tone generator.

AS2522 allows to use an off-the-shelf microprocessor without special blocks and functions for telephone applications. DTMF, FSK transmitter, single tone and ringer tone generator can be controlled via the serial interface as well as the gain settings in handset and handsfree mode.

Applications

Enhanced handsfree feature phones with CallerID and extended displays.

Package

Available in 32-pin TQFP

Block Diagram

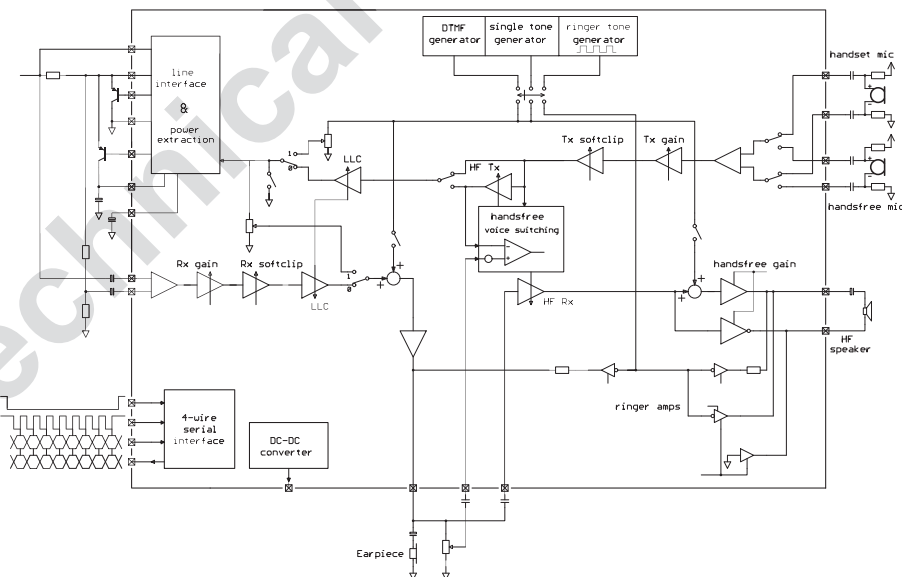

Pin description

| Pin # | Symbol | Function |
|-------|--------|--|
| 13 | LS | Line Current Sense Input Analog input for sensing the line current |
| 10 | LI | Line Input Analog input used for power extraction and line current sensing |
| 11 | RI | Receive Input Analog input for ac-separated receive signal |
| 7 | STB | Side Tone Balance Input Analog input for side tone cancellation network |
| 8 | CS | Current Shunt Control Output N-channel open drain output to control the external high power shunt transistor for synthesizing AC- and DC-impedance, modulation of line voltage and shorting the line during make periods of pulse dialing |
| 14 | CI | Complex Impedance Input Analog input pin for the capacitor to program a complex impedance |
| 12 | SS | Supply Source Control Output N-channel open drain output to control the external high power source transistor for supplying (Vpp) the loudspeaker amplifier in off-hook loudspeaking/handsfree mode |
| 9 | VSS | Voltage Source Source Negative Analog Power Supply |
| 18 | VDD | Voltage Drain Drain Positive Analog Power Supply |
| 19 | AGND | Analog Ground Special ground for the internal amplifiers |
| 6 | M1 | Microphone Input 1 Differential input for the handset microphone (electret) |
| 4 | M2 | Microphone Input 2 Differential input for the handset microphone (electret) |
| 5 | M3 | Microphone Input 3 Differential input for the handsfree microphone (electret) |
| 3 | M4 | Microphone Input 4 Differential input for the handsfree microphone (electret) |
| 17 | RO | Receive Output to Handset Output for driving a dynamic earpiece with an impedance from 150Ω to 300Ω |
| 31 | OSC | Oscillator Input Input for ceramic resonator 3.58MHz. |

| Pin # | Symbol | Function |
|----------|------------|--|
| 22 | VPP | Loudspeaker Power Supply High power supply for the output driver stage |
| 21 | CM | Converter Make Output This is an output for controlling the external switching converter. During ringing it converts the ring signal into a 4V supply voltage |
| 27 | xCS | Chip Select Chip select input of the serial interface. Internal pull-up resistor (100kOhm) |
| 29 | DI | Data Input Data input of the serial interface. Internal pull-up resistor (100kOhm) |
| 30 | CLK | Clock Clock input of the serial interface. Internal pull-up resistor (100kOhm) |
| 28 | DO | Data Output Data output of the serial interface. If xCS=1 DO is in HI-Z state |
| 24 23 | LO1 LO2 | Loudspeaker Output 1 and 2 Output pins for a 50Ω loudspeaker |
| 1 | FT1 | Analog input pin for connecting a capacitor for offset cancellation. |
| 2 | FT2 | Analog input pin for connecting a capacitor for offset cancellation. |
| 20 | CBN | Analog input pin for connecting a capacitor for background noise monitoring. |
| 15 | RECI | Analog input for the handsfree receive path. Should be connected to RO via coupling capacitor. |
| 16 | RECV | Analog input for receive voice switching path. |
| 25 | VSSA | Power supply pin for LS1-LS2 output amplifier. |
| 32 | VSSD | Voltage Source Source Digital Negative Digital Power Supply |
| 26 | VDDD | Voltage Drain Drain Digital Positive Digital Power Supply |

Detailed Block Diagram

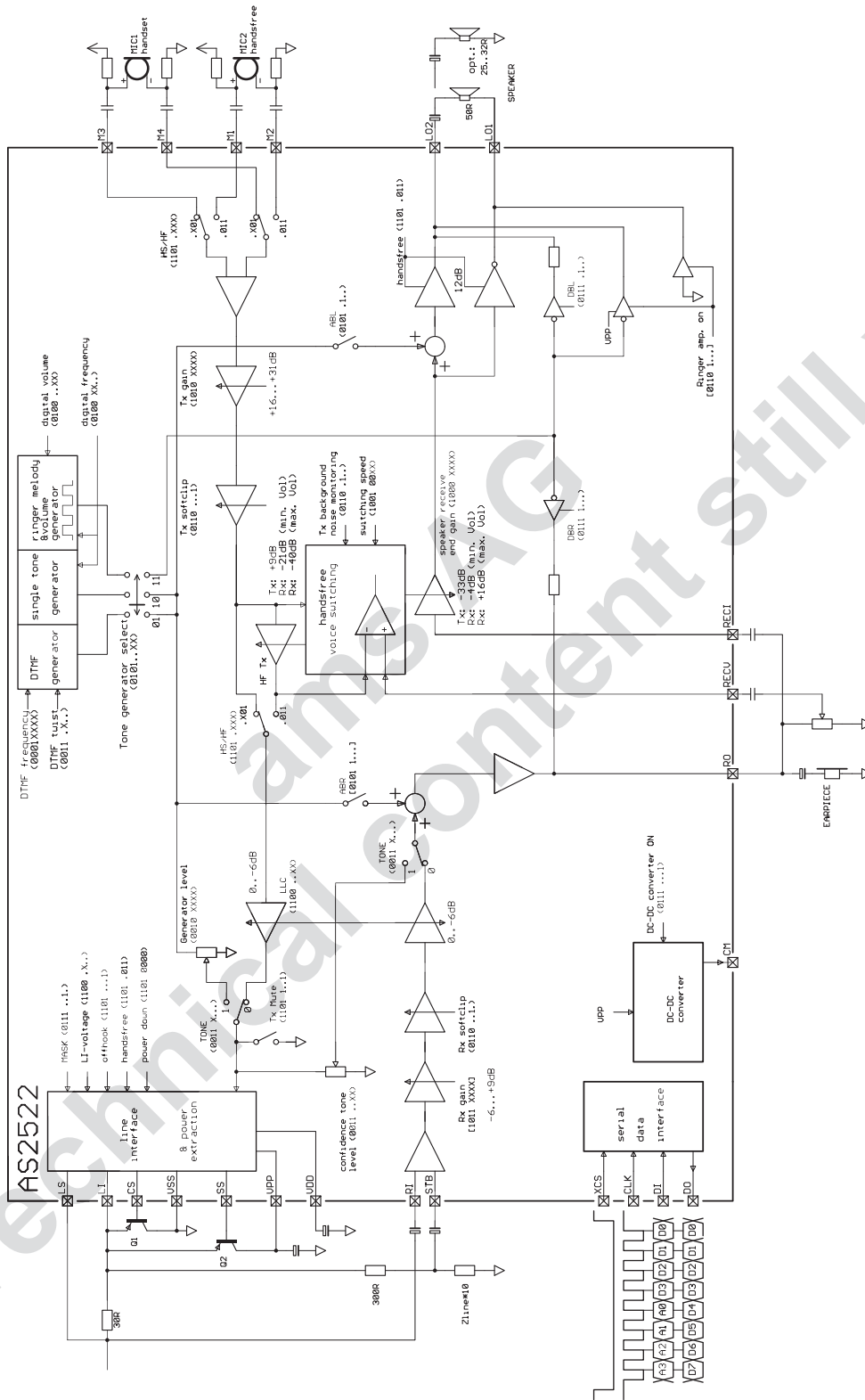

Functional Description

DC conditions

The normal operating mode is from 15mA to 100mA. An operating mode with reduced performance is from 5mA to 15mA. In the line hold range from 0mA to 5mA the device is in a power down mode.

The DC characteristic is determined by the voltage at LI-pin and a 30Ω resistor between LI- and LS-pin. It can be calculated by the following equation: $V_{LS} = V_{LI} + I_{Line} * 30\Omega$. V_{LI} can be programmed to be 3.5V or 4.5V.

2/4 wire conversion

AS2522 has a built-in dual Wheatstone bridge with one common ground. This provides a maximum of independence of AC-impedance and side tone from each other. One can adapt side tone without changing the AC-impedance.

AC-impedance

The AC-impedance of AS2522 is set to t.m. 1000Ω. With the external capacitor at CI-pin it can be programmed complex. With an external resistor of approx. 1.5kΩ connected to the LS-pin it can be programmed to 600Ω.

Side Tone

A good side tone cancellation can be achieved by using the following equation:

$$Z_{BAL}/Z_{LINE} = 10$$

Transmit path

The gain of the M1/M2 → LS is set to +37dB. This gain can be changed by programming from +30dB to +45dB in 1dB steps (Register *Txgain*). The input is differential with an impedance of 10kΩ. The soft clip circuit limits the output voltage at LS to 2Vp. There is LLC for this path.

The gain of the M3/M4 → LS is set to +46dB. This gain can be changed by programming from +39dB to +54dB in 1dB steps. The input is differential with an impedance of 10kΩ. The soft clip circuit limits the output voltage at LS to 2Vp. There is no LLC for this path.

Receive path

The gain of the LS → RO receive path is set to +1dB. This gain can be changed by programming from -6dB to +9dB in 1dB steps (Register *Rxgain*). The receive input is the differential signal of RI and STB. The soft clip circuit

limits the output voltage at RO to 1Vp. It prevents harsh distortion and acoustic shock. There is LLC for this path.

The gain of the LS → LO1/LO2 receive path is set to +29dB. This gain can be changed by programming from +22dB to -37dB in 1dB steps. The user can also change the gain via Register *VOL* (See section "Handsfree"). The receive input is the differential signal of RI and STB. The soft clip circuit limits the output voltage at LO1 of LO2 to 1Vp. It prevents harsh distortion and acoustic shock. There is optional LLC for this path.

Line Loss Compensation

The line loss compensation is programmable (Register *0x0C*). When it is activated, the transmit and receive gains for both I/O's are decreased by 6dB at line currents from 20mA to 50mA or from 45mA to 75mA.

Handsfree

The handsfree function allows voice communication without using the handset (full 2-way speaker phone). Two voice controlled attenuators prevent acoustic coupling between the loudspeaker and the microphone. The voice switching circuit has three states, namely idle, transmit or receive. In receive mode the attenuation of the receive path and the transmit path can be controlled by Register *VOL* between 0dB and -20dB. The following table shows how voice switching is controlled

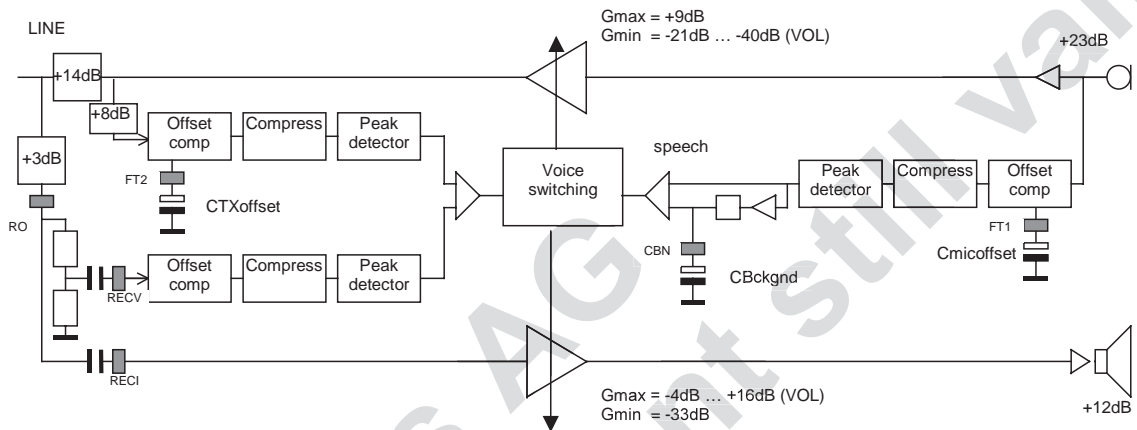
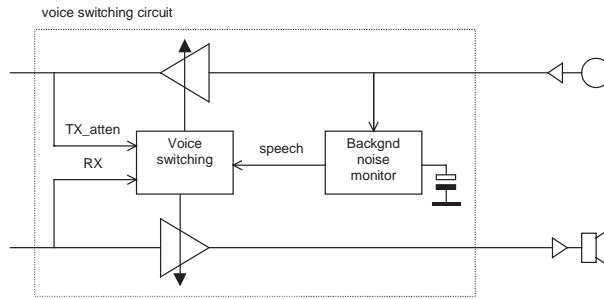

| Speech | Mode | Rx-gain | Tx-gain | Remark |
|---------------|------|----------|--------------|-----------------------------|
| Rx > Tx_atten | X | Receive | 0db to -20dB | adjustable with VOL-setting |
| Tx_atten > Rx | NO | Idle | -25 | middle position |
| Tx_atten > Rx | YES | Transmit | -50dB | independent of VOL-setting |

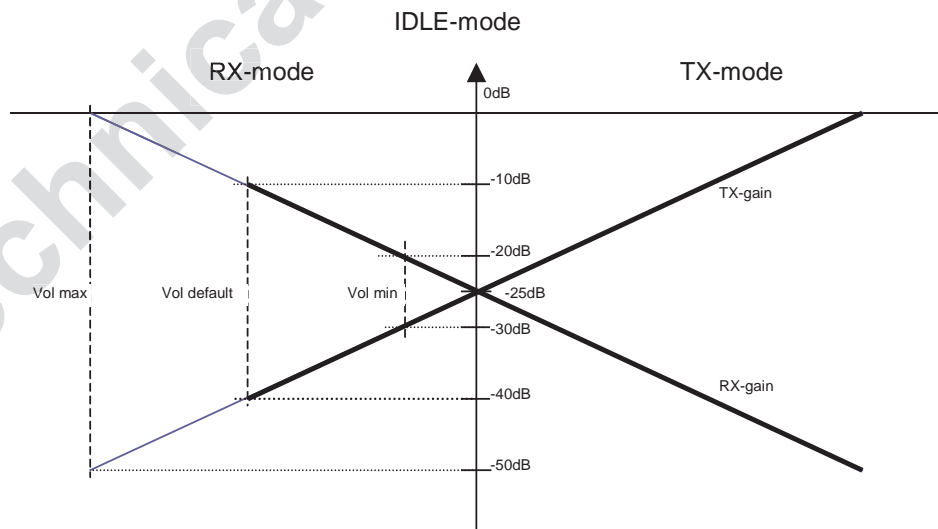

Serial Interface

Registers

The settings of the AS2522 are stored in 16 registers. Each register has 4 bit data width. Writing data into the AS2522 also causes the sending of the AS2522 status information on Pin D0. This information consists of the DC-current information (from the Line Loss Compensation circuit) and the status of the power-on reset circuit to test if AS2522 has already powered up.

| D7 | D6 | D5 | D4 | D3 | D2 | D1 | D0 |
|------|------|------|------|------|------|------|-----|
| LLC5 | LLC4 | LLC3 | LLC2 | LLC1 | LLC0 | xPOR | POR |

Power on reset information in Statusbits D1 and D0

| D1 | D0 | |
|----|----|------------------------|
| 0 | 0 | |
| 0 | 1 | AS2522 is in POR state |
| 1 | 0 | AS2522 is active |
| 1 | 1 | |

DC-current information in Statusbits D7 - D2

| D[7:2] | LLC-bit LO | LLC-bit HI |
|--------|------------|------------|
| 000000 | <20mA | <45mA |
| 000001 | 20-26mA | 45-51mA |
| 000011 | 26-32mA | 51-57mA |
| 000111 | 32-38mA | 57-63mA |
| 001111 | 38-44mA | 63-69mA |
| 011111 | 44-50mA | 69-75mA |
| 111111 | >50mA | >75mA |

Timing

The data format for writing to a register has the following form:

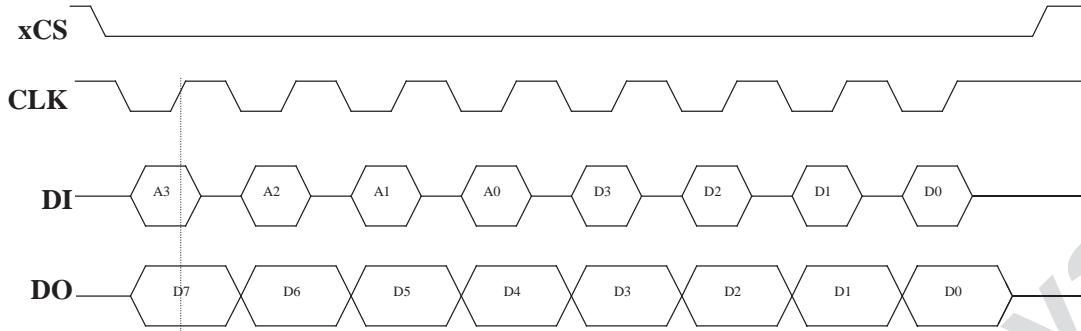

Note: The pins xCS,CLK,DI have internal pull-up resistors.

| Parameter | Symbol | MIN | TYP | MAX |
|--|--------|-------|------|-----|
| CLK Pulse width HIGH | t6 | 100ns | | |
| CLK Pulse width LOW | t5 | 100ns | | |
| xCS to first falling CLK-edge setup time | t1 | 50ns | | |
| CLK to DOUT delay | t2 | | 50ns | |
| DIN to CLK setup time | t3 | 50ns | | |
| DIN to CLK hold time | t4 | 50ns | | |

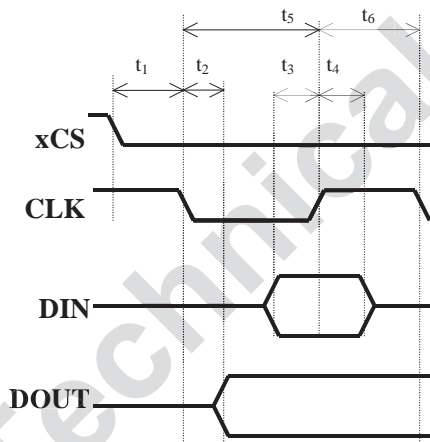

Serial interface Registers

The following table shows the content of the 16 control registers.

For a detailed description of the commands see Application note AN522.

| Address | Data | Control registers AS2522A, AS2522B | Default value after reset | | | | | | | | | | | | | | | | | | | | | | | | | | | | | | | | | | | | | | | | | | | | | | | | | | | | | | | | | | | | | | | | | | | | | | | | | | | | | | | | | | | | | |
|----------------------------------|----------------------------------|--|---------------------------|-------------------------|---------------------------------|---------------------|-------------------------|---------------------------------|--------|-------|-------|----------------|-----|--------|--------|-------|-------------------|-----|--------|--------|-------|--------------------|-----|--------|--------|-------|--------------------|------|--|--|--|--------------------|------|--|--|--|--------------------|--|--|--|--|------------------------|--|--|--|--|------------------------|--|--|--|--|-------------------|--|--|--|--|--------------------|--|--|--|--|------------------------|--|--|--|--|------------------------|--|--|--|--|--------------------|--|--|--|--|--------------------|--|--|--|--|------------------------|--|--|--|--|------------------------|------|
| A A A A 3 2 1 0 | D D D D 3 2 1 0 | | | | | | | | | | | | | | | | | | | | | | | | | | | | | | | | | | | | | | | | | | | | | | | | | | | | | | | | | | | | | | | | | | | | | | | | | | | | | | | | | | | | | | | |
| 0 0 0 0 | Nop | No operation. Write to this location to get AS2522-Status information without altering any other setting. | na | | | | | | | | | | | | | | | | | | | | | | | | | | | | | | | | | | | | | | | | | | | | | | | | | | | | | | | | | | | | | | | | | | | | | | | | | | | | | | | | | | | | | |
| 0 0 0 1 | DTMFpair | <p>Frequency select depending on Tone Generator mode</p> <p>DTMF-Generator mode: Single tone mode AS2522B ONLY AND FSK=1 (Addr 12):</p> <table border="1"> <thead> <tr> <th>HIGH Group</th> <th>LOW-Group</th> <th>Data</th> <th>f [3:0]</th> <th>Frequency</th> </tr> </thead> <tbody> <tr> <td>0 0</td> <td>1209Hz</td> <td>0 0</td> <td>697Hz</td> <td>0000 0Hz</td> </tr> <tr> <td>0 1</td> <td>1336Hz</td> <td>0 1</td> <td>770Hz</td> <td>0001 800Hz (ring)</td> </tr> <tr> <td>1 0</td> <td>1477Hz</td> <td>1 0</td> <td>852Hz</td> <td>0010 1067Hz (ring)</td> </tr> <tr> <td>1 1</td> <td>1633Hz</td> <td>1 1</td> <td>941Hz</td> <td>0011 1333Hz (ring)</td> </tr> <tr> <td></td> <td></td> <td></td> <td></td> <td>0100 1300Hz (V.23)</td> </tr> <tr> <td></td> <td></td> <td></td> <td></td> <td>0101 2100Hz (V.23)</td> </tr> <tr> <td></td> <td></td> <td></td> <td></td> <td>0110 1200Hz (Bell 202)</td> </tr> <tr> <td></td> <td></td> <td></td> <td></td> <td>0111 2200Hz (Bell 202)</td> </tr> <tr> <td></td> <td></td> <td></td> <td></td> <td>1000 980Hz (V.21)</td> </tr> <tr> <td></td> <td></td> <td></td> <td></td> <td>1001 1180Hz (V.21)</td> </tr> <tr> <td></td> <td></td> <td></td> <td></td> <td>1010 1070Hz (Bell 103)</td> </tr> <tr> <td></td> <td></td> <td></td> <td></td> <td>1011 1270Hz (Bell 103)</td> </tr> <tr> <td></td> <td></td> <td></td> <td></td> <td>1100 1650Hz (V.21)</td> </tr> <tr> <td></td> <td></td> <td></td> <td></td> <td>1101 1850Hz (V.21)</td> </tr> <tr> <td></td> <td></td> <td></td> <td></td> <td>1110 2025Hz (Bell 103)</td> </tr> <tr> <td></td> <td></td> <td></td> <td></td> <td>1111 2225Hz (Bell 103)</td> </tr> </tbody> </table> | HIGH Group | LOW-Group | Data | f [3:0] | Frequency | 0 0 | 1209Hz | 0 0 | 697Hz | 0000 0Hz | 0 1 | 1336Hz | 0 1 | 770Hz | 0001 800Hz (ring) | 1 0 | 1477Hz | 1 0 | 852Hz | 0010 1067Hz (ring) | 1 1 | 1633Hz | 1 1 | 941Hz | 0011 1333Hz (ring) | | | | | 0100 1300Hz (V.23) | | | | | 0101 2100Hz (V.23) | | | | | 0110 1200Hz (Bell 202) | | | | | 0111 2200Hz (Bell 202) | | | | | 1000 980Hz (V.21) | | | | | 1001 1180Hz (V.21) | | | | | 1010 1070Hz (Bell 103) | | | | | 1011 1270Hz (Bell 103) | | | | | 1100 1650Hz (V.21) | | | | | 1101 1850Hz (V.21) | | | | | 1110 2025Hz (Bell 103) | | | | | 1111 2225Hz (Bell 103) | 0000 |
| HIGH Group | LOW-Group | Data | f [3:0] | Frequency | | | | | | | | | | | | | | | | | | | | | | | | | | | | | | | | | | | | | | | | | | | | | | | | | | | | | | | | | | | | | | | | | | | | | | | | | | | | | | | | | | | | |
| 0 0 | 1209Hz | 0 0 | 697Hz | 0000 0Hz | | | | | | | | | | | | | | | | | | | | | | | | | | | | | | | | | | | | | | | | | | | | | | | | | | | | | | | | | | | | | | | | | | | | | | | | | | | | | | | | | | | | |
| 0 1 | 1336Hz | 0 1 | 770Hz | 0001 800Hz (ring) | | | | | | | | | | | | | | | | | | | | | | | | | | | | | | | | | | | | | | | | | | | | | | | | | | | | | | | | | | | | | | | | | | | | | | | | | | | | | | | | | | | | |
| 1 0 | 1477Hz | 1 0 | 852Hz | 0010 1067Hz (ring) | | | | | | | | | | | | | | | | | | | | | | | | | | | | | | | | | | | | | | | | | | | | | | | | | | | | | | | | | | | | | | | | | | | | | | | | | | | | | | | | | | | | |
| 1 1 | 1633Hz | 1 1 | 941Hz | 0011 1333Hz (ring) | | | | | | | | | | | | | | | | | | | | | | | | | | | | | | | | | | | | | | | | | | | | | | | | | | | | | | | | | | | | | | | | | | | | | | | | | | | | | | | | | | | | |
| | | | | 0100 1300Hz (V.23) | | | | | | | | | | | | | | | | | | | | | | | | | | | | | | | | | | | | | | | | | | | | | | | | | | | | | | | | | | | | | | | | | | | | | | | | | | | | | | | | | | | | |
| | | | | 0101 2100Hz (V.23) | | | | | | | | | | | | | | | | | | | | | | | | | | | | | | | | | | | | | | | | | | | | | | | | | | | | | | | | | | | | | | | | | | | | | | | | | | | | | | | | | | | | |
| | | | | 0110 1200Hz (Bell 202) | | | | | | | | | | | | | | | | | | | | | | | | | | | | | | | | | | | | | | | | | | | | | | | | | | | | | | | | | | | | | | | | | | | | | | | | | | | | | | | | | | | | |
| | | | | 0111 2200Hz (Bell 202) | | | | | | | | | | | | | | | | | | | | | | | | | | | | | | | | | | | | | | | | | | | | | | | | | | | | | | | | | | | | | | | | | | | | | | | | | | | | | | | | | | | | |
| | | | | 1000 980Hz (V.21) | | | | | | | | | | | | | | | | | | | | | | | | | | | | | | | | | | | | | | | | | | | | | | | | | | | | | | | | | | | | | | | | | | | | | | | | | | | | | | | | | | | | |
| | | | | 1001 1180Hz (V.21) | | | | | | | | | | | | | | | | | | | | | | | | | | | | | | | | | | | | | | | | | | | | | | | | | | | | | | | | | | | | | | | | | | | | | | | | | | | | | | | | | | | | |
| | | | | 1010 1070Hz (Bell 103) | | | | | | | | | | | | | | | | | | | | | | | | | | | | | | | | | | | | | | | | | | | | | | | | | | | | | | | | | | | | | | | | | | | | | | | | | | | | | | | | | | | | |
| | | | | 1011 1270Hz (Bell 103) | | | | | | | | | | | | | | | | | | | | | | | | | | | | | | | | | | | | | | | | | | | | | | | | | | | | | | | | | | | | | | | | | | | | | | | | | | | | | | | | | | | | |
| | | | | 1100 1650Hz (V.21) | | | | | | | | | | | | | | | | | | | | | | | | | | | | | | | | | | | | | | | | | | | | | | | | | | | | | | | | | | | | | | | | | | | | | | | | | | | | | | | | | | | | |
| | | | | 1101 1850Hz (V.21) | | | | | | | | | | | | | | | | | | | | | | | | | | | | | | | | | | | | | | | | | | | | | | | | | | | | | | | | | | | | | | | | | | | | | | | | | | | | | | | | | | | | |
| | | | | 1110 2025Hz (Bell 103) | | | | | | | | | | | | | | | | | | | | | | | | | | | | | | | | | | | | | | | | | | | | | | | | | | | | | | | | | | | | | | | | | | | | | | | | | | | | | | | | | | | | |
| | | | | 1111 2225Hz (Bell 103) | | | | | | | | | | | | | | | | | | | | | | | | | | | | | | | | | | | | | | | | | | | | | | | | | | | | | | | | | | | | | | | | | | | | | | | | | | | | | | | | | | | | |
| 0 0 1 0 | DTMFLevel | DTMF-Level 13 steps, 1dB stepsize | 1100 | | | | | | | | | | | | | | | | | | | | | | | | | | | | | | | | | | | | | | | | | | | | | | | | | | | | | | | | | | | | | | | | | | | | | | | | | | | | | | | | | | | | | |
| 0 0 1 1 | x x x x | <p>Data DTMF-level LOW GROUP at pin LS</p> <p>0x0 -16dBm : 0xC -4dBm</p> | 0101 | | | | | | | | | | | | | | | | | | | | | | | | | | | | | | | | | | | | | | | | | | | | | | | | | | | | | | | | | | | | | | | | | | | | | | | | | | | | | | | | | | | | | |
| 0 1 0 0 | Tone preemph CT1 CT0 | <p>DTMF-settings</p> <p>Tone: DTMF-signal path 0...OFF, 1...ON preemph: DTMF-preemphsis 0...2.2dB, 1...3.2dB CT1 CT0: @RO @LO1/LO2</p> <table border="1"> <thead> <tr> <th></th> <th></th> <th>-36dB</th> <th>-15dB</th> <th>DTMF-confidence level</th> </tr> </thead> <tbody> <tr> <td>0</td> <td>0</td> <td>-36dB</td> <td>-15dB</td> <td>rel. to pin LS</td> </tr> <tr> <td>0</td> <td>1</td> <td>-30dB</td> <td>-9dB</td> <td></td> </tr> <tr> <td>1</td> <td>0</td> <td>-24dB</td> <td>-3dB</td> <td></td> </tr> <tr> <td>1</td> <td>1</td> <td>-18dB</td> <td>+3dB</td> <td></td> </tr> </tbody> </table> | | | -36dB | -15dB | DTMF-confidence level | 0 | 0 | -36dB | -15dB | rel. to pin LS | 0 | 1 | -30dB | -9dB | | 1 | 0 | -24dB | -3dB | | 1 | 1 | -18dB | +3dB | | 0000 | | | | | | | | | | | | | | | | | | | | | | | | | | | | | | | | | | | | | | | | | | | | | | | | | | | | | | | | | | | | |
| | | -36dB | -15dB | DTMF-confidence level | | | | | | | | | | | | | | | | | | | | | | | | | | | | | | | | | | | | | | | | | | | | | | | | | | | | | | | | | | | | | | | | | | | | | | | | | | | | | | | | | | | | |
| 0 | 0 | -36dB | -15dB | rel. to pin LS | | | | | | | | | | | | | | | | | | | | | | | | | | | | | | | | | | | | | | | | | | | | | | | | | | | | | | | | | | | | | | | | | | | | | | | | | | | | | | | | | | | | |
| 0 | 1 | -30dB | -9dB | | | | | | | | | | | | | | | | | | | | | | | | | | | | | | | | | | | | | | | | | | | | | | | | | | | | | | | | | | | | | | | | | | | | | | | | | | | | | | | | | | | | | |
| 1 | 0 | -24dB | -3dB | | | | | | | | | | | | | | | | | | | | | | | | | | | | | | | | | | | | | | | | | | | | | | | | | | | | | | | | | | | | | | | | | | | | | | | | | | | | | | | | | | | | | |
| 1 | 1 | -18dB | +3dB | | | | | | | | | | | | | | | | | | | | | | | | | | | | | | | | | | | | | | | | | | | | | | | | | | | | | | | | | | | | | | | | | | | | | | | | | | | | | | | | | | | | | |
| 0 1 0 1 | freq1 frequ0 V1 V0 | <p>Single Tone frequencies if FSK=0 (Addr. 12) and RING/Beep Volume [4]</p> <table border="1"> <thead> <tr> <th>freq1</th> <th>frequ0</th> <th>V1</th> <th>V0</th> <th>RING volume</th> </tr> </thead> <tbody> <tr> <td>0</td> <td>0</td> <td>800Hz</td> <td>0</td> <td>0 -17.5dB</td> </tr> <tr> <td>0</td> <td>1</td> <td>1067Hz</td> <td>0</td> <td>1 -11.5dB</td> </tr> <tr> <td>1</td> <td>0</td> <td>1333Hz</td> <td>1</td> <td>0 -5.5dB</td> </tr> <tr> <td>1</td> <td>1</td> <td>1333Hz</td> <td>1</td> <td>1 0dB</td> </tr> </tbody> </table> | freq1 | frequ0 | V1 | V0 | RING volume | 0 | 0 | 800Hz | 0 | 0 -17.5dB | 0 | 1 | 1067Hz | 0 | 1 -11.5dB | 1 | 0 | 1333Hz | 1 | 0 -5.5dB | 1 | 1 | 1333Hz | 1 | 1 0dB | 0000 | | | | | | | | | | | | | | | | | | | | | | | | | | | | | | | | | | | | | | | | | | | | | | | | | | | | | | | | | | | | |
| freq1 | frequ0 | V1 | V0 | RING volume | | | | | | | | | | | | | | | | | | | | | | | | | | | | | | | | | | | | | | | | | | | | | | | | | | | | | | | | | | | | | | | | | | | | | | | | | | | | | | | | | | | | |
| 0 | 0 | 800Hz | 0 | 0 -17.5dB | | | | | | | | | | | | | | | | | | | | | | | | | | | | | | | | | | | | | | | | | | | | | | | | | | | | | | | | | | | | | | | | | | | | | | | | | | | | | | | | | | | | |
| 0 | 1 | 1067Hz | 0 | 1 -11.5dB | | | | | | | | | | | | | | | | | | | | | | | | | | | | | | | | | | | | | | | | | | | | | | | | | | | | | | | | | | | | | | | | | | | | | | | | | | | | | | | | | | | | |
| 1 | 0 | 1333Hz | 1 | 0 -5.5dB | | | | | | | | | | | | | | | | | | | | | | | | | | | | | | | | | | | | | | | | | | | | | | | | | | | | | | | | | | | | | | | | | | | | | | | | | | | | | | | | | | | | |
| 1 | 1 | 1333Hz | 1 | 1 0dB | | | | | | | | | | | | | | | | | | | | | | | | | | | | | | | | | | | | | | | | | | | | | | | | | | | | | | | | | | | | | | | | | | | | | | | | | | | | | | | | | | | | |
| 0 1 1 0 | Burs Burl M1 M0 | <p>Tone Generator mode, single tone path</p> <p>BURS: Analog tone at RO 0...OFF, 1...ON BURL: Analog tone at LO1/LO2 0...OFF, 1...ON M1 M0: Tone generator mode select</p> <table border="1"> <thead> <tr> <th></th> <th></th> <th>Tone generator OFF</th> <th>DTMF generator mode</th> <th>Single tone Analog mode</th> <th>Single tone Digital mode (RING)</th> </tr> </thead> <tbody> <tr> <td>0</td> <td>0</td> <td></td> <td></td> <td></td> <td></td> </tr> <tr> <td>0</td> <td>1</td> <td></td> <td></td> <td></td> <td></td> </tr> <tr> <td>1</td> <td>0</td> <td></td> <td></td> <td></td> <td></td> </tr> <tr> <td>1</td> <td>1</td> <td></td> <td></td> <td></td> <td></td> </tr> </tbody> </table> | | | Tone generator OFF | DTMF generator mode | Single tone Analog mode | Single tone Digital mode (RING) | 0 | 0 | | | | | 0 | 1 | | | | | 1 | 0 | | | | | 1 | 1 | | | | | 0000 | | | | | | | | | | | | | | | | | | | | | | | | | | | | | | | | | | | | | | | | | | | | | | | | | | | | | | | |
| | | Tone generator OFF | DTMF generator mode | Single tone Analog mode | Single tone Digital mode (RING) | | | | | | | | | | | | | | | | | | | | | | | | | | | | | | | | | | | | | | | | | | | | | | | | | | | | | | | | | | | | | | | | | | | | | | | | | | | | | | | | | | | |
| 0 | 0 | | | | | | | | | | | | | | | | | | | | | | | | | | | | | | | | | | | | | | | | | | | | | | | | | | | | | | | | | | | | | | | | | | | | | | | | | | | | | | | | | | | | | | | |
| 0 | 1 | | | | | | | | | | | | | | | | | | | | | | | | | | | | | | | | | | | | | | | | | | | | | | | | | | | | | | | | | | | | | | | | | | | | | | | | | | | | | | | | | | | | | | | |
| 1 | 0 | | | | | | | | | | | | | | | | | | | | | | | | | | | | | | | | | | | | | | | | | | | | | | | | | | | | | | | | | | | | | | | | | | | | | | | | | | | | | | | | | | | | | | | |
| 1 | 1 | | | | | | | | | | | | | | | | | | | | | | | | | | | | | | | | | | | | | | | | | | | | | | | | | | | | | | | | | | | | | | | | | | | | | | | | | | | | | | | | | | | | | | | |
| 0 1 1 1 | ring Bnon Soft-RX Soft-TX | <p>Softclip-settings, Noise monitoring</p> <p>RING: RING-path 0...OFF, 1...ON BNON: Noise monitor 0...OFF, 1...ON SOFTRX: Softclip RX 0...OFF, 1...ON SOFTTX: Softclip TX 0...OFF, 1...ON</p> | 0000 | | | | | | | | | | | | | | | | | | | | | | | | | | | | | | | | | | | | | | | | | | | | | | | | | | | | | | | | | | | | | | | | | | | | | | | | | | | | | | | | | | | | | |
| 0 1 1 1 | ldbr ldbl Mask DC/DC | <p>DC/DC-Converter ON/OFF,Mask</p> <p>ldbr: Digital tone at RO 0...OFF, 1...ON ldbl: Digital tone at LO1/LO2 0...OFF, 1...ON MASK: Mask function 0...OFF, 1...ON DC/DC: DC/DC-converter 0...OFF, 1...ON</p> | 0000 | | | | | | | | | | | | | | | | | | | | | | | | | | | | | | | | | | | | | | | | | | | | | | | | | | | | | | | | | | | | | | | | | | | | | | | | | | | | | | | | | | | | | |

| Address | Data | Control registers AS2522A, AS2522B | Default value after reset |
|----------------------------------|--|---|---------------------------|
| A A A A 3 2 1 0 | D D D D 3 2 1 0 | | |
| 1 0 0 0 | 16 gains | Handsfree receive endgain Data RXgain TXgain 0x0 -20dB -30dB Min. receive volume : : 0xF 0dB -50dB Max. receive volume | 0111 |
| 1 0 0 1 | x x x x off1 off0 Hfs1 Hfs0 | Handsfree switching characteristic off1 off0 : BGN-offset 0 0 120mV 0 1 180mV 1 0 240mV 1 1 300mV Hfs1 Hfs0 : Speed of voice switching 0 0 max speed 0 1 1 0 1 1 min speed | 1000 |
| 1 0 1 0 | 16 gains | Transmit gain [16], 16 steps, 1dB stepsize Data HS-mode HF-mode 0x0 30dB 39dB : : 0xF 45dB 54dB | 0111 |
| 1 0 1 1 | 16 gains | Receive gain [16], 16 steps, 1dB stepsize Data HS-mode HF-mode 0x0 -6dB 22dB : : 0xF +9dB 37dB | 0111 |
| 1 1 0 0 | x x x x FSK LIV Llc1 Llc0 | FSK-mode, LLC[2], LI-Voltage AS2522B: FSK: Frequency select in single tone mode AS2522B ONLY FSK: 0 Single Tone frequencies are read from Addr. 4: frequ1, frequ0 1 Single Tone frequencies are read from Addr. 1: f4,f3,f2,f1 AS2522A FSK: For factory test only ! LIV: Voltage at pin LI 0...3.5V, 1...4.5V LLC1 LLC0: Line loss compensation setting 0 0 20mA-50mA 0 1 NO Line loss compensation 1 0 45-75mA 1 1 NO Line loss compensation | 0111 |
| 1 1 0 1 | x x x x Mute Lh Hf His | Mute, Lh, Hf, Hook Switch Mute: Mute transmit 0...OFF, 1...ON His Hf Lh 0 x x On Hook 1 0 0 Off Hook, Handset mode 1 1 0 Off Hook, Handfree mode 1 1 1 Off Hook, Loudhearing mode | 0000 |
| 1 1 1 0 | x x x x Krat5 Test3 Test2 Test1 | Krat5,Test3,Test2,Test1: For factory test only ! | 0000 |
| 1 1 1 1 | x x x x | Reset to defaults | na |

Electrical characteristics

Electrical characteristics are measured with the Test Circuit application. Typical mean values will not be tested.

Absolute maximum ratings

| | |
|---|------------------------|
| Positive Supply Voltage | -0.3V ≤ VDD ≤ 7V |
| Input Current | +/- 25mA |
| Input Voltage (LS) | -0.3V ≤ Vin ≤ 12V |
| Input Voltage (LI, CS) | -0.3V ≤ Vin ≤ 8V |
| Input Voltage (STB, RI) | -2V ≤ Vin ≤ VDD+0.3V |
| Digital Input Voltage | -0.3V ≤ Vin ≤ VDD+0.3V |
| Electrostatic Discharge (HBM 1.5kΩ-100pF) | +/- 1000V |
| Storage Temperature | -65°C to +125°C |

Recommended operating conditions

| | |
|---------------------------------------|----------------|
| Supply Voltage (generated internally) | 3V ≤ VDD ≤ 5V |
| Operating Temperature | -25°C to +70°C |

DC characteristics

I_{Line}=15mA w/o operation of any additional external circuitry, unless other specified

| Symbol | Parameter | Conditions | Min | Type | Max | Units | Test |
|------------------|--|----------------------------------|------------|------------|------------|--------|--------|
| I _{DD5} | Operating Current | Speech Mode | | 3 | 6 | mA | Y |
| I _{DDH} | Operating Current | Handsfree Mode | | 7 | 10 | mA | Y |
| V _{LI} | Line Voltage L _I Volt=0 Line Voltage L _I Volt=1 | 15mA ≤ I _{LINE} ≤ 100mA | 3.2 4.2 | 3.5 4.5 | 3.8 4.8 | V V | Y Y |
| I _{OL} | Output Current, Sink CS,SS | V _{OL} =0.4V | | 1 | | mA | N |

Transmit characteristics

I_{Line}=15mA f=800Hz, default settings unless other specified

| Symbol | Parameter | Conditions | Min | Type | Max | Units | Test |
|----------------------|--------------------------------------|---|-----|-------|-----|------------------|------|
| AM1/2TX | Transmit Gain M1/M2 → LS | Z _{AC(syn)} =1000Ω | 35 | +36.5 | 38 | dB | Y |
| AM3/4TX | Transmit Gain M3/M4 → LS | Z _{AC(syn)} =1000Ω | 43 | +45.0 | 47 | dB | Y |
| ΔATX | Variation with frequency | f = 500Hz ... 3.4kHz | | ±0.8 | | dB | N |
| AVRM12 | Control range M1/M2 → LS | 16 steps | | -7/+8 | | dBr | N |
| AVRM34 | Control range M2/M4 → LS | 16 steps | | -7/+8 | | dBr | N |
| THD | Distortion | V _{LS} =0.25V _{RMS} | | | 2 | % | Y |
| VAGC1 | Soft Clip Level M1/M2 → LS at LS | | | 2 | | VP | N |
| VAGC2 | Soft Clip Level M3/M4 → LS at LS | | | 2 | | VP | N |
| ASCO | Soft Clip Overdrive M1/M2 - M3/M4 | | | 20 | | dB | N |
| t _{attack} | Attack time | | | 70 | | us/6dB | N |
| t _{decay} | Decay time | | | 100 | | ms/6dB | N |
| Z _{IN-M1/2} | Input Impedance M1/M2 | | | 10 | | kΩ | N |
| Z _{IN-M3/4} | Input Impedance M3/M4 | | | 10 | | kΩ | N |
| V _{INmax} | Input Voltage Range M1/2 - M3/4 | differential | | ±1 | | V _p | N |
| V _{NO} | Noise Output Voltage LS | T _{AMP} =25°C Handset mode Gain = 36.5dB | | | -72 | dB _{mp} | Y |
| AMUTE | Mute Attenuation | Mute activated | 60 | | | dB | Y |

Receive characteristics

I_{Line}=15mA f=800Hz, default settings unless other specified

| Symbol | Parameter | Conditions | Min | Type | Max | Units | Test |
|-------------------|---|-------------------------------|-----|----------|-----|------------|------|
| ARO | Receive Gain LS → RO | ZAC(syn)=1000Ω Vol default | -2 | -0.5 | 1 | dB | Y |
| ALO12 | Receive Gain LS → LO1/LO2 | ZAC(syn)=1000Ω Vol maximum | +28 | +29.0 | +31 | dB | Y |
| ΔARX | Variation with frequency | f=500Hz to 3.4kHz | | ±0.8 | | dB | N |
| AVRRO | Control range LS → RO | 16 steps | | -7/+8 | | dBr | N |
| AVRLS | Control range LS → LS1/LS2 | 16 steps | | -7/+8 | | dBr | N |
| THDLS | Distortion LS1/LS2 | V _{LS} =0.25VRMS | | | 5 | % | Y |
| THDRO | Distortion RO | V _{LS} =0.25VRMS | | | 2 | % | Y |
| VUFC | Unwanted Freq. Cmp. | f = 200 ... 20kHz | | | -60 | dBm | Y |
| VAGCRO | Soft Clip Level RO | | | 1 | | VP | N |
| VAGCLS | Soft Clip Level LS1/2 | | | 2 | | VP | N |
| ASCLS | Soft Clip Overdrive LS1/2 | | | 10 | | dB | N |
| tattack | Attack time | | | 70 | | us/6dB | N |
| tdecay | Decay time | | | 100 | | ms/6dB | N |
| VNO | Noise Output Voltage RO | TAMP=25°C Gain = 3dB | | | -72 | dBmp | Y |
| ZIN-RI VINmax | Input Imp. RI Input Voltage Range RI | | | 8 ±2 | | kΩ Vp | N |
| ZIN-STB VINmax | Input Imp. STB Input Volt. Range STB | | | 80 ±2 | | kΩ Vp | N |
| ST | Side tone | V _{RI} <=0.25VRMS | 26 | | | dB | Y |
| RL ΔZAC/°C | Return Loss Temp. Variation | ZAC(syn)=1000Ω | 18 | 0.5 | | dB Ω/°C | Y |

DTMF characteristics

I_{Line}=15mA w/o operation of any additional external circuitry, unless other specified, default settings

| Symbol | Parameter | Conditions | Min | Type | Max | Units | Test |
|-------------------|----------------------------------|----------------------------------|-----|--------|-----|-------|------|
| VMFlow | Tone level low group at LS | Default | -7 | -6 | -5 | dBm | Y |
| MFRange | DTMF level range low group at LS | 13 steps Prg. in Service mode | | -18/-6 | | dBm | N |
| Δ VL-H | Preemphasis L-H | Preemphasis=1 | 2.7 | 3.2 | 3.7 | dB | Y |
| UFC | Unwanted frequency components | 300 Hz - 4.3kHz | | | -40 | dBm | Y |
| | | 4.3kHz - 7kHz | | | -46 | dBm | Y |
| | | 7kHz - 10kHz | | | -52 | dBm | Y |
| | | 10kHz - 14kHz | | | -58 | dBm | Y |
| | | 14kHz - 28.5kHz | | | -70 | dBm | Y |
| | | 28.5kHz - 40kHz | | | -80 | dBm | Y |
| Δ f | Frequency deviation | | | | 1.2 | % | Y |
| V _{CT-H} | Comfort tone handset | Rel to LS | | -36 | | dBr | N |
| | | programmable in service mode | | -30 | | dBr | N |
| | | | | -24 | | dBr | N |
| | | | | -18 | | dBr | N |
| V _{CT-L} | Comfort tone Loudspeaker | Rel to LS | | -15 | | dBr | N |
| | | programmable in service mode | | -9 | | dBr | N |
| | | | | -3 | | dBr | N |
| | | | | +3 | | dBr | N |

Ringer

| Symbol | Parameter | Conditions | Min | Type | Max | Units | Test |
|--------|--------------|------------|------|------|------|-------|------|
| F0 | Frequency 0 | | | 0 | | Hz | N |
| F1 | Frequency 1 | | 770 | 800 | 830 | Hz | Y |
| F2 | Frequency 2 | | 1025 | 1067 | 1110 | Hz | Y |
| F3 | Frequency 3 | | 1280 | 1333 | 1385 | Hz | Y |
| F4 | Frequency 4 | | | 1300 | | Hz | N |
| F5 | Frequency 5 | | | 2100 | | Hz | N |
| F6 | Frequency 6 | | | 1200 | | Hz | N |
| F7 | Frequency 7 | | | 2200 | | Hz | N |
| F8 | Frequency 8 | | | 980 | | Hz | N |
| F9 | Frequency 9 | | | 1180 | | Hz | N |
| F10 | Frequency 10 | | | 1070 | | Hz | N |
| F11 | Frequency 11 | | | 1270 | | Hz | N |
| F12 | Frequency 12 | | | 1650 | | Hz | N |
| F13 | Frequency 13 | | | 1850 | | Hz | N |
| F14 | Frequency 14 | | | 2025 | | Hz | N |
| F15 | Frequency 15 | | | 2225 | | Hz | N |

Miscellaneous

| Symbol | Parameter | Conditions | Min | Type | Max | Units | Test |
|--------|-------------------------|--------------|-----|------|-----|-------|------|
| VPARO | Pacifier level at RO | RL = 150 Ohm | | 30 | | mVpp | N |
| VPALS | Pacifier level at LS1/2 | RL = 50 Ohm | | 100 | | mVpp | N |

Test circuit

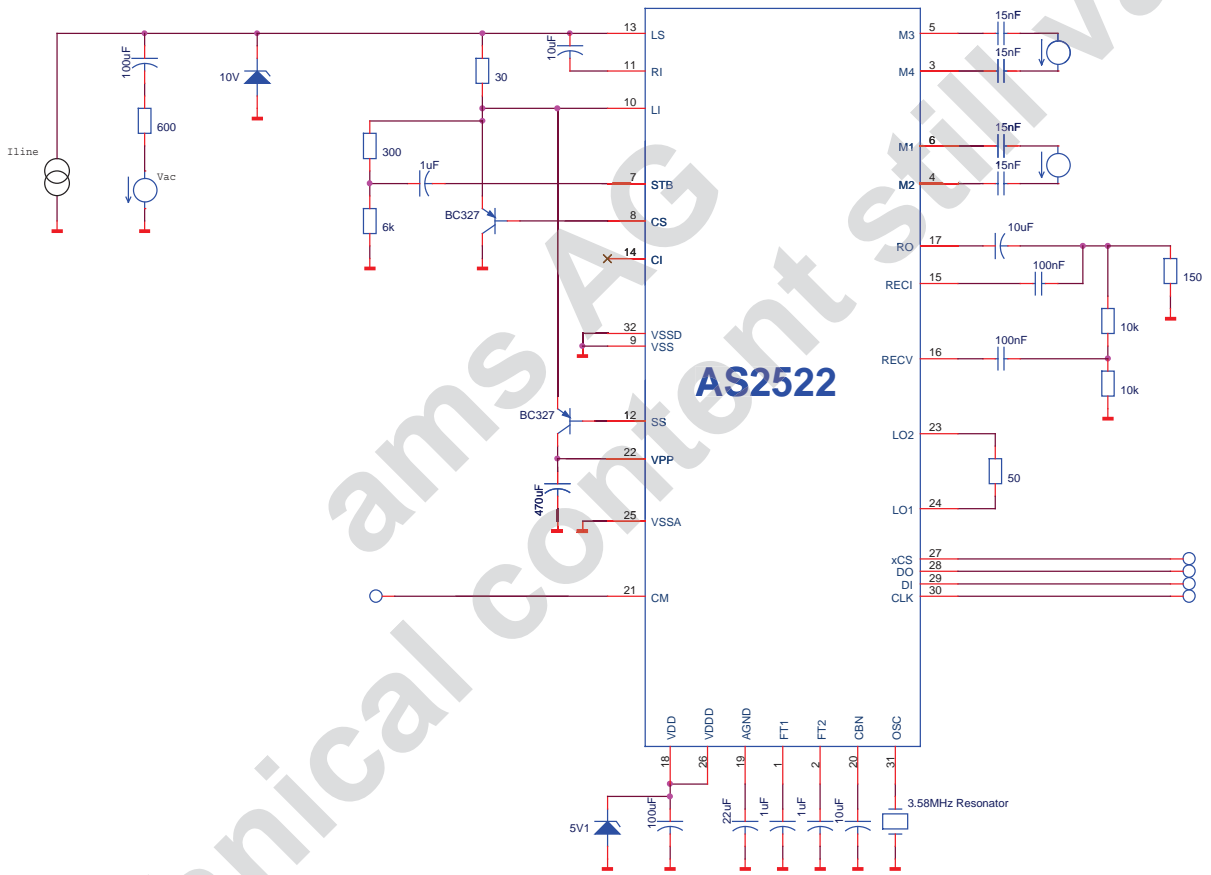

Typical application

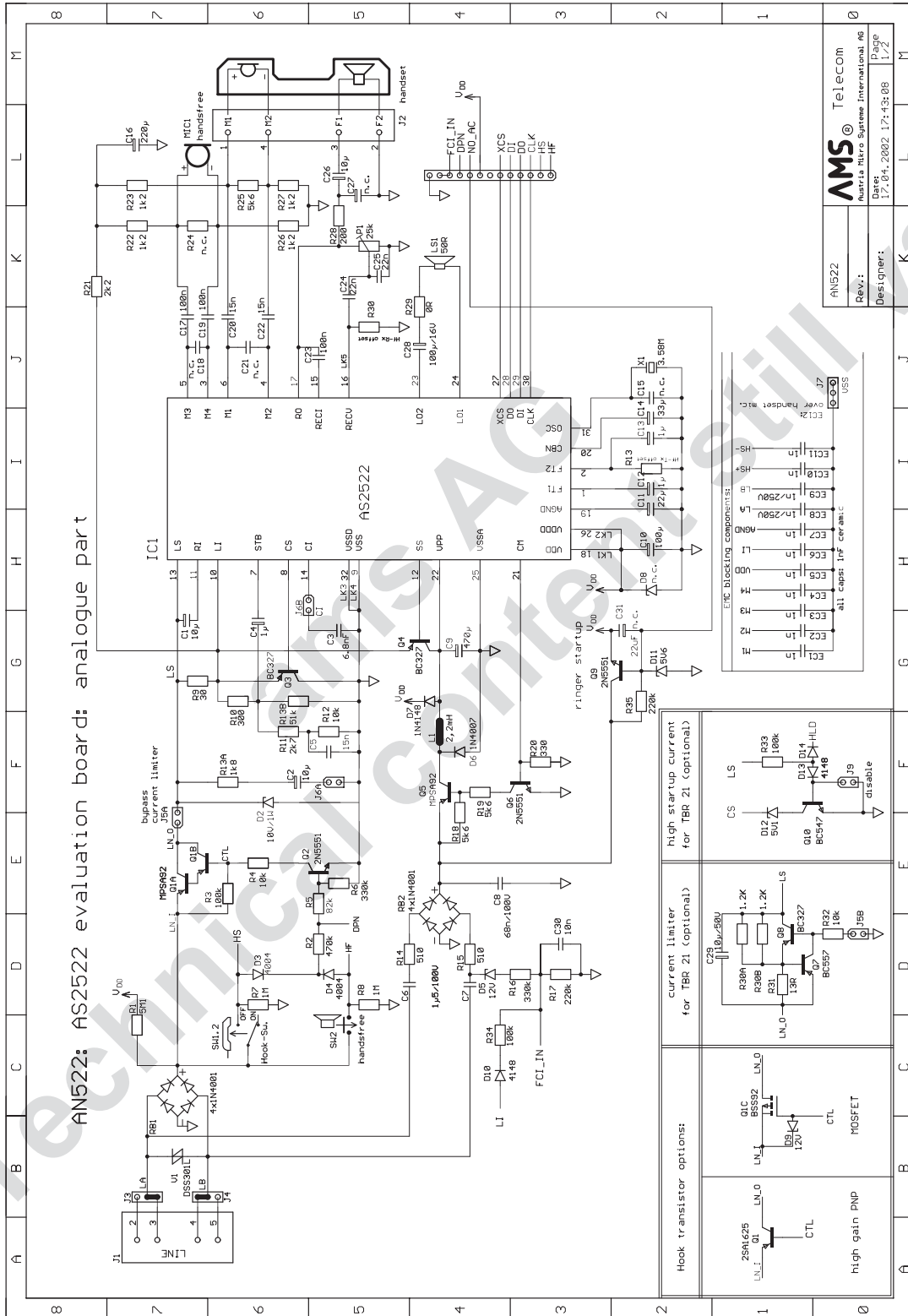

| | | |
|-----------|-------------------------------|-----------|
| AN522 | AMS | Telecom |
| Rev.: 1.2 | Designer: 17-04-2002 17:43:08 | Page: 1/2 |

Bonding Diagram

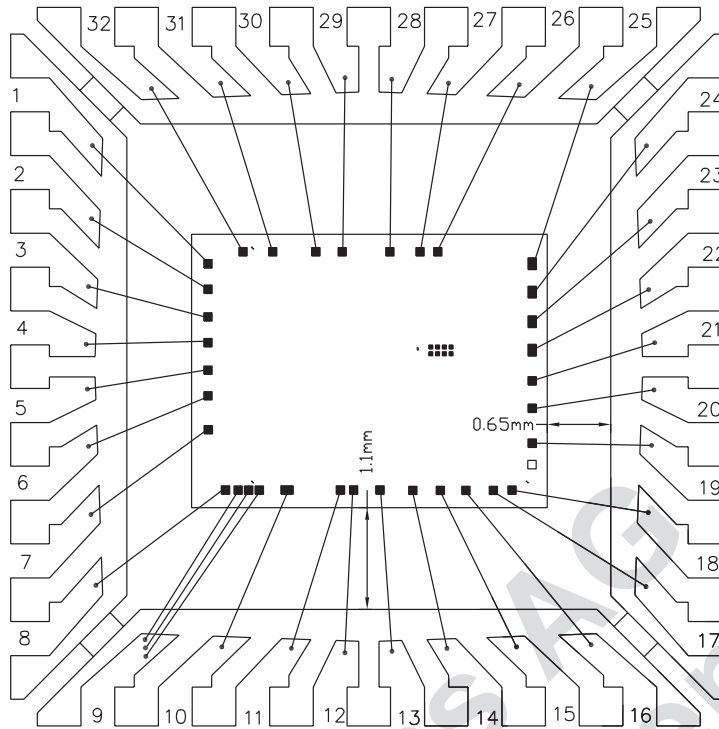

32 Lead 7x7mm TQFP dimensions

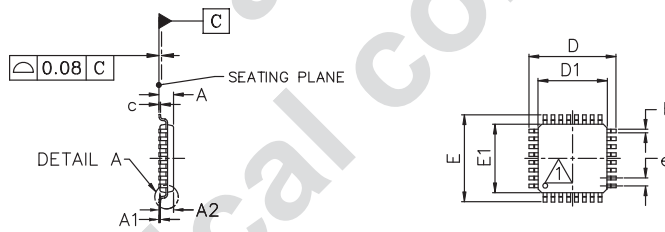

| SYMBOL | MILLIMETER | | | INCH | | |
|--------|------------|------|------|------------|------|------|
| | MIN | NOM | MAX | MIN | NOM | MAX |
| A | 1.00 | 1.10 | 1.20 | .039 | .043 | .047 |
| A1 | 0.05 | 0.10 | 0.15 | .002 | .004 | .006 |
| A2 | 0.95 | 1.00 | 1.05 | .037 | .039 | .041 |
| D | 8.80 | 9.00 | 9.20 | .346 | .354 | .362 |
| D1 | 6.90 | 7.00 | 7.10 | .272 | .276 | .280 |
| E | 8.80 | 9.00 | 9.20 | .346 | .354 | .362 |
| E1 | 6.90 | 7.00 | 7.10 | .272 | .276 | .280 |
| L | 0.45 | 0.60 | 0.75 | .018 | .024 | .030 |
| e | 0.80 BSC. | | | .0315 BSC. | | |
| b | 0.30 | 0.37 | 0.45 | .012 | .015 | .018 |
| c | 0.13 | 0.16 | 0.20 | .005 | .006 | .008 |

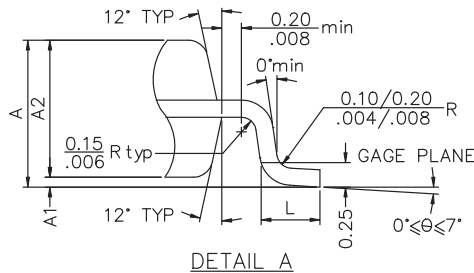

Packaging

32-pin plastic TQFP (suffix Q)

For exact mechanical package dimensions please see austriamicrosystems_{AG} packaging information.

Pin-out, Marking

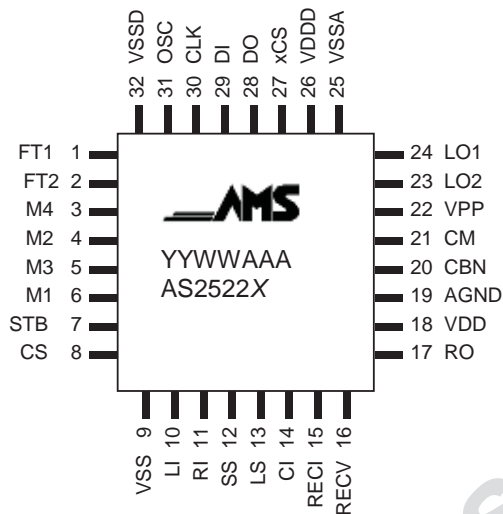

| | |
|-----|---|
| YY | year of production |
| WW | calendar week of production |
| AAA | austriamicrosystems _{AG} assembly ID |
| X | revision |

Ordering Information

| Number | Package | Description |
|-----------|---------|--|
| AS2522B Q | TQFP | plastic thin quad flat package – 32 leads (suffix T) |
| AS2522B F | DOF | Dice-on-Foil |

Devices sold by austriamicrosystems AG are covered by the warranty and patent identification provisions appearing in its Term of Sale. austriamicrosystems AG makes no warranty, express, statutory, implied, or by description regarding the information set forth herein or regarding the freedom of the described devices from patent infringement. austriamicrosystems AG reserves the right to change specifications and prices at any time and without notice. Therefore, prior to designing this product into a system, it is necessary to check with austriamicrosystems AG for current information. This product is intended for use in normal commercial applications. Applications requiring extended temperature range, unusual environmental requirements, or high reliability applications, such as military, medical life-support or life-sustaining equipment are specifically not recommended without additional processing by austriamicrosystems AG for each application.

Copyright

Copyright © 1997-2002, austriamicrosystems AG, Schloss Premstaetten, 8141 Unterpremstaetten, Austria-Europe. Trademarks Registered ®. All rights reserved. The material herein may not be reproduced, adapted, merged, translated, stored, or used without the prior written consent of the copyright owner.

The information furnished here by austriamicrosystems AG is believed to be correct and accurate. However, austriamicrosystems AG shall not be liable to recipient or any third party for any damages, including but not limited to personal injury, property damage, loss of profits, loss of use, interruption of business or indirect, special, incidental or consequential damages, of any kind, in connection with or arising out of the furnishing, performance or use of the technical data herein. No obligation or liability to recipient or any third party shall arise or flow out of austriamicrosystems AG rendering of technical or other services.

Contact

Headquarters

austriamicrosystems AG
Communications Business Unit
A 8141 Schloss Premstätten, Austria
T. +43 (0) 3136 500 0
F. +43 (0) 3136 525 01
www.austriamicrosystems.com

Sales Offices

Germany

austriamicrosystems Germany GmbH
Tegernseer Landstrasse 85
D-81539 München, Germany
Phone: +49/89/693643-0
Fax: +49/89/693643-66

France

austriamicrosystems France S.a.r.l.
124, Avenue de Paris
F-94300 Vincennes, France
Phone: +33/1/43 74 00 90
Fax: +33/1/43 74 20 98

Italy

austriamicrosystems Italy S.r.l.
Via Leone Tolstoi, 64
I-20146 Milano, Italy
Phone: +39/0242/36713
Fax: +39/0242/290889

Switzerland

austriamicrosystems Switzerland AG
Rietstrasse 4
CH-8640 Rapperswil, Switzerland
Phone: +41/55/220 9000
Fax: +41/55/220 9001

USA (west)

austriamicrosystems USA, Inc.
Suite 116, 4030 Moorpark Ave.,
San Jose, CA 95117, USA
Phone: +1/408/345 1790
Fax: +1/408/345 1795

USA (east)

austriamicrosystems USA, Inc.
Suite 400, 8601 Six Forks Road
Raleigh, NC 27615, USA
Phone: +1/919/676 5292
Fax: +1/919/676 5305

United Kingdom

austriamicrosystems UK, Ltd.
Coliseum Business Centre, Watchmoor Park
Camberley, Surrey, GU15 3YL, UK
Phone: +44/1276/23 3 99
Fax: +44/1276/29 3 53

Japan

austriamicrosystems AG
Shin Yokohama Daini, Center Bldg. 10F
3-19-5, Shin Yokohama
Kohoku-ku, Yokohama 222-0033, Japan
Phone: +81/45/474 0962
Fax: +81/45/472 9845

Distributors & Representatives

austriamicrosystems AG is represented by distributors in the following countries. Please contact your nearest regional sales office for the distributor address:

Spain, Israel, Korea, Hong-Kong, Taiwan, Malaysia, Singapore, India, Brazil

Application Support

Please contact your local sales office or your distributor.