

DESIGNED & DIMENSIONED
IN MILLIMETERS [INCHES]

DO NOT
SCALE FROM
THIS PRINT

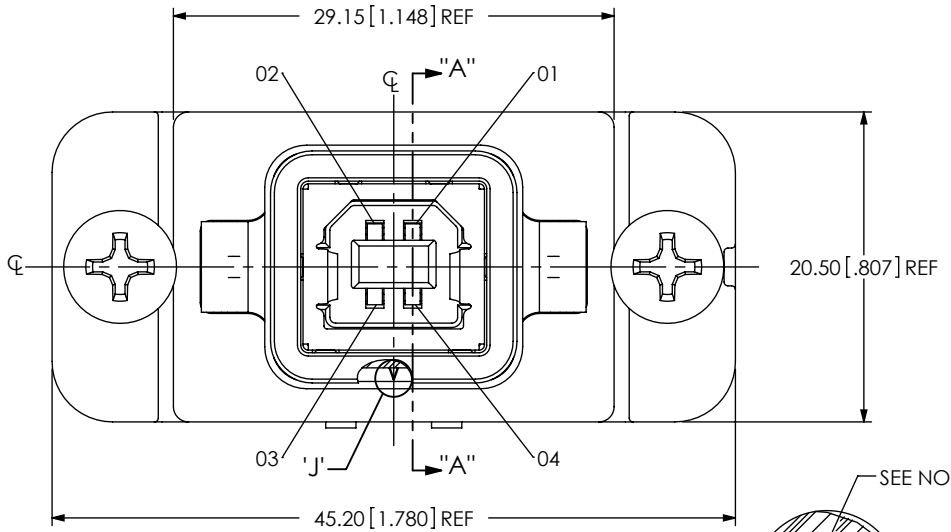

RPBU-XX-X-B-XX-XX

No Of POSITIONS
-01

PLATING SPECIFICATION
-S: SELECTIVE, .000030 GOLD ON POST, TIN ON TAIL

TYPE
-B

OPTION
-LC: LOCKING CLIP (AVAILABLE ON -VT ONLY)

TERMINATION
-RA: RIGHT ANGLE (SHEET 1, FIG 1)
-VT: VERTICAL THROUGH HOLE (SHEET 2, FIG 2)

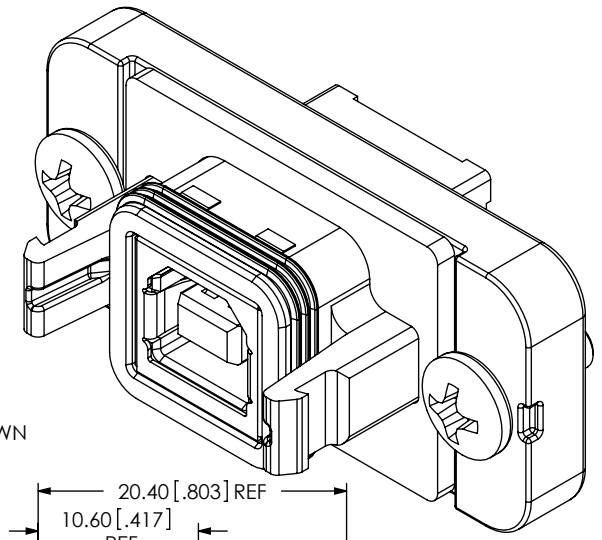
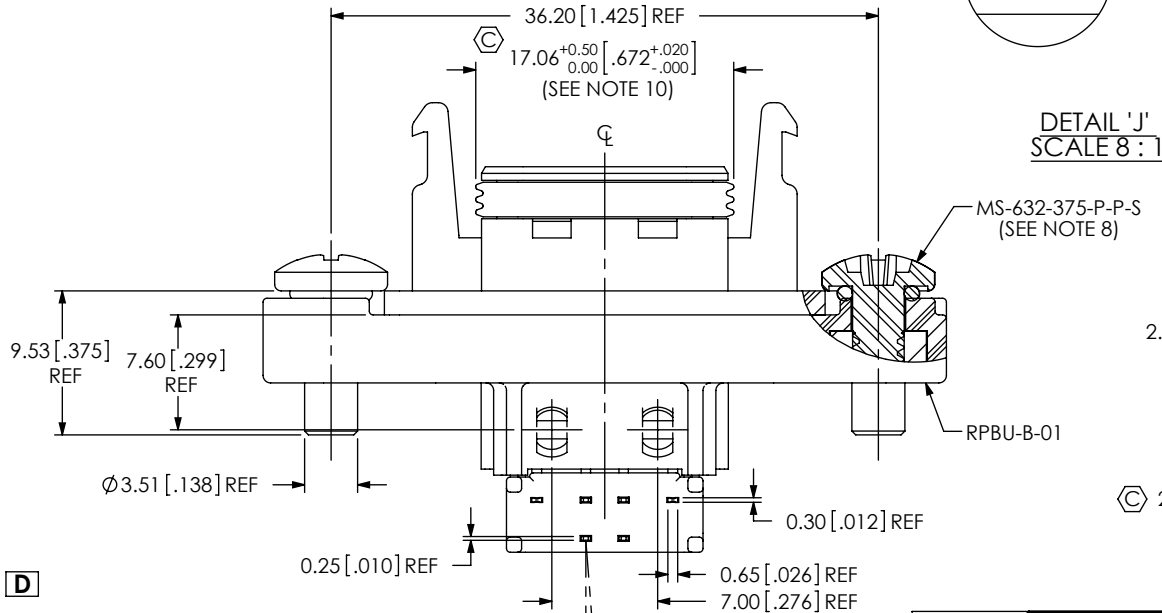
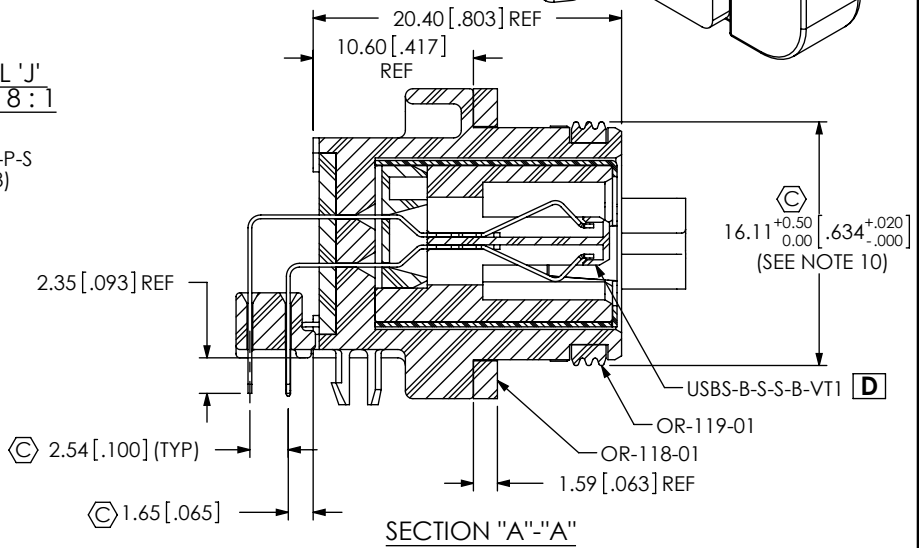

FIG 1
RPBU-01-X-B-RA SHOWN



DETAIL 'J'
SCALE 8:1



D

- NOTES:
- ⊙ REPRESENTS A CRITICAL DIMENSION.
 - BURR ALLOWANCE: 0.038[.0015] MAX.
 - MINIMUM PUSHOUT FORCE: 4.4N[1.00 LB].
 - MAXIMUM ALLOWABLE BOW: 0.05[.002] MM/MM AFTER ASSEMBLY.
 - PANEL THICKNESS: 0.76[.030] - 3.96[.156], RECOMMENDED PANEL CUT OUT ON SHEET 2.
 - REQUIRED TORQUE ON MS-632-375-P-P-S: .35±.07 Nm [50±10 IN-OZ].
 - ALL PARTS MUST BE PACKAGED IN TUBES.
 - SEAL O-RING IS INCLUDED IN THE MS-632-375-P-P-S.
 - EPOXY MUST BE FLUSH OR BELOW EDGE OF CAVITY. NO VOIDS IN EPOXY ALLOWED.
 - MEASURE O-RING IN THE CENTER OF THE PART.
 - PARTS TO BE OVEN CURED, AFTER THE EPOXY IS FILLED, AT 200°C FOR 10 MINUTES.
 - OR-119-XX POSITION INDICATOR.

CPC FREQUENCY THIS SHEET	UNLESS OTHERWISE SPECIFIED, DIMENSIONS ARE IN MILLIMETERS [INCHES]. TOLERANCES ARE:	PROPRIETARY NOTE
A	DECIMALS ANGLES X.X: ±0.3 [0.1] X.XX: ±0.13 [0.05] X.XXX: ±0.051 [0.020]	THIS DOCUMENT CONTAINS INFORMATION CONFIDENTIAL AND PROPRIETARY TO SAMTEC, INC. AND SHALL NOT BE REPRODUCED OR TRANSFERRED TO OTHER DOCUMENTS OR DISCLOSED TO OTHERS OR USED FOR ANY PURPOSE OTHER THAN THAT WHICH IT WAS OBTAINED WITHOUT THE EXPRESSED WRITTEN CONSENT OF SAMTEC, INC.
B	MATERIAL: DO NOT SCALE DRAWING	SHEET SCALE: 2:1
C	INSULATOR: LCP UL94V0, COLOR: BLACK CONTACT: PHOS BRONZE SHIELD: PHOS BRONZE SEAL: SILICON SCREW: STAINLESS STEEL NUT: STAINLESS STEEL	
D	F:\DWG\MISC\MKTG\RPBU-XX-X-B-XX-XX-MKT.SLDDRW	

samtec

520 PARK EAST BLVD, NEW ALBANY, IN 47150
PHONE: 812-944-6733 FAX: 812-948-5047
e-Mail: info@SAMTEC.COM code 53322

DESCRIPTION:
RECTANGULAR PANEL BOARD MOUNT USB-B

DWG. NO.
RPBU-XX-X-B-XX-XX

BY: VICKY Z 03/29/2010 SHEET 1 OF 6

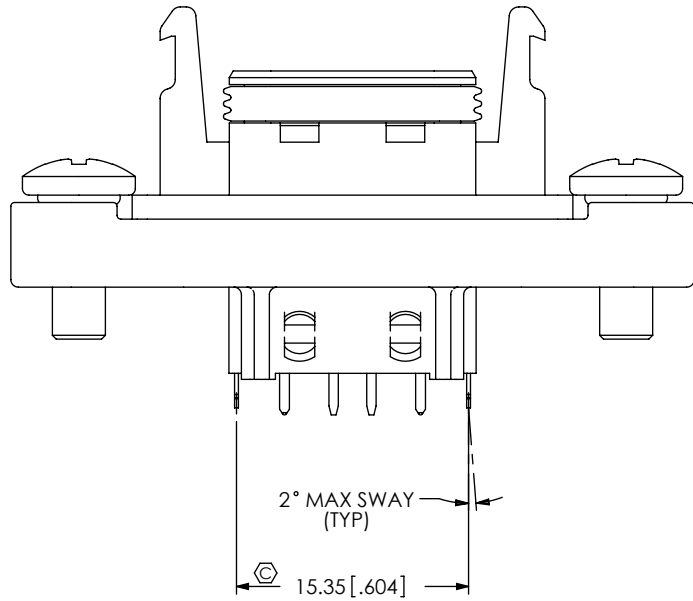
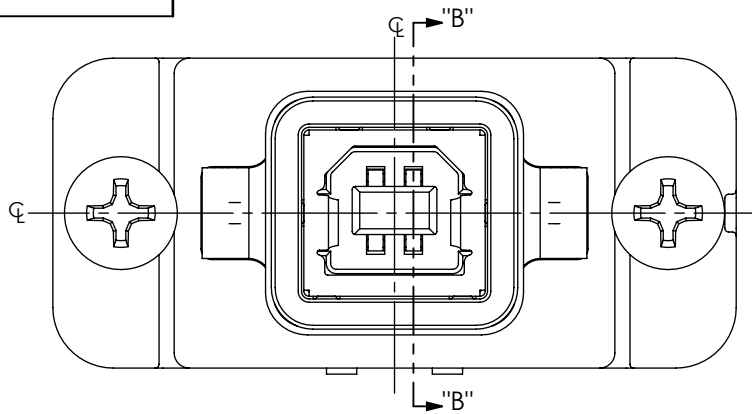
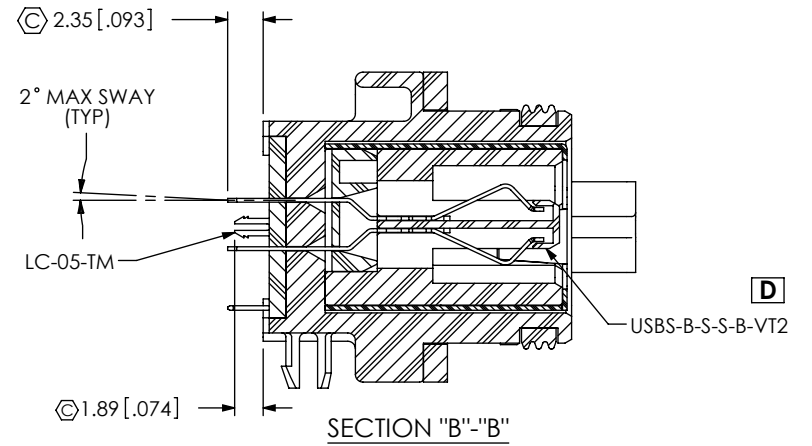
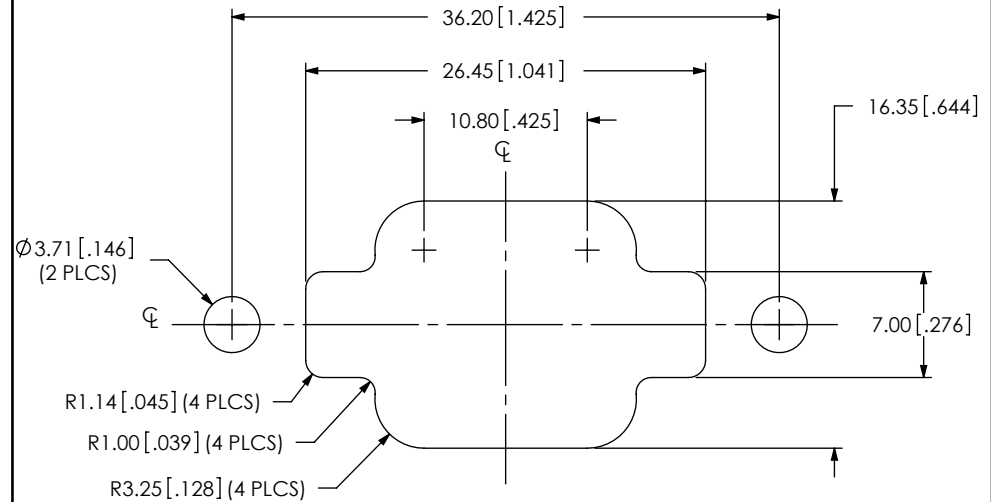

FIG 2
RPBU-01-X-B-VT-LC SHOWN
(SAME AS FIG 1, EXCEPT AS SHOWN)



RECOMMENDED PANEL CUT OUT
(SEE NOTE 5)



D

CPC FREQUENCY THIS SHEET	
A	
B	C5, C6, C7
C	
D	

PROPRIETARY NOTE
THIS DOCUMENT CONTAINS INFORMATION
CONFIDENTIAL AND PROPRIETARY TO
SAMTEC, INC. AND SHALL NOT BE REPRODUCED
OR TRANSFERRED TO OTHER DOCUMENTS OR
DISCLOSED TO OTHERS OR USED FOR ANY
PURPOSE OTHER THAN THAT WHICH IT WAS
OBTAINED WITHOUT THE EXPRESSED WRITTEN
CONSENT OF SAMTEC, INC.

DO NOT SCALE DRAWING
SHEET SCALE: 2:1



520 PARK EAST BLVD, NEW ALBANY, IN 47150
PHONE: 812-944-6733 FAX: 812-948-5047
e-Mail info@SAMTEC.com code 55322

DESCRIPTION:
RECTANGULAR PANEL BOARD MOUNT USB-B
DWG. NO. **RPBU-XX-X-B-XX-XX**
BY: VICKY Z 03/29/2010 SHEET 2 OF 6

REVISION D

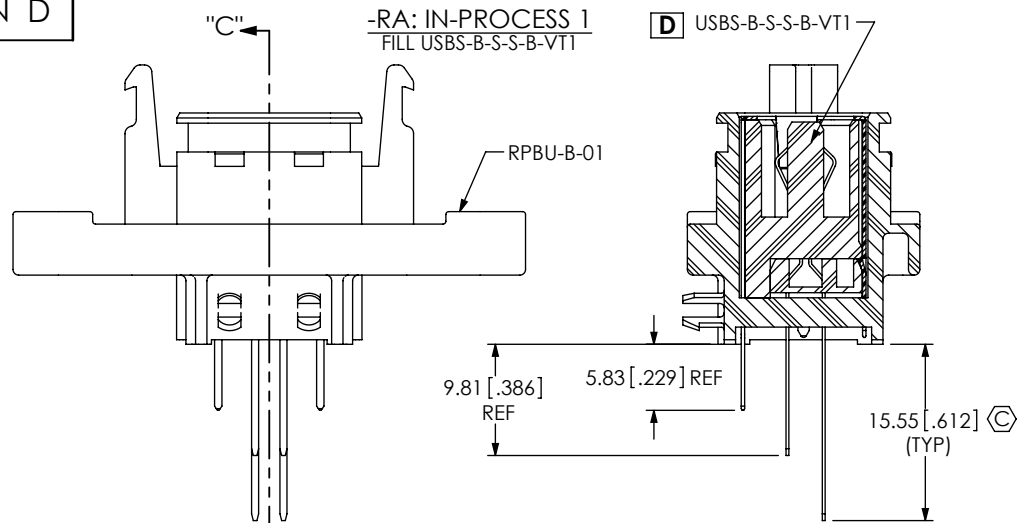

SECTION "C"- "C"

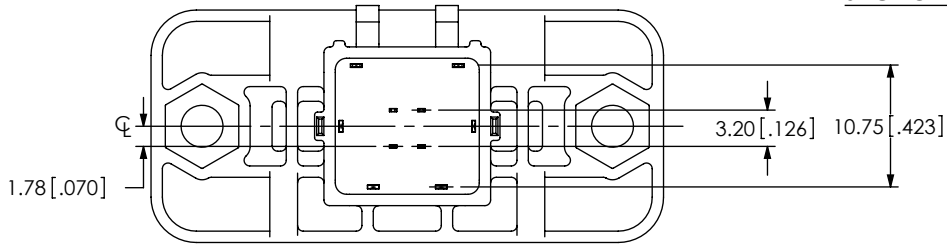

-RA: IN-PROCESS 2
FORM SHIELD TAILS ON USBS-B-S-S-B-VT1 **D**

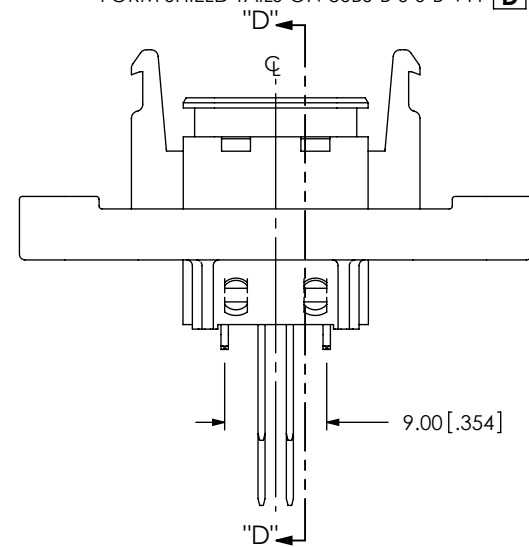

SECTION "D"- "D"

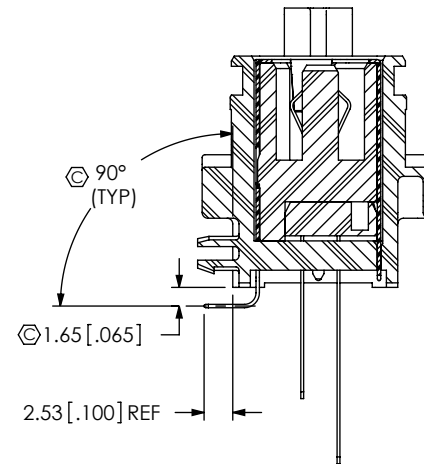

-RA: IN-PROCESS 3
FORM 1ST ROW CONTACTS

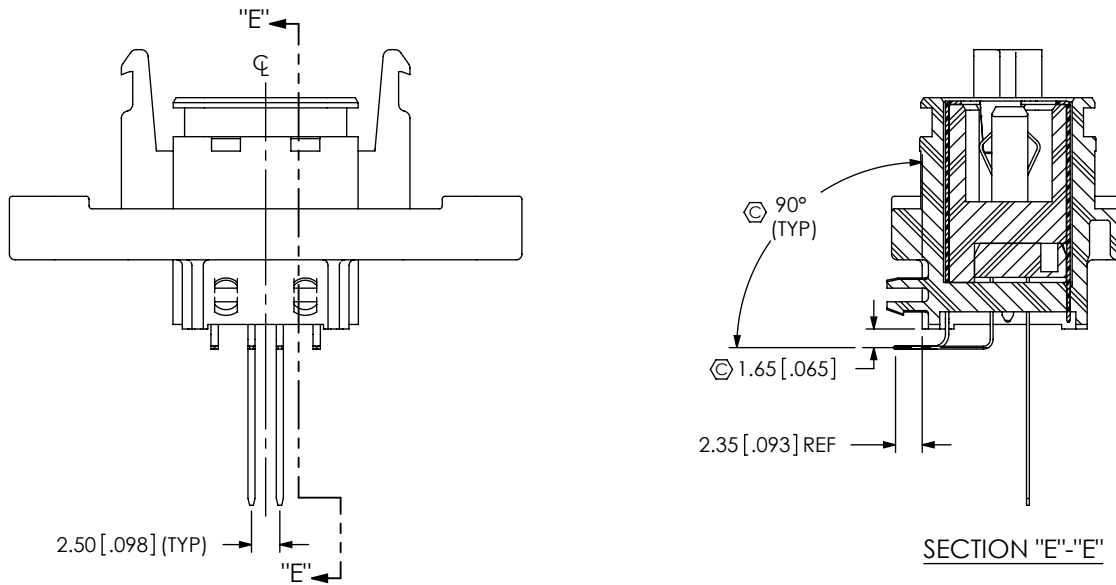

SECTION "E"- "E"

CPC FREQUENCY THIS SHEET	
A	
B	C3, C8, C10, C13
C	
D	

PROPRIETARY NOTE
THIS DOCUMENT CONTAINS INFORMATION CONFIDENTIAL AND PROPRIETARY TO SAMTEC, INC. AND SHALL NOT BE REPRODUCED OR TRANSFERRED TO OTHER DOCUMENTS OR DISCLOSED TO OTHERS OR USED FOR ANY PURPOSE OTHER THAN THAT WHICH IT WAS OBTAINED WITHOUT THE EXPRESSED WRITTEN CONSENT OF SAMTEC, INC.

DO NOT SCALE DRAWING

SHEET SCALE: 3:2

samtec

520 PARK EAST BLVD, NEW ALBANY, IN 47150
PHONE: 812-944-6733 FAX: 812-948-5047
e-Mail info@SAMTEC.com code 55322

DESCRIPTION:
RECTANGULAR PANEL BOARD MOUNT USB-B

DWG. NO. **RPBU-XX-X-B-XX-XX**

BY: VICKY Z 03/29/2010 SHEET 3 OF 6

-RA: IN-PROCESS 4
FORM 2ND ROW CONTACTS

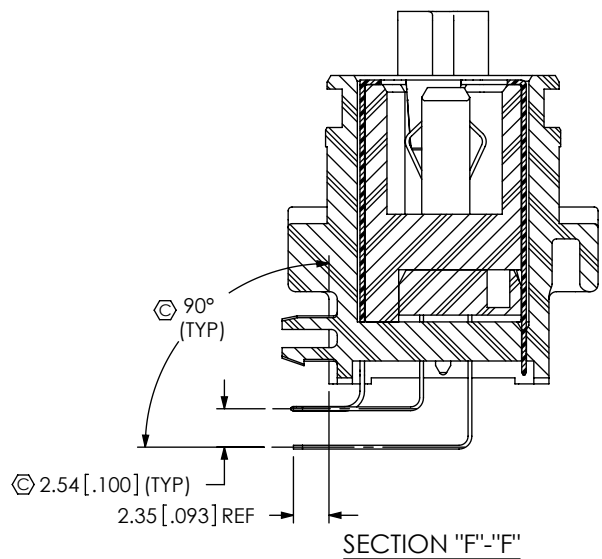
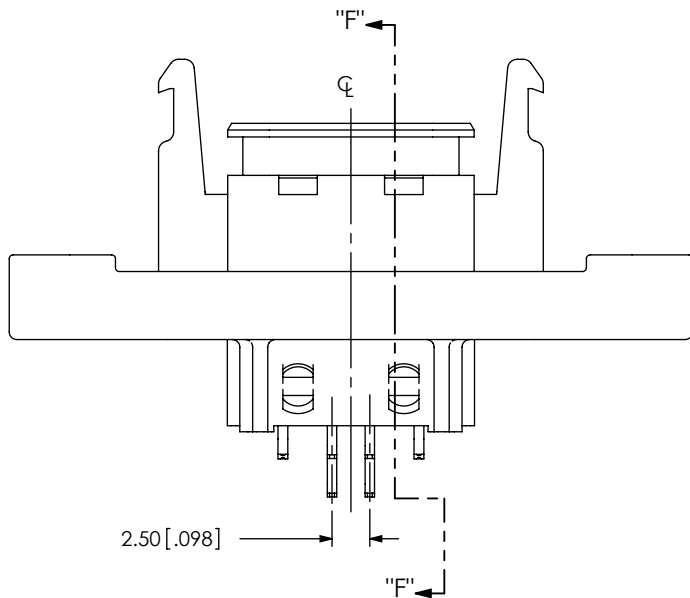

-RA: IN-PROCESS 5
FILL DCN-01-06-32 & HEAT STAKE

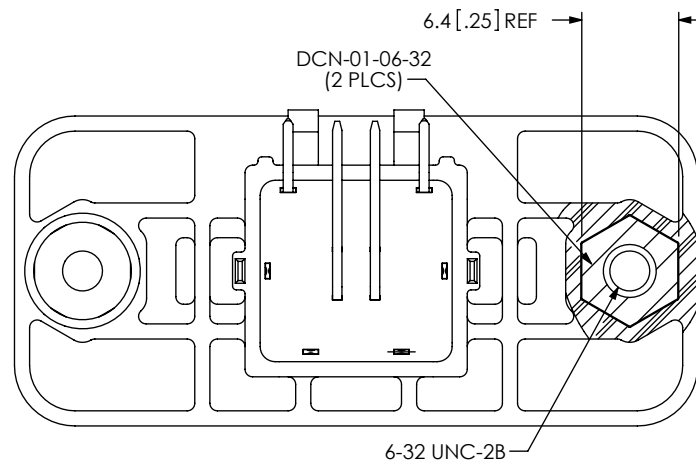
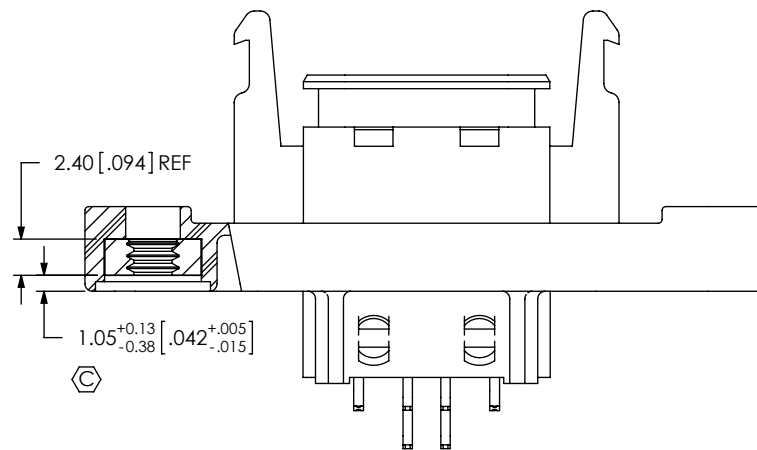

CPC
FREQUENCY
THIS SHEET

A	
B	C2, C15, C16
C	
D	

PROPRIETARY NOTE
THIS DOCUMENT CONTAINS INFORMATION
CONFIDENTIAL AND PROPRIETARY TO
SAMTEC, INC. AND SHALL NOT BE REPRODUCED
OR TRANSFERRED TO OTHER DOCUMENTS OR
DISCLOSED TO OTHERS OR USED FOR ANY
PURPOSE OTHER THAN THAT WHICH IT WAS
OBTAINED WITHOUT THE EXPRESSED WRITTEN
CONSENT OF SAMTEC, INC.

DO NOT SCALE DRAWING

SHEET SCALE: 2:1

samtec

520 PARK EAST BLVD, NEW ALBANY, IN 47150
PHONE: 812-944-6733 FAX: 812-948-5047
e-Mail: info@SAMTEC.com code 55322

DESCRIPTION:
RECTANGULAR PANEL BOARD MOUNT USB-B

DWG. NO.
RPBU-XX-X-B-XX-XX

BY: VICKY Z 03/29/2010 SHEET 4 OF 6

-RA: IN-PROCESS 6
FILL EPOXY-01

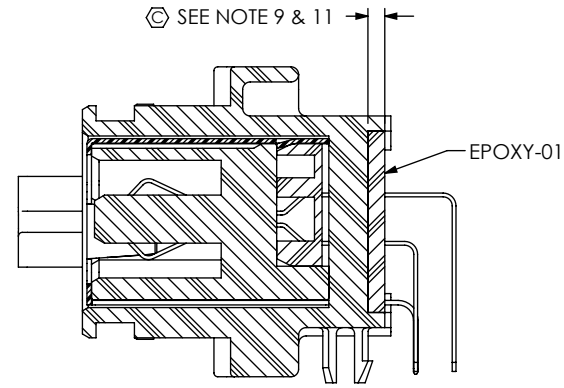
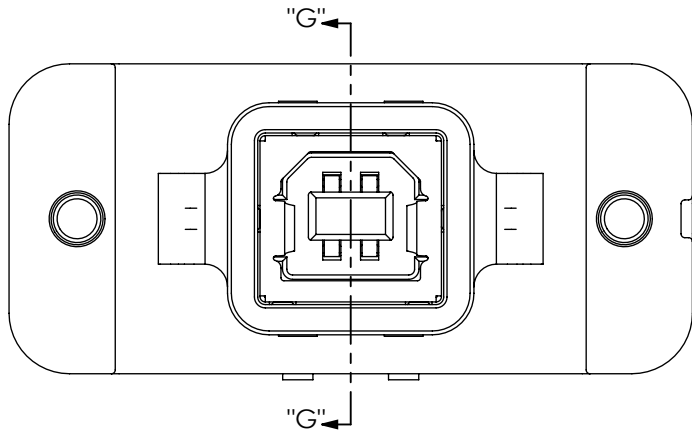

SECTION "G"- "G"

-RA: IN-PROCESS 7
ADD RPBU-B-XX-B

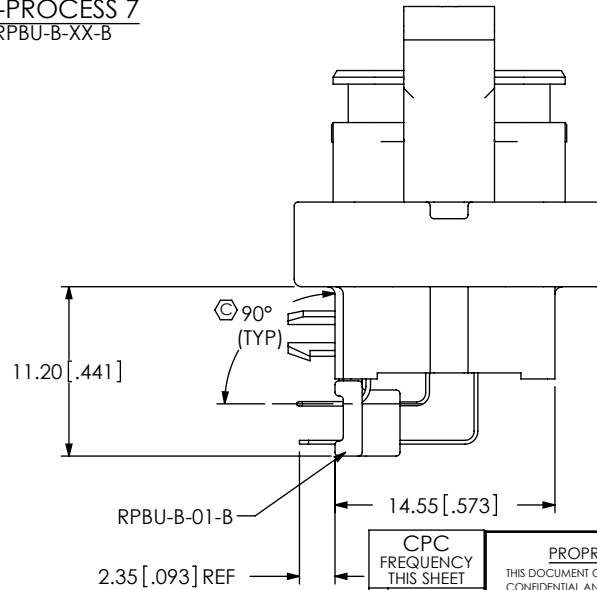
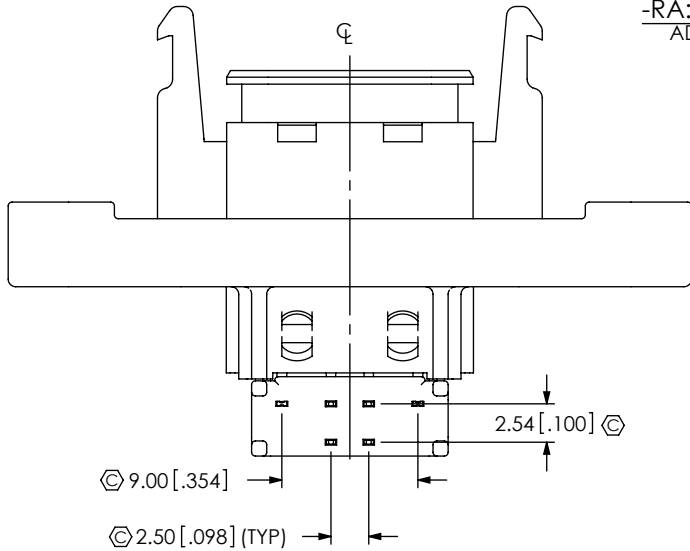

CPC FREQUENCY THIS SHEET	
A	
B	C2, C9, C12, C13
C	
D	C21

PROPRIETARY NOTE
THIS DOCUMENT CONTAINS INFORMATION CONFIDENTIAL AND PROPRIETARY TO SAMTEC, INC. AND SHALL NOT BE REPRODUCED OR TRANSFERRED TO OTHER DOCUMENTS OR DISCLOSED TO OTHERS OR USED FOR ANY PURPOSE OTHER THAN THAT WHICH IT WAS OBTAINED WITHOUT THE EXPRESSED WRITTEN CONSENT OF SAMTEC, INC.

DO NOT SCALE DRAWING

SHEET SCALE: 2:1

samtec

520 PARK EAST BLVD, NEW ALBANY, IN 47150
PHONE: 812-944-6733 FAX: 812-948-5047
e-Mail info@SAMTEC.com code 55322

DESCRIPTION:
RECTANGULAR PANEL BOARD MOUNT USB-B

DWG. NO. **RPBU-XX-X-B-XX-XX**

BY: VICKY Z 03/29/2010 SHEET 5 OF 6

REVISION D

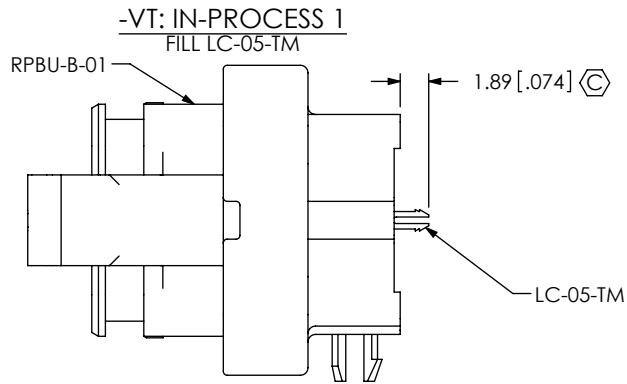

-VT: IN-PROCESS 3
FILL DCN-01-06-32 & HEAT STAKE
(SAME AS -RA: IN-PROCESS 5, EXCEPT AS SHOWN)

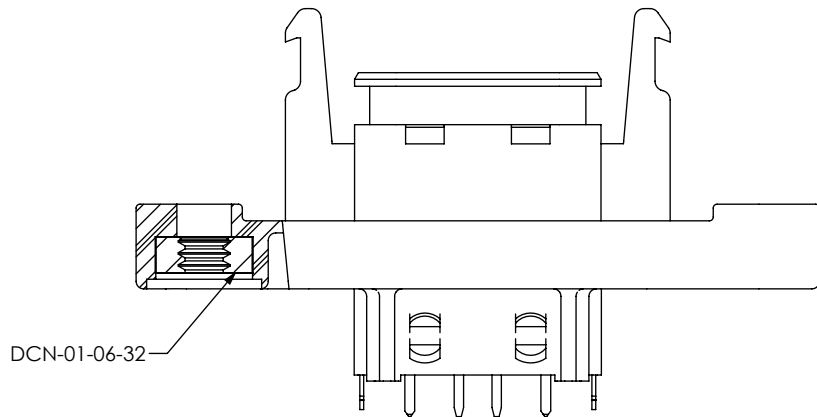

-VT: IN-PROCESS 4
FILL EPOXY-01
(SAME AS -RA: IN-PROCESS 6, EXCEPT AS SHOWN)

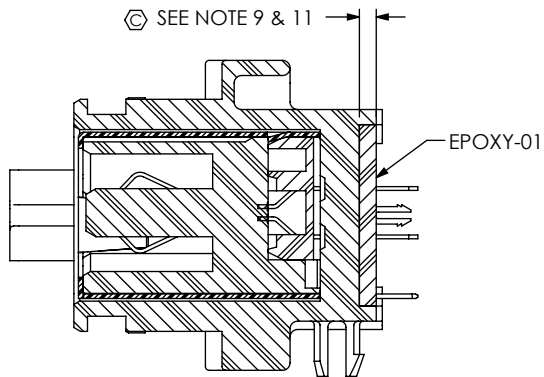

PACKAGING VIEW
(SEE NOTE 7)

TUBE: PT-RPBU002
PLUG: TP-50

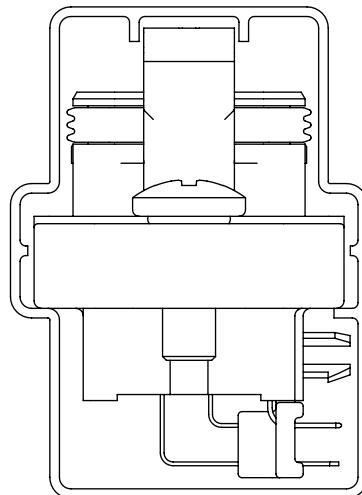

F:\DWG\MISC\MKTG\RPBU-XX-X-B-XX-XX-MKT.SLDDRW

-VT: IN-PROCESS 2 D
FILL USBS-B-S-S-B-VT2
(SAME AS -RA: IN-PROCESS 1, EXCEPT AS SHOWN)

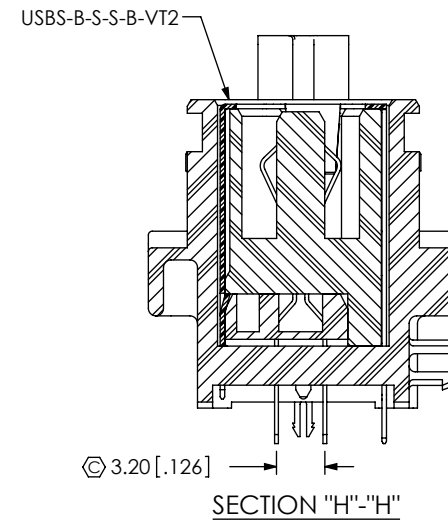
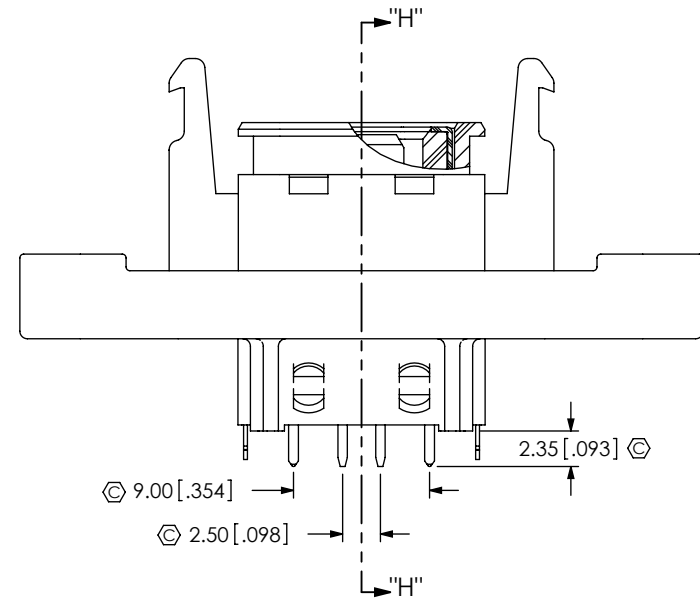

CPC
FREQUENCY
THIS SHEET

A	
B	C5, C6, C17, C18, C19
C	
D	C21

PROPRIETARY NOTE
THIS DOCUMENT CONTAINS INFORMATION
CONFIDENTIAL AND PROPRIETARY TO
SAMTEC, INC. AND SHALL NOT BE REPRODUCED
OR TRANSFERRED TO OTHER DOCUMENTS OR
DISCLOSED TO OTHERS OR USED FOR ANY
PURPOSE OTHER THAN THAT WHICH IT WAS
OBTAINED WITHOUT THE EXPRESSED WRITTEN
CONSENT OF SAMTEC, INC.

DO NOT SCALE DRAWING

SHEET SCALE: 2:1

samtec

520 PARK EAST BLVD, NEW ALBANY, IN 47150
PHONE: 812-944-6733 FAX: 812-948-5047
e-Mail: info@SAMTEC.com code 55322

DESCRIPTION:
RECTANGULAR PANEL BOARD MOUNT USB-B

DWG. NO.
RPBU-XX-X-B-XX-XX

BY: VICKY Z 03/29/2010 SHEET 6 OF 6