

MAX22190 Evaluation System

Evaluates: MAX22190

General Description

The MAX22190 evaluation system (EV system) provides the hardware and software necessary to evaluate the MAX22190 Octal Industrial Digital Input device with Diagnostic features. The MAX22190 EV kit has Pmod™ compatible connector for SPI communication. The EV system includes the USB2PMB2# adapter board that receives commands from a PC through the USB port to create an SPI interface for communication between the software and the MAX22190 on the EV kit.

The EV system includes a graphical user interface (GUI) that provides communication between the target device and the PC. The MAX22190 EV kit has two MAX22190 devices (U1 and U2) that can operate in multiple modes, as shown in [Figure 1](#):

- 1) Single-Channel Mode: The USB2PMB2# adapter connects to either U1 or U2 on the EV kit, depending on which channel is preferred, and selected using the on-board jumpers.
- 2) Independent Slave Mode: The USB2PMB2# adapter uses two chip-select signals ($\overline{CS1}$ and $\overline{CS2}$) to control each chip through a single connector/GUI interface.
- 3) Daisy-Chain Mode: The USB2PMB2# adapter connects to both U1 and U2 through the MAX14483 Digital Isolator, and SDO from U1 connects to SDI of U2. Both U1 and U2 are controlled from a single SPI interface.

EV System Contents

- MAX22190EVKIT#, including the MAX22190ATJ+
- USB2PMB2# Adapter Board
- Micro-USB Cable

Windows and Windows XP are registered trademarks and registered service marks of Microsoft Corporation.

Pmod is a trademark of Digilent, Inc

Features

- Easy Evaluation of the MAX22190
- EV Kit Logic Side is USB-Powered
- Configured for IEC 61131-2 Type 1, 3 and Type 2
- Independent Slave or Daisy-Chainable SPI Interface
- Galvanic Isolation using MAX14483 and MAX12931
- Robust Design $\pm 2\text{kV}$ Surge Tolerant Line-to-Line
- Windows® 10, Windows 8.1, Windows 7, and Windows XP® Compatible Software
- Fully Assembled and Tested
- Proven PCB Layout
- RoHS Compliant

[Ordering Information](#) appears at end of data sheet.

MAX22190 EV Kit

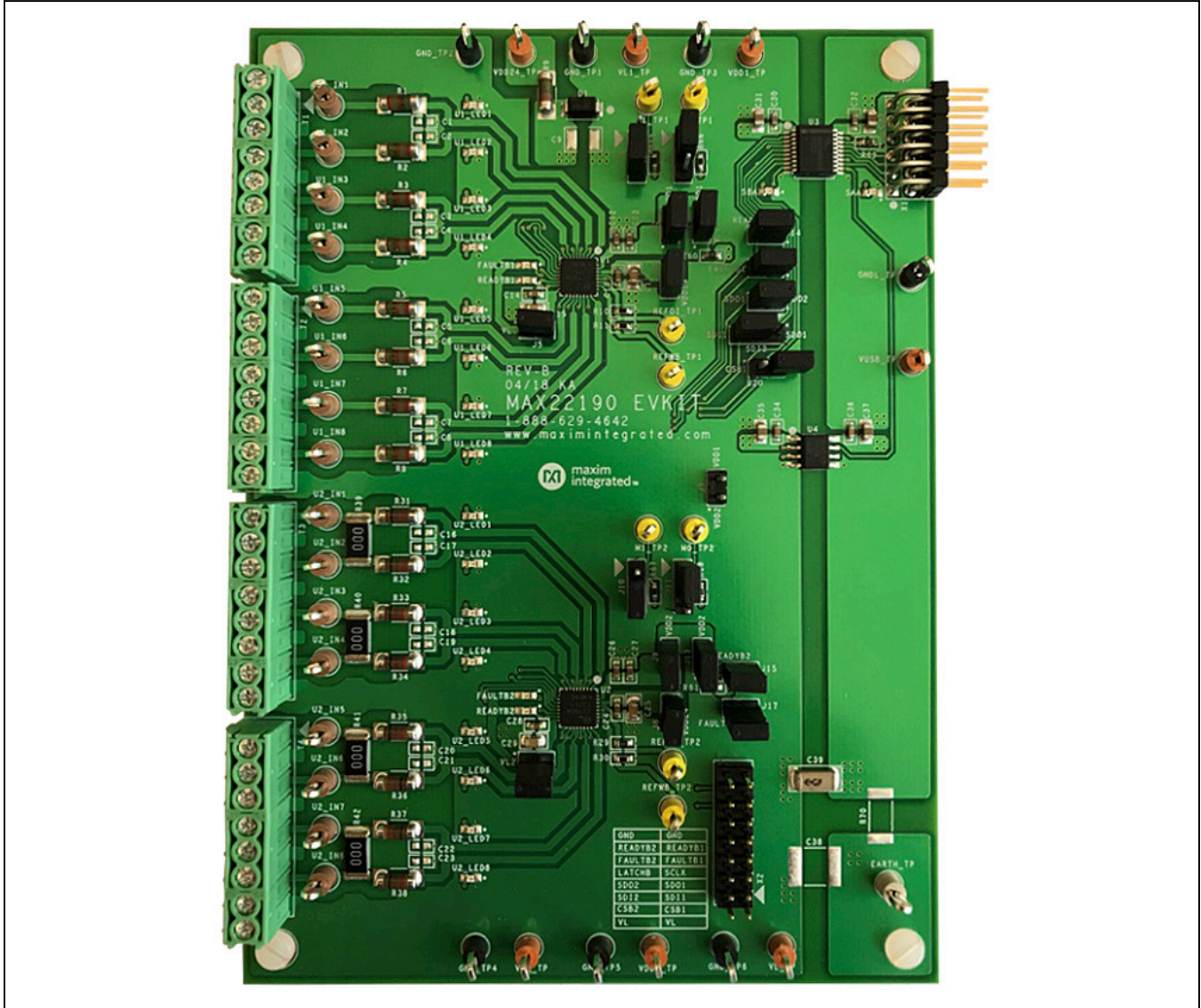

USB2PMB2 Adapter Board

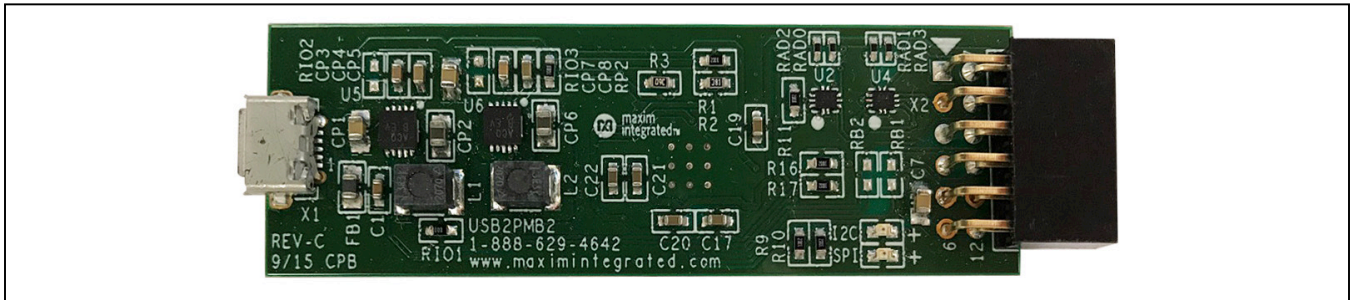

MAX22190 EV System

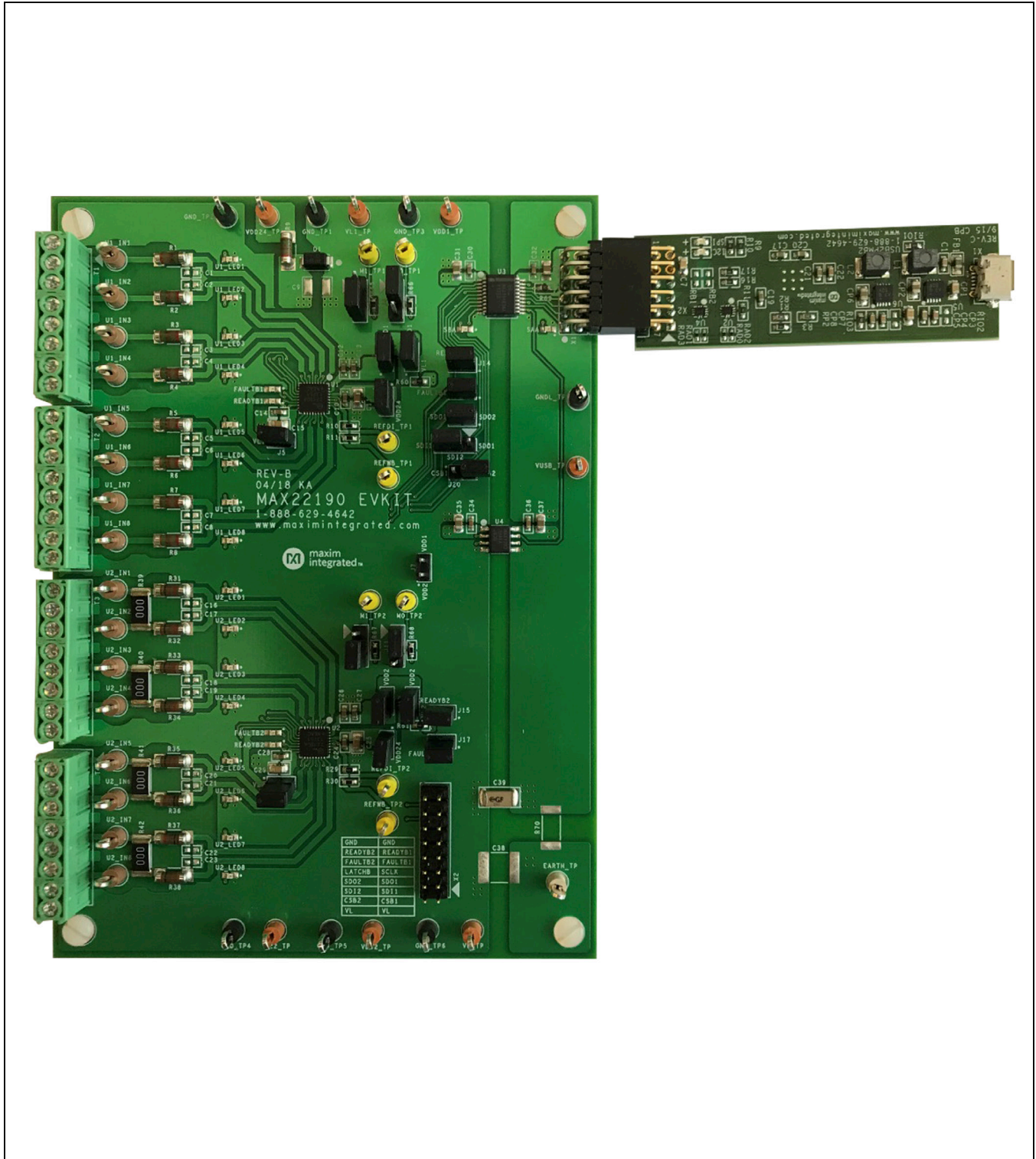

System Block Diagram

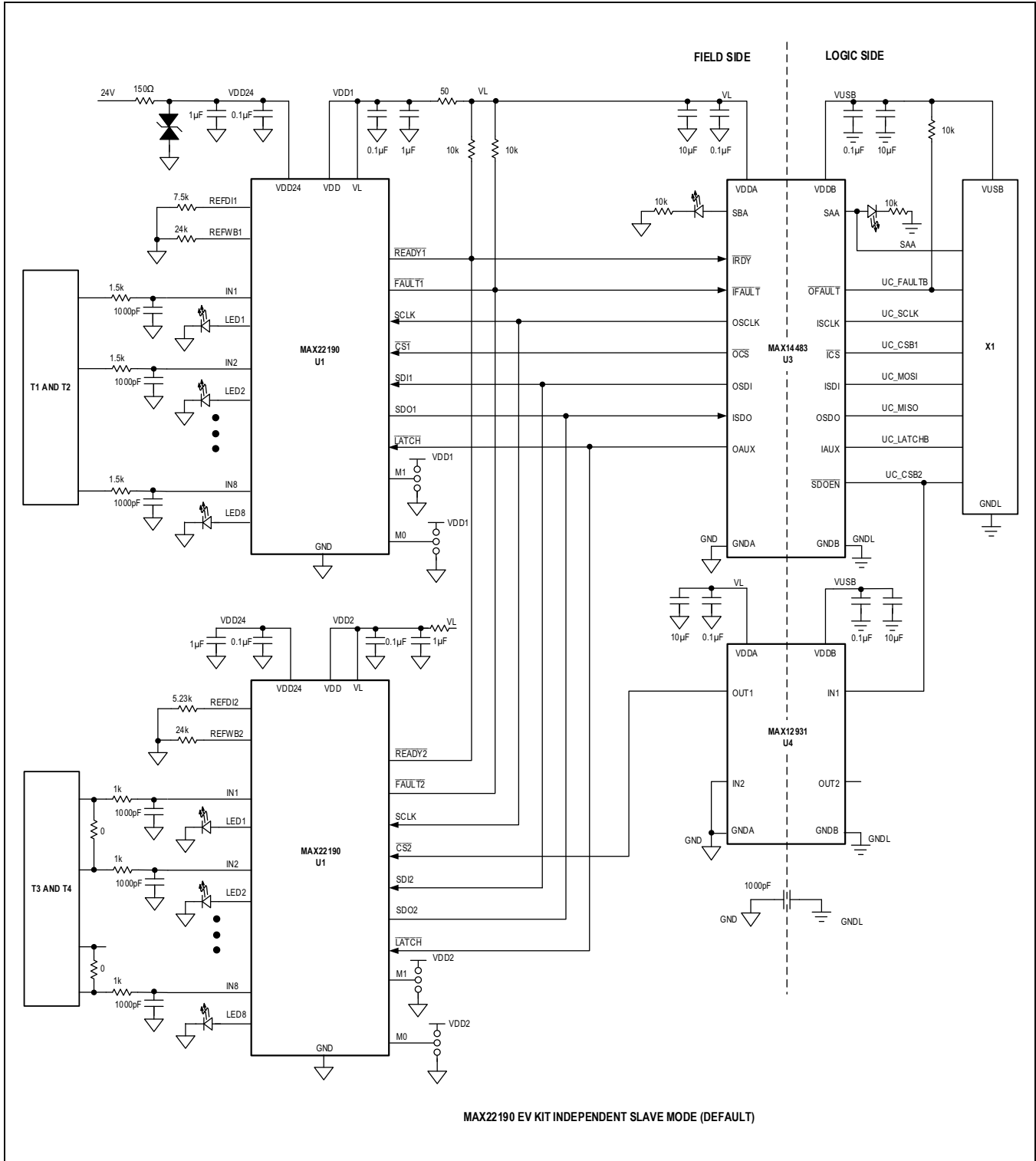

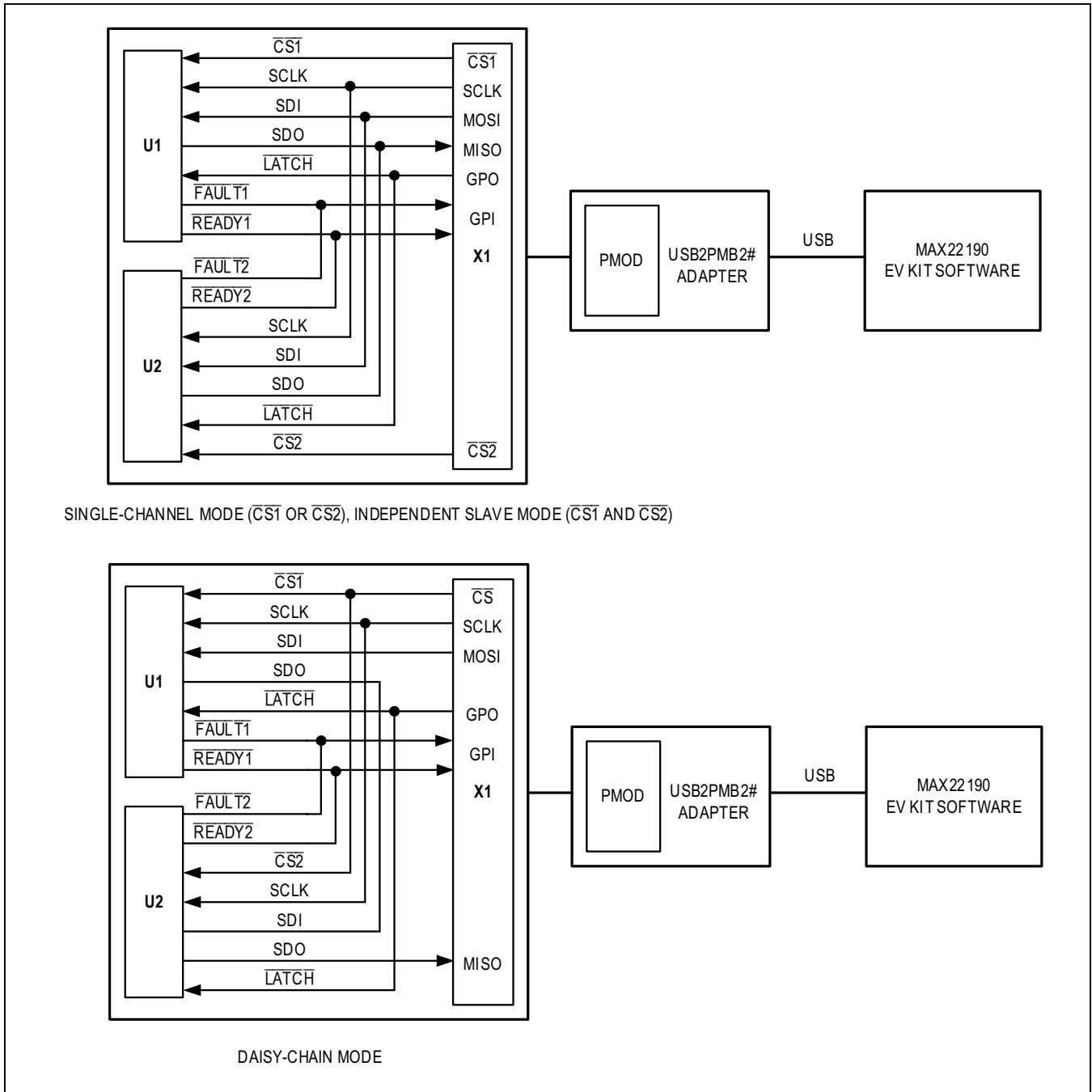

Figure 1: MAX22190 EV Kit Operation Modes

MAX22190 EV Kit Files

FILE	DESCRIPTION
MAX22190EVMSetupV1.00.ZIP	Application Program

Quick Start

Required Equipment

- MAX22190 EV kit
- USB2PMB2# adapter board
- Micro-USB cable
- 24V DC voltage supply
- Windows 10, Windows 8.1, Windows 7, Window XP PC with a spare USB port

Note: In the following sections, software-related items are identified by bolding. Text in **bold** refers to items directly from the EV kit software. Text in **bold and underline** refers to items from the Windows operating system.

Procedure

The EV kit is fully assembled and tested. The default jumper settings configure the EV kit to operate in the Independent Slave mode using both U1 and U2. In this configuration, the EV kit's "logic side" is powered by +3.3V from USB2PMB2# adapter connected to X1 Pmod connector, and the "field side" is powered by the external DC supply connected to VDD24 and GND. U1 is configured for eight Type 1 or Type 3 inputs (Terminal Blocks T1 and T2) and U2 is configured for four Type 2 inputs (Terminal Blocks T3 and T4). Follow the steps below to verify the MAX22190 operation:

- 1) Verify all jumper settings are in default position from [Table 1](#).
- 2) For initial testing, MAX22190 EV kit is powered from USB2PMB2# (+3.3V) from the Pmod connector and 24V at VDD24 and GND.
- 3) Visit www.maximintegrated.com to download the latest version of the EV kit software, MAX22190EVKit-SetupV1.00.ZIP.
- 4) Save the EV kit software to a temporary folder and uncompress the ZIP file.
- 5) Install the EV kit software and USB driver on your computer by running the MAX22190EVKitSetupV1.00.exe program inside the temporary folder. A message box asking **Do you want to allow the following program to make changes to this computer?** may appear. If so, click **Yes**.
- 6) The program files are copied to your PC and icons are created in the Windows **Start | Programs** menu. At the end of the installation process, the installer will launch the installation for the FTDI Chip CDM drivers.
- 7) The installer includes the drivers for the hardware and software. Follow the instructions on the installer and once complete, click **Finish**. The default location of the software is in the program files directory.
- 8) Connect the MAX22190 EV kit Pmod connector X1 to the connector on the USB2PMB2# adapter.
- 9) Connect the USB2PMB2# to the PC with the micro-USB cable. Windows should automatically recognize the device and display a message near the **System Icon** menu indicating that the hardware is ready to use.
- 10) Connect the DC power supply between the EV kit's VDD24_TP and GND_TP1 test points. Set the DC power supply output to 24V, and then enable the output. Observe that, on the EV kit, the FAULTB1, READYB1, FAULTB2, READYB2, SBA, and SAA LEDs are on, indicating the EV kit is powered up.
- 11) Once the hardware is ready to use, launch the EV kit software by opening its icon in the **Start | Programs** menu. During the EV kit software launch, two message boxes are shown to indicate the default operation mode (Independent Slave mode), and U1 and U2 SPI mode (Mode 0). Click **OK** to close the message boxes. The EV kit software appears as shown in [Figure 2](#).
- 12) Verify that the lower-right status bar indicates the EV kit hardware is **Connected**. If the status bar indicates **Disconnected**, from the **Device** menu, click **Connect to Hardware**. Then select a device in the list or use the default device already selected.
- 13) Click **Clear POR** button. Observe that **POR** status lights for U1 and U2 are changed to green, and **FAULT Signal** status light is also changed to green in the **Configuration** tab as shown in [Figure 3](#).
- 14) Observe that FAULTB1 and FAULTB2 LEDs on the EV kit are turned off.
- 15) Click **Read DI Continuously** button. The EV kit software reads the U1 and U2 DI registers continuously. Connect the 24V DC voltage to one of the input test points, for example, test point U1_IN5. The corresponding **Digital Inputs** status light **IN5** is changed to green from yellow to indicate U1 channel IN5 is high as shown in [Figure 4](#).

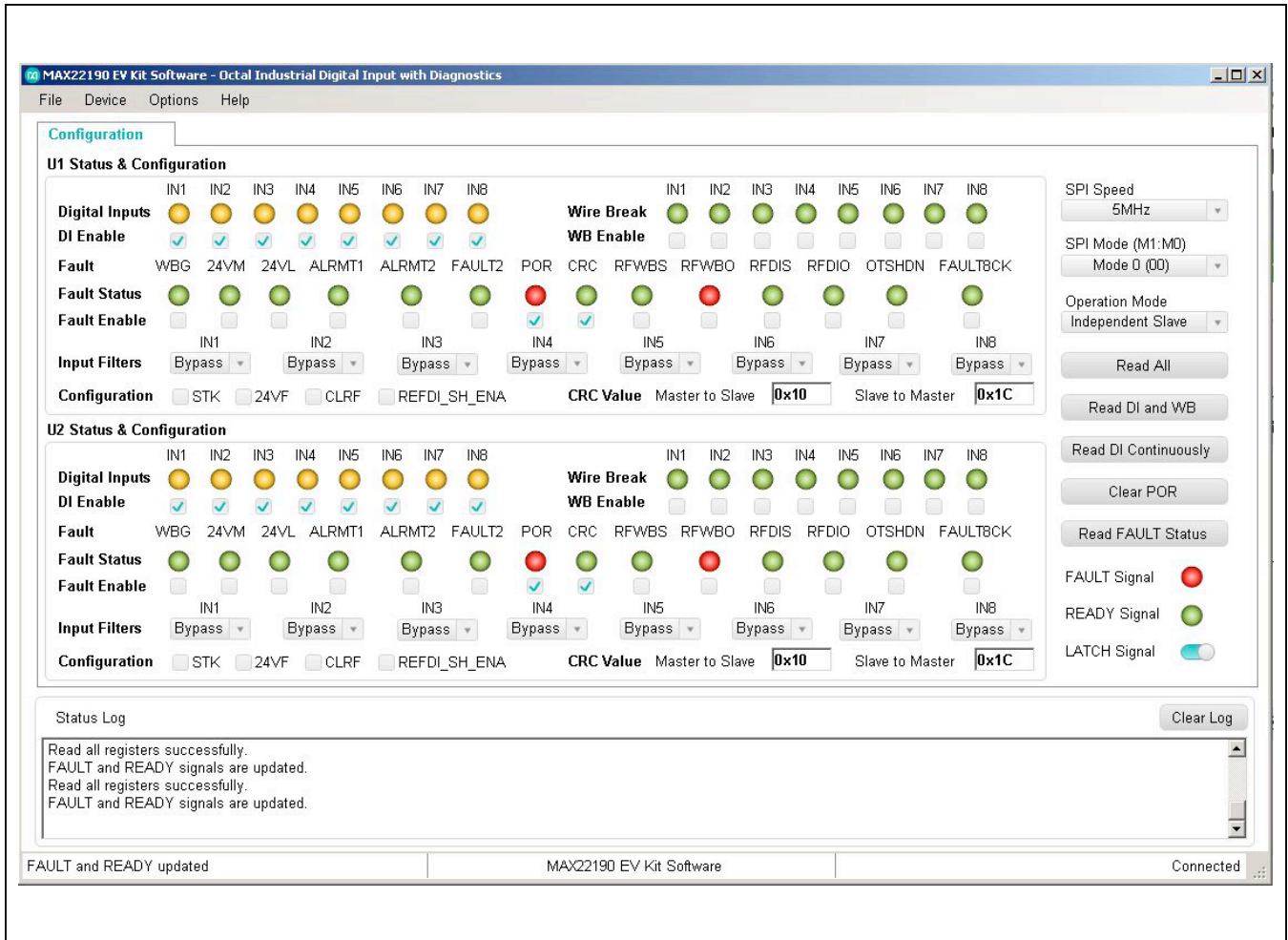

Figure 2. MAX22190 EV Kit Software Startup Window

Table 1. MAX22190 EV Kit Jumper Settings

JUMPER	SHUNT POSITION	DEVICE	DESCRIPTION
POWER			
J1	1 - 2*	U1	Connect external power supply to U1 VDD24
	Open		Use current meter to measure U1 VDD24 supply current
J2	1 - 2*	U1	Connect external power supply to U1 VDD or connect U1 VDD output to the EV kit
	Open		Use current meter to measure U1 VDD supply current
J5	1 - 2*	U1	Connect power supply to U1 VL
	Open		Use current meter to measure U1 VL supply current
J6	1 - 2*	U1	Connect U1 VDD supply to U1 VL supply
	Open		Connect external power supply from VL1_TP test point to U1 VL
J7	1 - 2	U1 and U2	Power both U1 and U2 by VDD with same external power supply
	Open*		Power U1 and U2 separately by VDD, or together by VDD24
J8	1 - 2*	U2	Connect external power supply to U2 VDD24
	Open		Use current meter to measure U2 VDD24 supply current
J9	1 - 2*	U2	Connect external power supply to U2 VDD or connect U2 VDD output to the EV kit
	Open		Use current meter to measure U2 VDD supply current
J12	1 - 2*	U2	Connect power supply to U2 VL
	Open		Use current meter to measure U2 VL supply current
J13	1 - 2*	U2	Connect U2 VDD supply to U2 VL supply
	Open		Connect external power supply from VL2_TP test point to U2 VL
SPI			
J3	1 - 2	U1	U1 SPI Mode M1 = 1
	2 - 3*		U1 SPI Mode M1 = 0
J4	1 - 2	U1	U1 SPI Mode M0 = 1
	2 - 3*		U1 SPI Mode M0 = 0
J10	1 - 2	U2	U2 SPI Mode M1 = 1
	2 - 3*		U2 SPI Mode M1 = 0
J11	1 - 2	U2	U2 SPI Mode M0 = 1
	2 - 3*		U2 SPI Mode M0 = 0
J14	1 - 2*	U1	Connect U1 $\overline{\text{READY}}$ to U3 MAX14483 $\overline{\text{IRDY}}$ channel
	Open		Disconnect U1 $\overline{\text{READY}}$ from U3 MAX14483 $\overline{\text{IRDY}}$ channel
J15	1 - 2*	U2	Connect U2 $\overline{\text{READY}}$ to U3 MAX14483 $\overline{\text{IRDY}}$ channel
	Open		Disconnect U2 $\overline{\text{READY}}$ from U3 MAX14483 $\overline{\text{IRDY}}$ channel
J16	1 - 2*	U1	Connect U1 $\overline{\text{FAULT}}$ to U3 MAX14483 $\overline{\text{IFAUULT}}$ channel
	Open		Disconnect U1 $\overline{\text{FAULT}}$ from U3 MAX14483 $\overline{\text{IFAUULT}}$ channel
J17	1 - 2*	U2	Connect U2 $\overline{\text{FAULT}}$ to U3 MAX14483 $\overline{\text{IFAUULT}}$ channel
	Open		Disconnect U2 $\overline{\text{FAULT}}$ from U3 MAX14483 $\overline{\text{IFAUULT}}$ channel
J18	1 - 2*	U1 and U2	Connect both U1 SDO and U2 SDO to U3 MAX14483 ISDO channel, used in Single Channel mode or Independent Slave mode
	Open		Disconnect U1 SDO and U2 SDO, used in Daisy-Chain mode

Table 1. MAX22190 EV Kit Jumper Settings (continued)

JUMPER	SHUNT POSITION	DEVICE	DESCRIPTION
J19	1 - 2	U1 and U2	Connect U2 SDI to U1 SDO, used in Daisy-Chain mode
	2 - 3*		Connect both U1 SDI and U2 SDI to U3 MAX14483 OSDI channel, used in Single Channel mode or Independent Slave mode
J20	1 - 2	U1 and U2	Connect both U1 \overline{CS} and U2 \overline{CS} to U3 MAX14483 \overline{OCS} channel, used in Daisy-Chain mode
	Open*		Disconnect U1 \overline{CS} and U2 \overline{CS} , used in Single Channel mode or Independent Slave mode
TEST or PROBE POINTS (NEVER INSTALL JUMPERS)			
X2	1, 2	VL, field-side logic supply	
	3	CSB1, U1 chip-select \overline{CS}	
	4	CSB2, U2 chip-select \overline{CS}	
	5	SDI1, U1 MOSI	
	6	SDI2, U2 MOSI	
	7	SDO1, U1 MISO	
	8	SDO2, U2 MISO	
	9	SCLK, U1 and U2 serial clock	
	10	LATCHB, U1 and U2 \overline{LATCH} signal	
	11	FAULTB1, U1 \overline{FAULT} signal	
	12	FAULTB2, U2 \overline{FAULT} signal	
	13	READYB1, U1 \overline{READY} signal	
	14	READYB2, U2 \overline{READY} signal	
	15, 16	GND, field-side ground	

*Default position.

Table 2. MAX22190 EV Kit Jumper Settings for Different Operation Modes

JUMPER	SINGLE CHANNEL U1	SINGLE CHANNEL U2	INDEPENDENT SLAVE MODE*	DAISY CHAIN MODE
J3	1 - 2	1 - 2	1 - 2*	2 - 3
J4	Don't Care	Don't Care	Don't Care*	Don't Care
J10	1 - 2	1 - 2	1 - 2*	2 - 3
J11	Don't Care	Don't Care	Don't Care*	Don't Care
J14	1 - 2	Open	1 - 2*	1 - 2
J15	Open	1 - 2	1 - 2*	1 - 2
J16	1 - 2	Open	1 - 2*	1 - 2
J17	Open	1 - 2	1 - 2*	1 - 2
J18	1 - 2	Don't Care	1 - 2*	Open
J19	2 - 3	2 - 3	2 - 3*	1 - 2
J20	Open	Open	Open*	1 - 2

*Default position.

Detailed Description of Software

When the MAX22190 EV kit software starts, it automatically detects if the EV kit is connected to a PC and indicates it in the status bar at the bottom edge of the GUI. If the software does not recognize the USB2PMB2# adapter board, make sure that the software and all drivers are properly installed, check the USB connection, and go to the **Device** menu and select **Search for Hardware** option. When the EV kit is properly connected, the MAX22190 devices (U1 and U2) are read and all controls are updated (see [Figure 2](#)).

The main window of the EV kit software contains three groups of controls: **U1 Status & Configuration**, **U2 Status & Configuration**, and general controls for the EV kit. The U1 or U2 Status and Configuration box provides the controls to directly configure MAX22190 features such as reading Digital Inputs, Wire-Break configuration, Input Filter configuration, fault status reporting, etc. The general controls for the EV kit allow the user to select the SCLK speed, EV kit operation mode, U1 and U2 SPI modes, LATCH signal level, etc. Next to the **Configuration** tab, the **Register Map** tab lists all registers in the MAX22190 and provides direct read and write access to all the control bits (not implemented until software rev. 2.0).

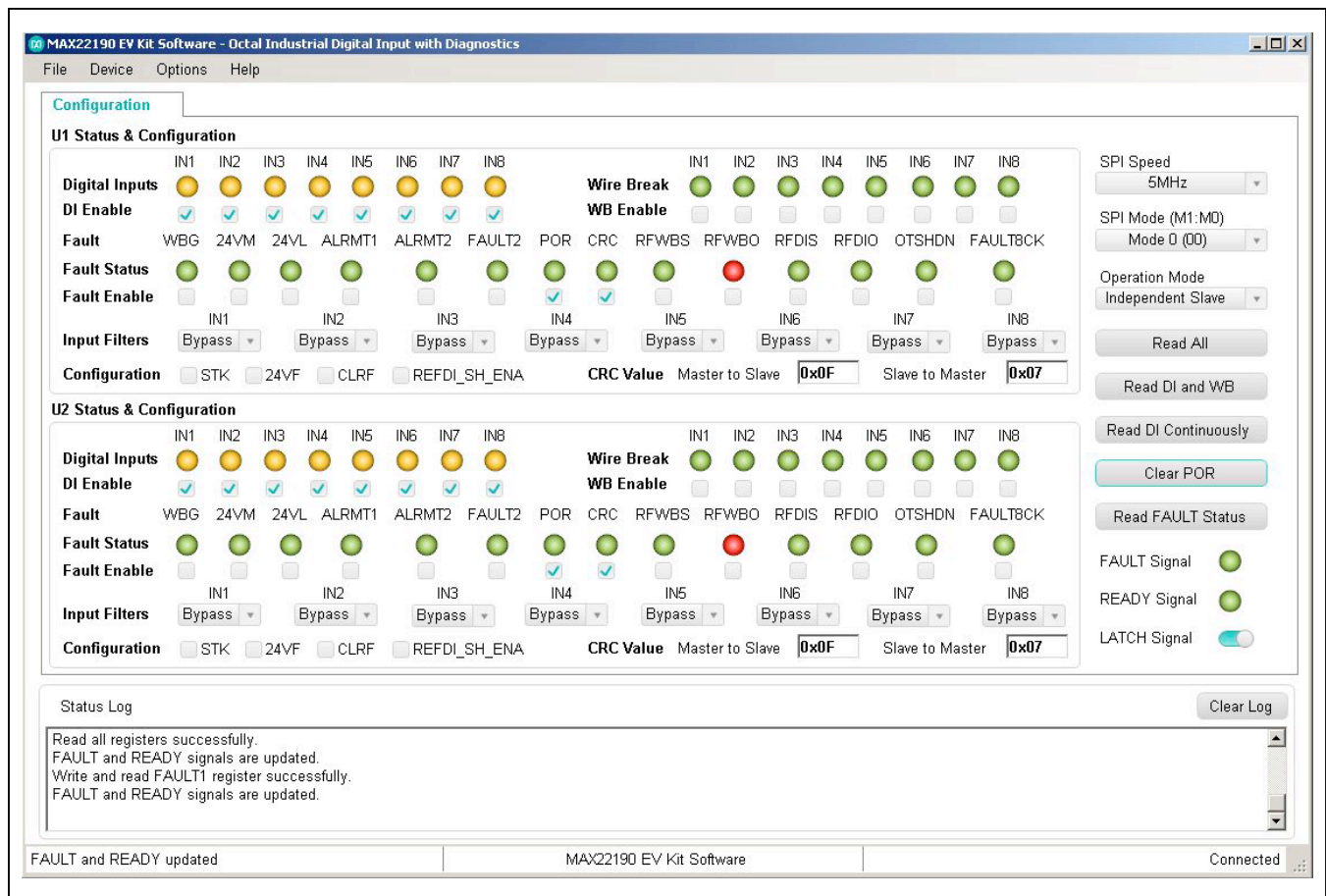

Figure 3. MAX22190 EV Kit Software—Clear POR

If the MAX22190EVKIT# hardware is not connected automatically, the **Device** menu provides the functions to connect or disconnect to the hardware by choosing detected USB2PMB2# serial numbers. Under the **Options** menu, a **CRC Calculator** (Figure 6) is provided to calculate the

5-bit CRC code based on the data frame provided by the user. The jumper positions are shown in the **Jumper Setting Diagram** (Figure 7) under **Options** menu based on selectable operation mode and SPI mode.

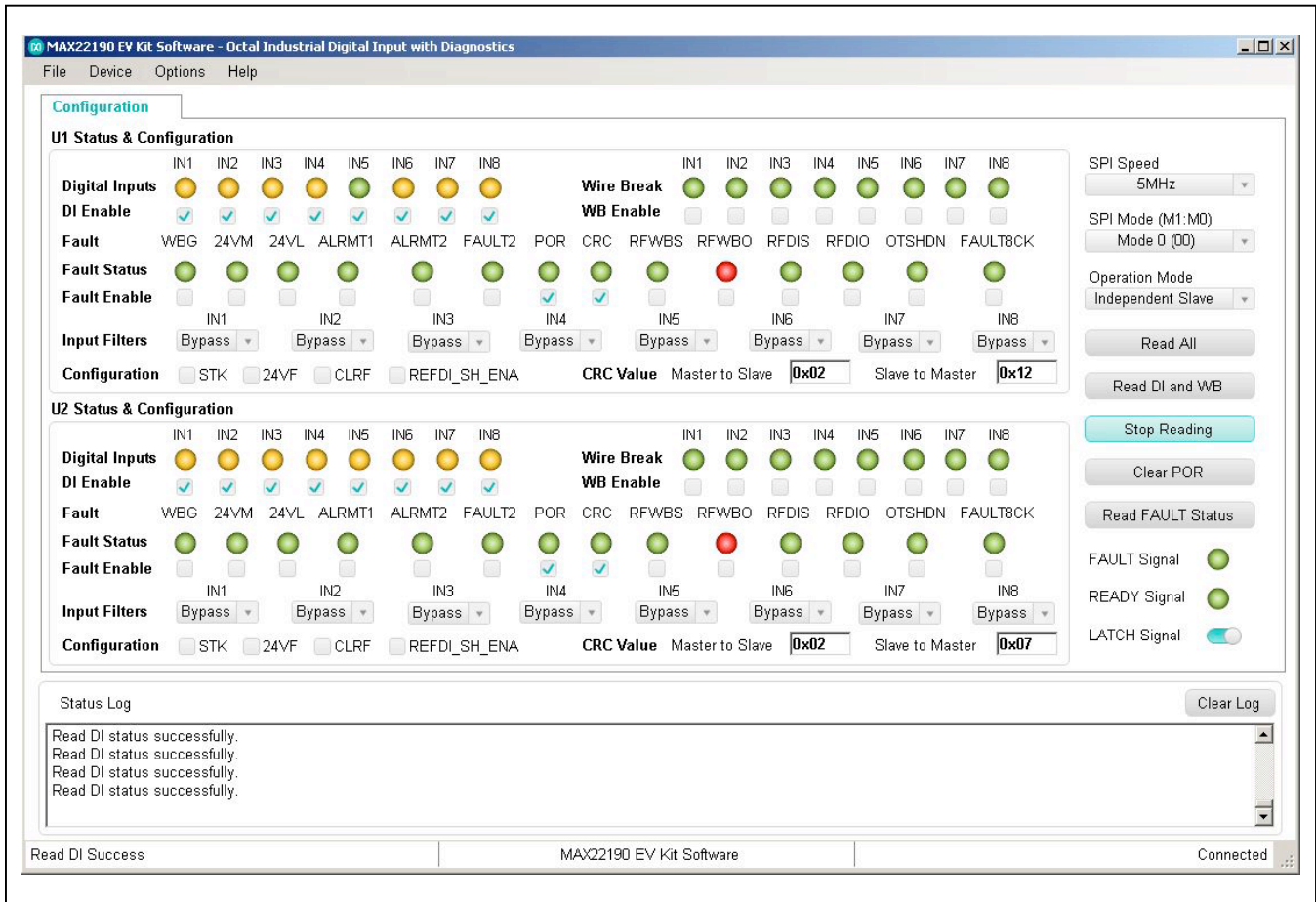

Figure 4. MAX22190 EV Kit Software—Read DI Continuously

Configuration Tab

The **Configuration** tab provides an interface for configuring the MAX22190 from a functional perspective. Before sending the commands to the MAX22190s, select desired Operation mode and SPI mode, and configure the jumpers according to the [Table 1](#). If Single Channel mode U1

is selected, all U2 controls are disabled ([Figure 5](#)), and vice-versa. The status and configuration box provides the controls for Digital Inputs reading, DI channel enable, Wire-Break status, Wire-Break enable, fault status reporting, FAULT pin configuration, input filter configuration, CRC value calculation, etc.

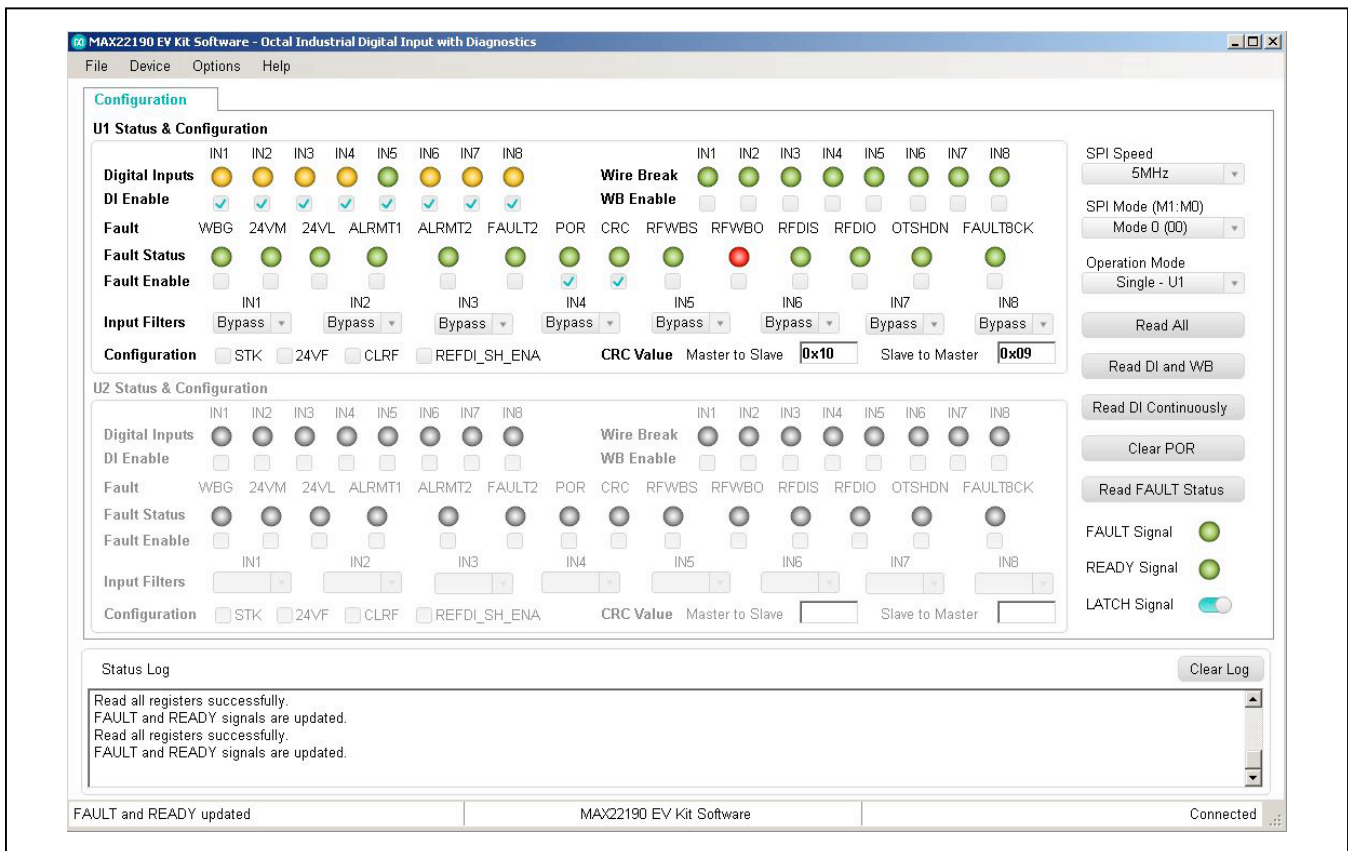

Figure 5. MAX22190 EV Kit Software—Single Channel Mode U1

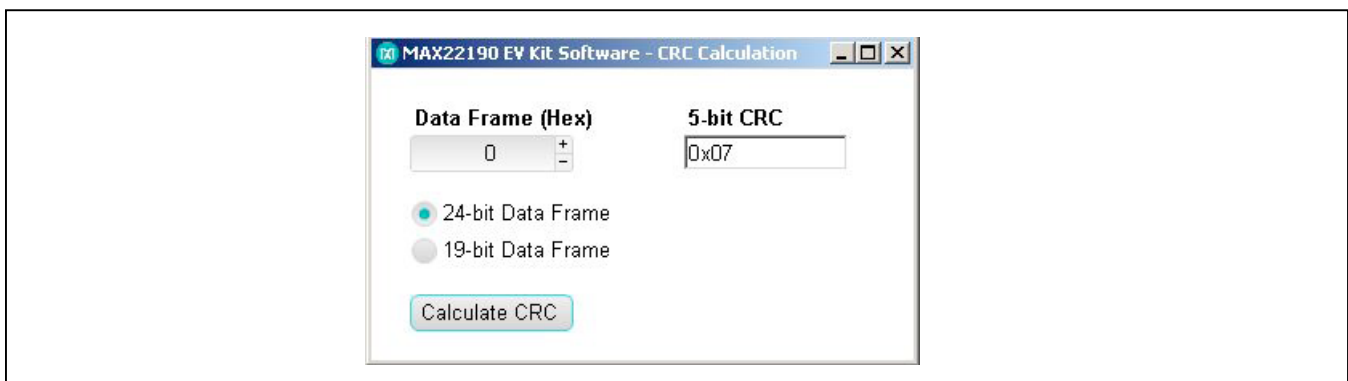

Figure 6. MAX22190 EV Kit Software—CRC Calculator

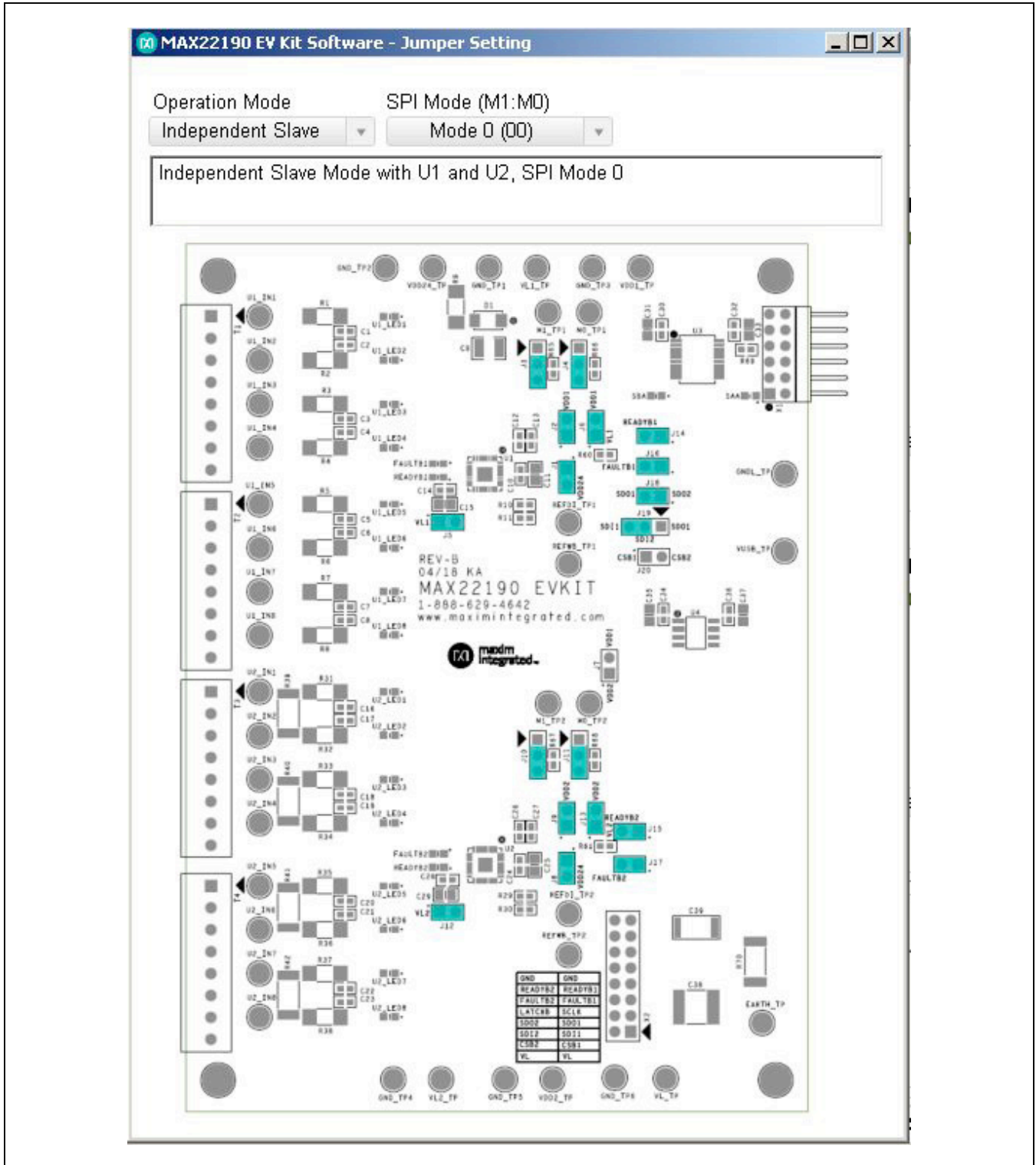

Figure 7. MAX22190 EV Kit Software—Jumper Setting Diagram

After power up, the MAX22190 $\overline{\text{FAULT}}$ pin is low and the POR bit in the FAULT1 register is set, indicating that a power-on-reset has happened and all registers are set to default (Figure 2). After clicking the **Clear POR** button, the GUI clears the POR bit in the FAULT1 register. The FAULT pin is pulled high and FAULTB1 or FAULTB2 LEDs are turned off after clearing the POR (Figure 3).

The **Read All** button reads the MAX22190 registers and refresh all the controls with current setting. The **Read DI and WB** and **Read DI Continuously** buttons read Digital Input and Wire Break registers value and update the corresponding controls. The **Read FAULT Status** button reads the FAULT1 and FAULT2 registers, polls OFAULT and SAA status and update the corresponding controls.

CRC Calculator

Clicking **CRC Calculator** under the **Options** menu will open the CRC calculation window (Figure 6). The software calculates the 5-bit CRC code based on the 19-bit data or 24-bit data (5 LSB bits are ignored) and display the result.

Jumper Setting Diagram

Clicking **Jumper Setting Diagram** under the **Options** menu will open the jumper setting window (Figure 7). The software displays the jumper position based on the current Operation mode and SPI mode in the top silkscreen diagram. Changing the Operation mode and SPI mode updates the shunt positions in the diagram. Please note that SPI mode should be set to Mode 0 or Mode 1 in Single Channel mode or Independent Slave mode, and set to Mode 2 or Mode 3 in Daisy-Chain mode. The Daisy-Chain mode is not implemented until software version 2.0.

Register Map

The **Register Map** tab shows all MAX22190 registers information including the register name, address, value, read or write accessibility, and the register description. The **Value** cell can be changed by user if the register is writable. By pressing the **Enter** key after changing the **Value** will write to the register. When certain register is highlighted in the register list, the bits' information in this register will be displayed in the **Bits Description** table. The bit **Setting** is configurable if the bit is writable, which will trigger a write operation to its register.

Clicking the **Read All** button reads all registers and refreshes the window with register settings. Clicking the **Write All** button writes the current settings to all registers.

The Register Map tab is not implemented until software version 2.0.

Detailed Description of Hardware

The MAX22190 EV kit provides a proven layout for a 16-input Galvanically Isolated Digital Input solution using two MAX22190s, and a MAX14483. Two MAX22190s are included with flexibility for operation modes making it easier to evaluate system performance of the MAX22190. This includes different SPI interface modes as well as support for all three types of IEC 61131-2 sensor inputs.

SPI Interface

The EV kit software communicates over USB to the SPI interface and supports full 10MHz clock rate for the MAX22190. The SPI interface can communicate to a single device, or both devices can be daisy-chained. Three SPI operation modes are supported by the EV kit: Single Channel mode, Independent Slave mode, and Daisy-Chain mode. Table 2 describes how to configure the EV kit jumpers to operate in different operation modes. The EV kit uses standard Pmod-compatible 12-pin header to connect to an external adapter board (USB2PMB2#) which provides an interface to a PC with an USB port. If the users wish to interface to their own Microcontroller or FPGA, simply hardwire the SPI signals to the Pmod connector X1.

Power Supplies

The EV kit has two power domains, the "logic side" which is powered from USB supplied power (VUSB and GNDL), and the "field side" which is typically powered from an external 24V DC supply connected to VDD24 and GND. MAX22190 has integrated regulator to provide low voltage output V_{DD} (3.3V, nominal) to power the field side of the digital isolators (VL). Alternatively, if an external 24V supply is not available, the field side can be powered using an external 3.0 - 5.5V supply through the VDD pin of the MAX22190 and leaving VDD24 pin floating (refer to Table 1 for jumper settings). The USB2PMB2# adapter board converts the USB 5V supply to a regulated +3.3V supply, which powers the EV kit logic side. Alternatively, if an external microcontroller is used, connect 3.0 - 5.5V external supply to test points VUSB_TP and GNDL_TP. The EV kit should be powered from two independent isolated power supplies to evaluate the galvanic isolation. For evaluating the electrical parameters of the device without any isolation between the two sides, a single dual-output power supply can also be used.

Type 1, 3 Inputs (U1)

The MAX22190 senses the state (high or low) of eight digital inputs. U1 is designed to support the trip points (voltage and current) to satisfy the requirements of IEC 61131-2 Type 1 and Type 3 inputs. Resistor R10 sets the current limit value at 2.35mA and input resistors R1-R8 set the voltage threshold to ensure compliance. The input resistors R1-R8 are 1.5k Ω , 1W MELF resistors to support IEC 61000-4-5 Surge Tolerance at ± 1 kV line-to-ground. A separate LED for each input port indicates the status of each input.

Type 2 Inputs (U2)

Type 2 inputs require higher current limits (6mA minimum) and U2 is configured to support four Type 2 Inputs by using two MAX22190 inputs in parallel. The current limit for each channel is set to a nominal 3.39mA through resistor R29. To set the correct voltage threshold, R31-R38 are 1k Ω , 1W MELF resistors. Resistors R39-R42 are 0 Ω to create a pair of inputs. By changing the value of the resistor R29, the current threshold can be set to a different value as desired. A separate LED for each input port indicates the status of the inputs.

Galvanic Isolation

The MAX22190 EV kit uses two digital isolators to provide galvanic isolation between the logic and field sides. The MAX14483 is a 6-channel digital isolator providing a single-chip solution when interfacing to a single MAX22190, or two MAX22190s connected in Daisy-Chain mode. The 2-channel MAX12931 is required in Independent Slave mode to isolate a second chip select (\overline{CS}) signal. Both isolators have two power supplies (VDDA and VDDDB) which operate between 1.71 - 5.5V and provide voltage

translation as well as galvanic isolation. The “logic side” VDDDB of each isolator is powered from VUSB and GNDL while the “field side” VDDA of each isolator is powered from VL and GND. The PCB layout ensures correct creepage and clearance rules are followed. Connector X2 is provided to allow easy probing of digital signals on the field side of the isolation barrier. When testing isolation performance, care should be taken not to have a multi-channel oscilloscope ground connection to both GND and GNDL.

Protective Earth is provided on the lower-right corner of the EV kit with safety rated Y capacitors between field ground (GND) and Earth (C38), and between field ground (GND) and logic ground (GNDL) (C39), to improve the high-voltage, fast transient performance.

IEC 61000-4 Immunity Compliance

The typical application for the MAX22190 requires it to pass basic transient immunity standards as defined by IEC 61000-4-x, covering -2 for Electrostatic Discharge (ESD), -4 for Electrical Fast Transient/Burst (EFT), and -5 for Surge Immunity. MAX22190 EV kit includes circuitry to support testing to these standards to support ± 2 kV Line-to-Line Surge, ± 8 kV Contact ESD, and ± 15 kV Air Gap ESD. MELF Resistor R9 and TVS D1 provide protection from Surge and ESD voltage applied through VDD24. C38 is a 3300pF safety rated Y capacitor placed between Protective Earth (PE) and field ground (GND) to improve transient immunity (EFT). C39 is a 1000pF safety rated Y capacitor connected between field ground and logic ground (GNDL) (across the isolation barrier). For systems where PE and GNDL are bonded together, the user can install the resistor R70. Both C39 and R70 are provided with the EV kit.

Ordering Information

PART	TYPE
MAX22190EVKIT#	EV Kit
MAX22190EVSYS#	EV System

#Denotes RoHS compliant.

The MAX22190EVSYS# includes the MAX22190EVKIT# and USB2PMB2#.

MAX22190 EV Kit Bill of Materials

ITEM	REF_DES	DNI/DNP	QTY	MFG PART #	MANUFACTURER	VALUE	DESCRIPTION	COMMENTS
1	C10, C12, C14, C24, C26, C28, C30, C32, C34, C36	-	10	CC0603KRX7ROBB104	YAGEO	0.1UF	CAPACITOR; SMT (0603); CERAMIC CHIP; 0.1UF; 100V; TOL=10%; TG=-55 DEGC TO +125 DEGC; TC=X7R	
2	C11, C15, C25, C29	-	4	C2012X752A105K125; GRJ21BC72A105KE11	TDK;MURATA	1UF	CAPACITOR; SMT (0805); CERAMIC CHIP; 1UF; 100V; TOL=10%; TG=-55 DEGC TO +125 DEGC; TC=X7S	
3	C13, C27	-	2	UMK107AB7105KA	TAIYO YUDEN	1UF	CAPACITOR; SMT (0603); CERAMIC CHIP; 1UF; 50V; TOL=10%; TG=-55 DEGC TO +125 DEGC; TC=X7R	
4	C31, C33, C35, C37	-	4	GRM21BZ71E106KE15	MURATA	10UF	CAPACITOR; SMT (0805); CERAMIC CHIP; 10UF; 25V; TOL=10%; TG=-55 DEGC TO +125 DEGC; TC=X7R	
5	C39	-	1	GA352QR7GF102KW01	MURATA	1000PF	CAP; SMT (2211); 1000PF; 10%; 250V; X7R; CERAMIC CHIP	
6	D1	-	1	SMAJ33CA	VISHAY GENERAL SEMICONDUCTOR	33V	DIODE; TVS; SMA (DO-214AC); VRM=33V; IPP=7.5A	
7	EARTH_TP	-	1	5012	KEYSTONE	N/A	TEST POINT; PIN DIA=0.125IN; TOTAL LENGTH=0.445IN; BOARD HOLE=0.063IN; WHITE; PHOSPHOR BRONZE WIRE SILVER PLATE FINISH;	
8	FAULTB1, FAULTB2	-	2	LTST-C193KRKT-2A	LITE-ON ELECTRONICS INC.	LTST-C193KRKT-2A	DIODE; LED; EXTRA THIN; EXTRA BRIGHT; RED; SMT (0603); VF=2.2V; IF=0.002A	
9	GNDL_TP, GND_TP1-GND_TP6	-	7	5011	KEYSTONE	N/A	TEST POINT; PIN DIA=0.125IN; TOTAL LENGTH=0.445IN; BOARD HOLE=0.063IN; BLACK; PHOSPHOR BRONZE WIRE SILVER PLATE FINISH;	
10	J1, J2, J5-J9, J12-J18, J20	-	15	PEC02SAAN	SULLINS	PEC02SAAN	CONNECTOR; MALE; THROUGH HOLE; BREAKAWAY; STRAIGHT; 2PINS	
11	J3, J4, J10, J11, J19	-	5	PEC03SAAN	SULLINS ELECTRONICS CORP.	PEC03SAAN	EVKIT PART-CONNECTOR; MALE; THROUGH HOLE; BREAKAWAY; STRAIGHT; 3PINS; -65 DEGC TO +125 DEGC;	
12	M0_TP1, M0_TP2, M1_TP1, M1_TP2, REFDL_TP1, REFDL_TP2, REFVB_TP1, REFVB_TP2	-	8	5014	KEYSTONE	N/A	TEST POINT; PIN DIA=0.125IN; TOTAL LENGTH=0.445IN; BOARD HOLE=0.063IN; YELLOW; PHOSPHOR BRONZE WIRE SILVER PLATE FINISH;	
13	R1-R8	-	8	CMB02070X1501G	VISHAY BEYSCHLAG	1.5K	RESISTOR; SMT; 1.5K OHM; 2%; 1W; CARBON FILM	
14	R9	-	1	CMB02070X1500G	VISHAY BEYSCHLAG	150	RES; SMT; 150; 2%; 1W	
15	R10	-	1	ERJ-3EKF7501V	PANASONIC	7.5K	RESISTOR; 0603; 7.5K OHM; 1%; 100PPM; 0.10W; THICK FILM	
16	R11, R30	-	2	ERJ-3EKF2402V	PANASONIC	24K	RESISTOR; 0603; 24K OHM; 1%; 100PPM; 0.10W; THICK FILM	
17	R12, R13, R43, R44, R62-R64, R69	-	8	CRG0603F10K	TE CONNECTIVITY	10K	RESISTOR; 0603; 10K OHM; 1%; 100PPM; 0.1W; THICK FILM	
18	R14-R20, R45-R51, R65-R68	-	18	CRCW060320R0FK; ERJ-3EKF20R0V	VISHAY DALE; PANASONIC	20	RESISTOR, 0603, 20 OHM, 1%, 100PPM, 0.10W, THICK FILM	
19	R29	-	1	CRCW06035K23FK	VISHAY DALE	5.23K	RESISTOR; 0603; 5.23K OHM; 1%; 100PPM; 0.10W; THICK FILM	
20	R31-R38	-	8	CMB02070X1001G	VISHAY BEYSCHLAG	1K	RESISTOR; SMT; 1K OHM; 2%; 250PPM; 1.0W; CARBON FILM	

MAX22190 EV Kit Bill of Materials (continued)

ITEM	REF_DES	DNI/DNP	QTY	MFG PART #	MANUFACTURER	VALUE	DESCRIPTION	COMMENTS
21	R39-R42	-	4	CRCW25120000Z0EGHP	VISHAY DRALORIC	0	RES; SMT (2512); 0; JUMPER; 1.5W	
22	R60, R61	-	2	CRCW060349R9FK	VISHAY DALE	49.9	RESISTOR; 0603; 49.9 OHM; 1%; 100PPM; 0.10W; THICK FILM	
23	READYB1, READYB2, SAA, SBA	-	4	LTST-C193KSKT-5A	LITE-ON ELECTRONICS INC.	LTST-C193KSKT-5A	DIODE; LED; YELLOW; SMT (0603); VF=2V; IF=0.005A	
24	SU1-SU20	-	20	STC02SYAN	SULLINS ELECTRONICS CORP.	STC02SYAN	TEST POINT; JUMPER; STR; TOTAL LENGTH=0.256IN; BLACK; INSULATION=PBT CONTACT=PHOSPHOR BRONZE; COPPER PLATED TIN OVERALL	
25	T1-T4	-	4	1984675	PHOENIX CONTACT	1984675	CONNECTOR; FEMALE; THROUGH HOLE; PCB TERMINAL BLOCK; RIGHT ANGLE; 8PINS	
26	U1, U2	-	2	MAX22190ATJ+	MAXIM INTEGRATED	MAX22190ATJ+	EVKIT PART-IC; OCTAL INDUSTRIAL DIGITAL INPUT WITH DIAGNOSTICS; PACKAGE OUTLINE: 21-0140; PACKAGE CODE: T3255+6; LAND PATTERN NO.: 90-0603; TQFN32-EP	
27	U1_IN1-U1_IN8, U2_IN1-U2_IN8	-	16	5125	KEYSTONE	N/A	TEST POINT; PIN DIA=0.125IN; TOTAL LENGTH=0.445IN; BOARD HOLE=0.063IN; BROWN; PHOSPHOR BRONZE WIRE SILVER PLATE FINISH;	
28	U1_LED1-U1_LED8, U2_LED1-U2_LED8	-	16	LTST-C193KGKT-5A	LITE-ON ELECTRONICS INC.	LTST-C193KGKT-5A	DIODE; LED; STANDARD; YELLOW-GREEN; SMT (0603); PIV=1.9V; IF=0.005A; -55 DEGC TO +85 DEGC	
29	U3	-	1	MAX14483AAP+	MAXIM	MAX14483AAP+	EVKIT PART - IC; MAX14483AAP+; 8-CHANNEL; LOW POWER; 3.75KVRMS; SPI DIGITAL ISOLATOR; PACKAGE OUTLINE DRAWING: 21-0056; LAND PATTERN: 90-0094	
30	U4	-	1	MAX12931BASA+	MAXIM	MAX12931BASA+	EVKIT PART - IC; DISO; 1/1 CHANNEL; 25MBPS; DEFAULT HIGH; 3.75KVRMS DIGITAL ISOLATOR; NSOIC8	
31	VDD1_TP, VDD2_TP, VDD24_TP, VL1_TP, VL2_TP, VL_TP, VUSB_TP	-	7	5013	KEYSTONE	N/A	TEST POINT; PIN DIA=0.125IN; TOTAL LENGTH=0.445IN; BOARD HOLE=0.063IN; ORANGE; PHOSPHOR BRONZE WIRE SILVER PLATE FINISH;	
32	X1	-	1	TSW-106-08-S-D-RA	SAMTEC	TSW-106-08-S-D-RA	CONNECTOR; THROUGH HOLE; DOUBLE ROW; RIGHT ANGLE; 12PINS;	
33	X2	-	1	PBC08DAAN	SULLINS ELECTRONICS CORP.	PBC08DAAN	CONNECTOR; MALE; THROUGH HOLE; BREAKAWAY; STRAIGHT; 16PINS; -65 DEGC TO +125 DEGC	
34	PCB	-	1	MAX22190	MAXIM	PCB	PCB:MAX22190	-
35	MTH1-MTH4	DNI	4	1902B	GENERIC PART	N/A	STANDOFF; FEMALE-THREADED; HEX; 4-40IN; 3/8IN; NYLON	
36	MTH1-MTH4	DNI	4	P440.375	GENERIC PART	N/A	MACHINE SCREW; SLOTTED; PAN; 4-40IN; 3/8IN; NYLON	
37	C9	DNI	1	GRM32EC72A106KE05	MURATA	10UF	CAPACITOR; SMT (1210); CERAMIC CHIP; 10UF; 100V; TOL=10%; TG=-55 DEGC TO +125 DEGC; TC=X75	
38	C38	DNI	1	VJ2220Y332KXUSTX1	VISHAY VITRAMON	3300PF	CAP; SMT (2220); 3300PF; 10%; 250V; X7R; CERAMIC CHIP	
39	R70	DNI	1	CRCW25120000Z0EGHP	VISHAY DRALORIC	0	RES; SMT (2512); 0; JUMPER; 1.5W	
40	C1-C8, C16-C23	DNP	0	C1608C0G2A102J080AA	TDK	1000PF	CAPACITOR; SMT (0603); CERAMIC CHIP; 1000PF; 100V; TOL=5%; TG=-55 DEGC TO +125 DEGC; TC=C0G	
41	R21-R28, R52-R59	DNP	0	CRCW06030000Z0	VISHAY DALE	0	RESISTOR; 0603; 0 OHM; 0%; JUMPER; 0.1W; THICK FILM	
TOTAL			198					

MAX22190 EV Kit Schematics (continued)

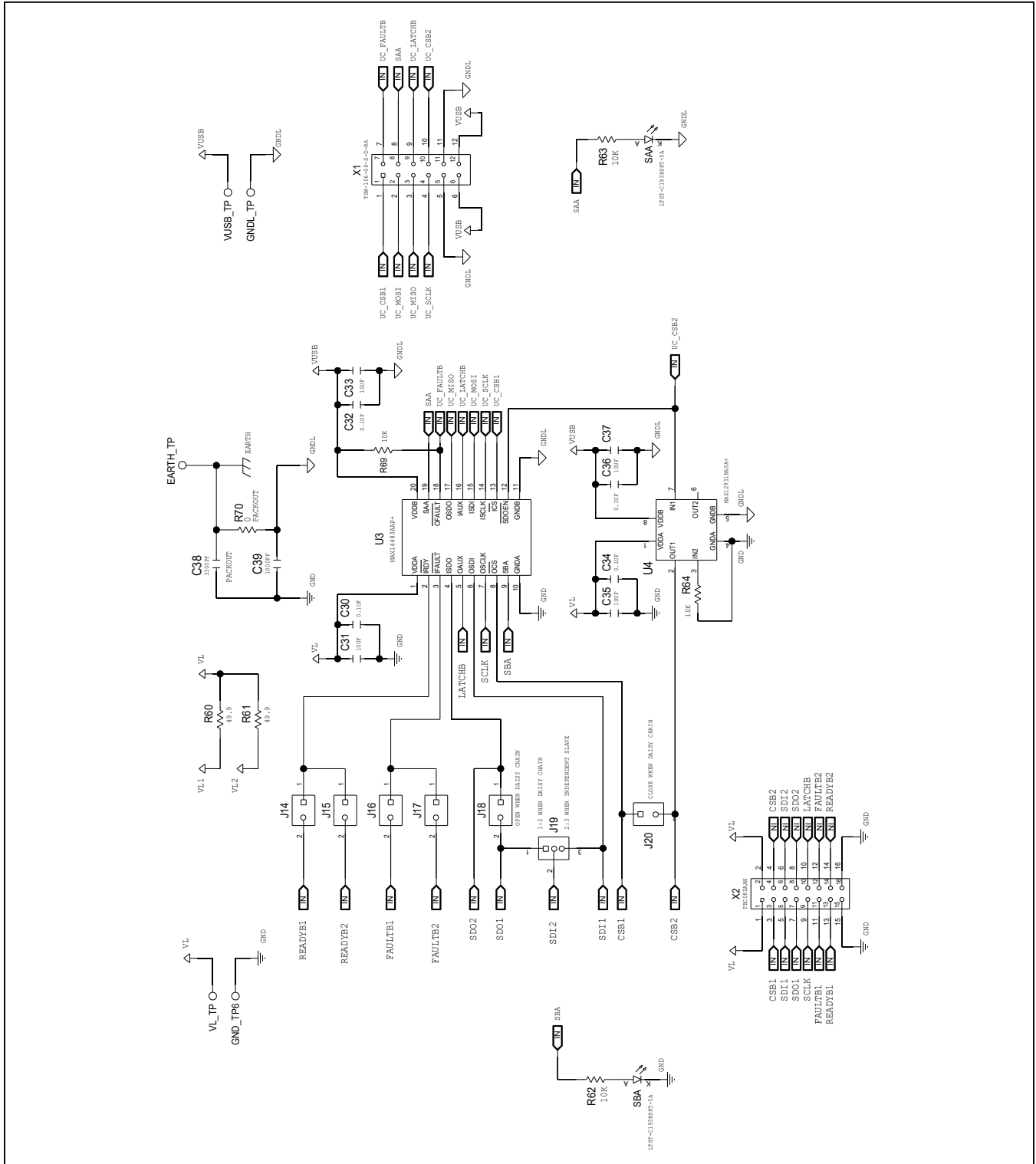

MAX22190 EV Kit PCB Layout

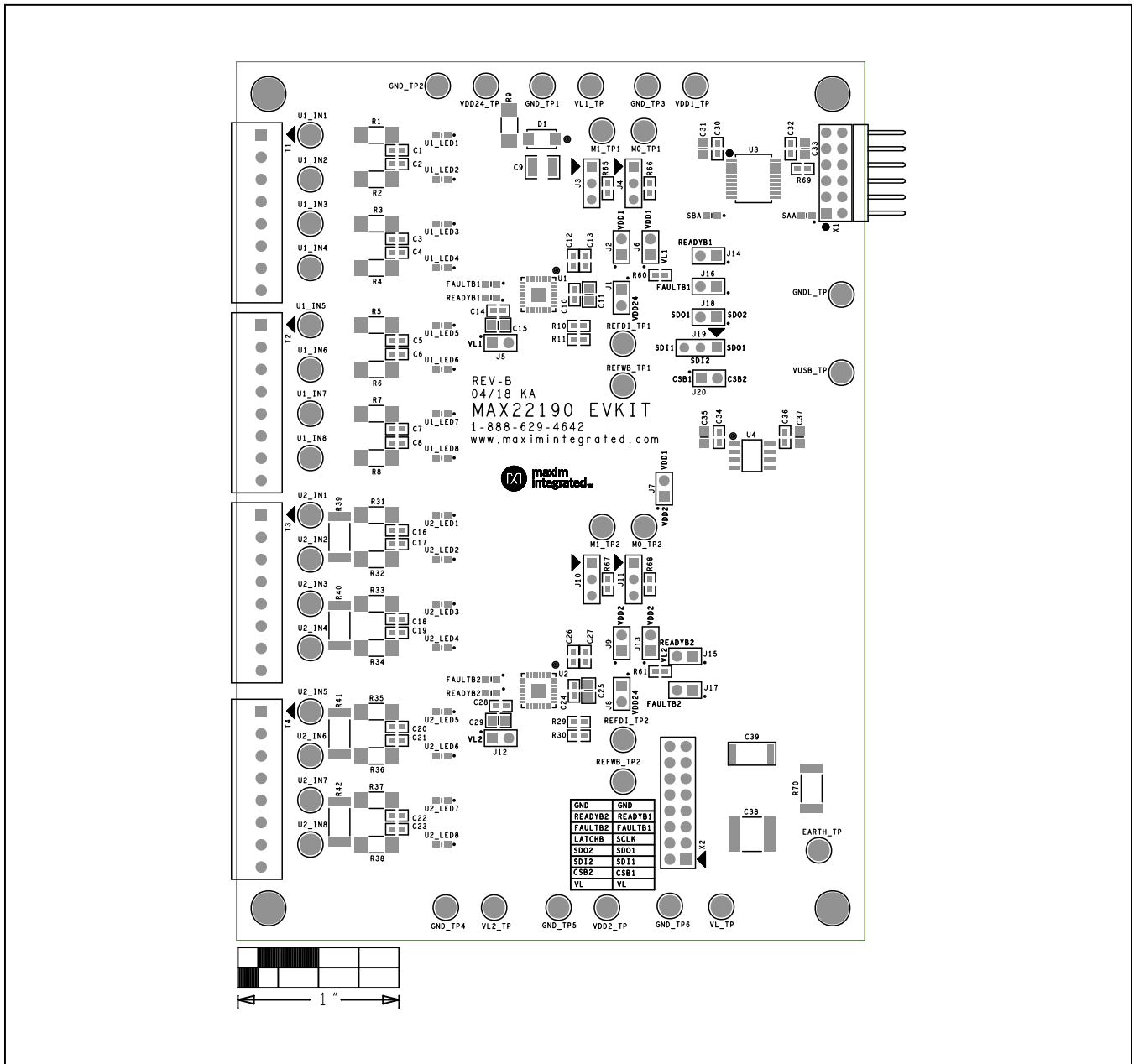

MAX22190 EV Kit—Top Silkscreen

MAX22190 EV Kit PCB Layout (continued)

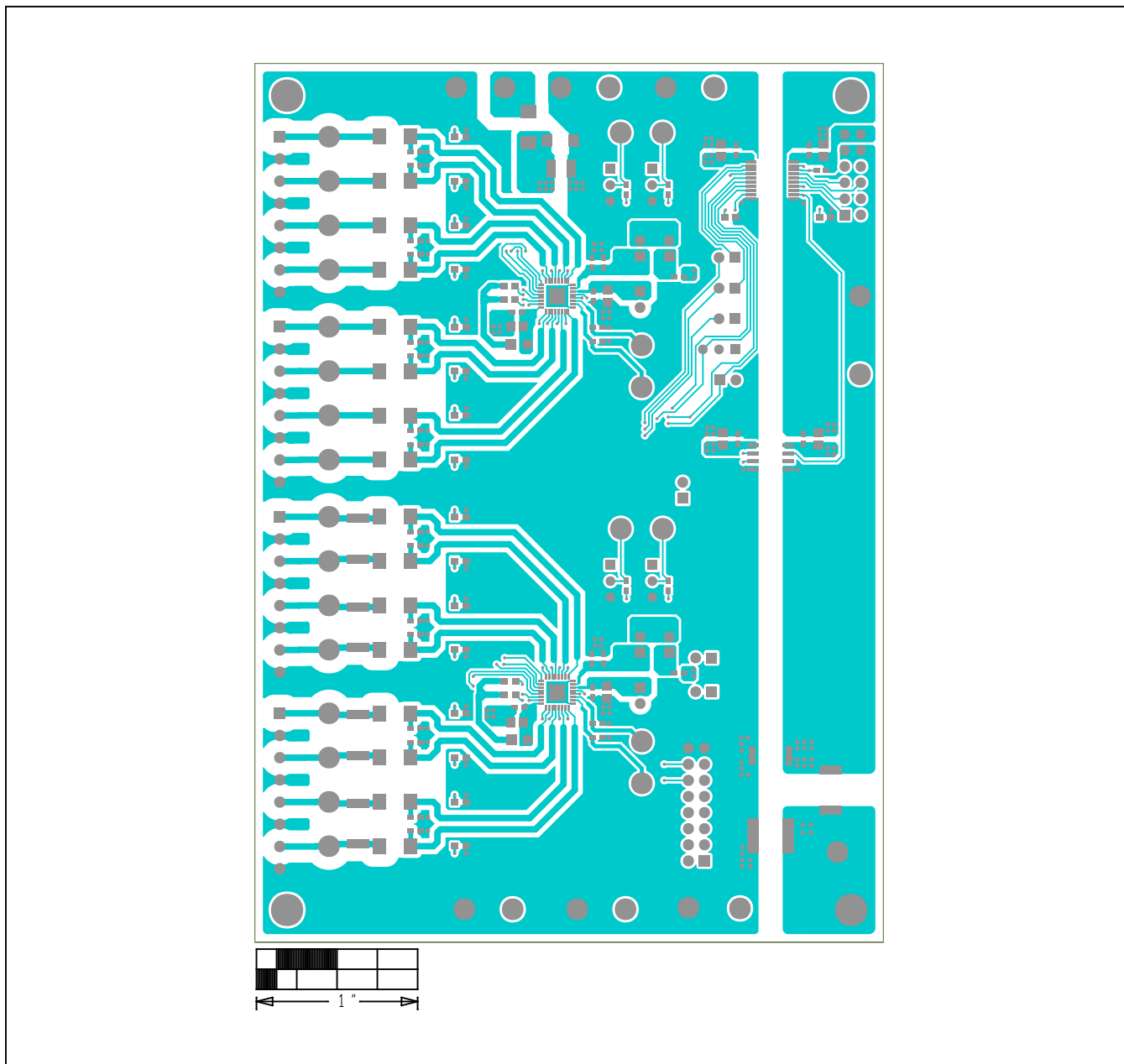

MAX22190 EV Kit—Top

MAX22190 EV Kit PCB Layout (continued)

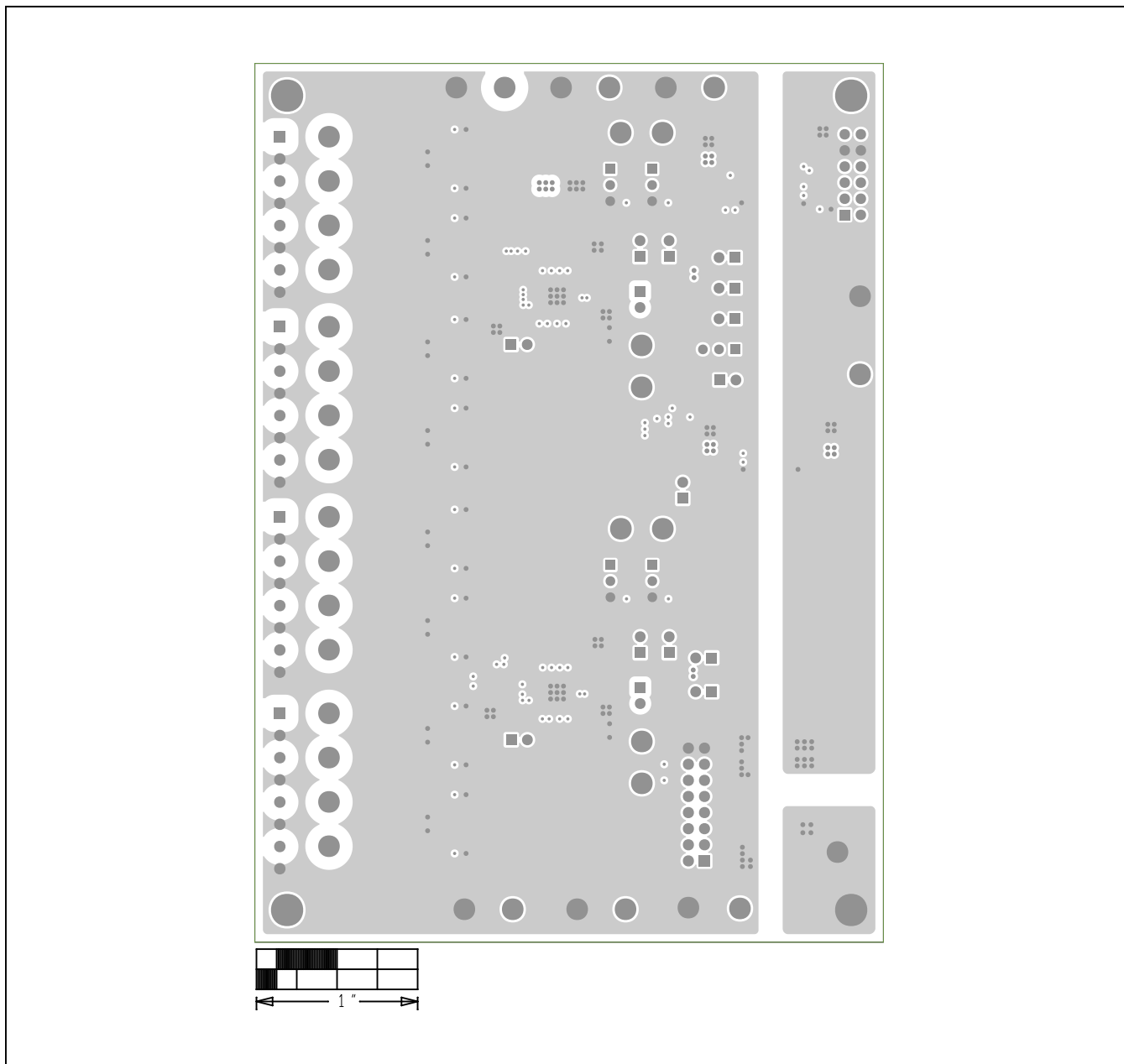

MAX22190 EV Kit—Internal 2

MAX22190 EV Kit PCB Layout (continued)

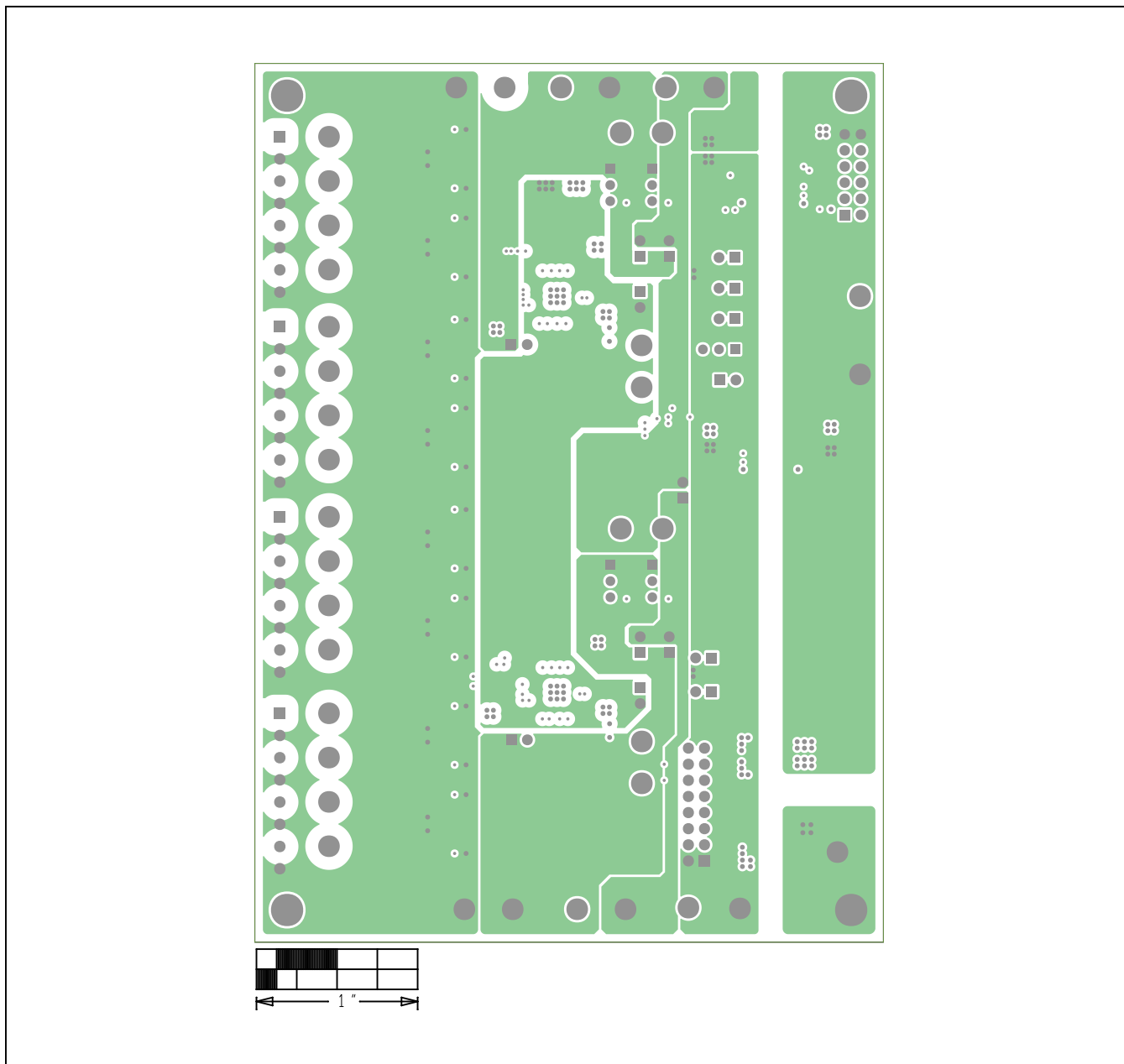

MAX22190 EV Kit—Internal 3

MAX22190 EV Kit PCB Layout (continued)

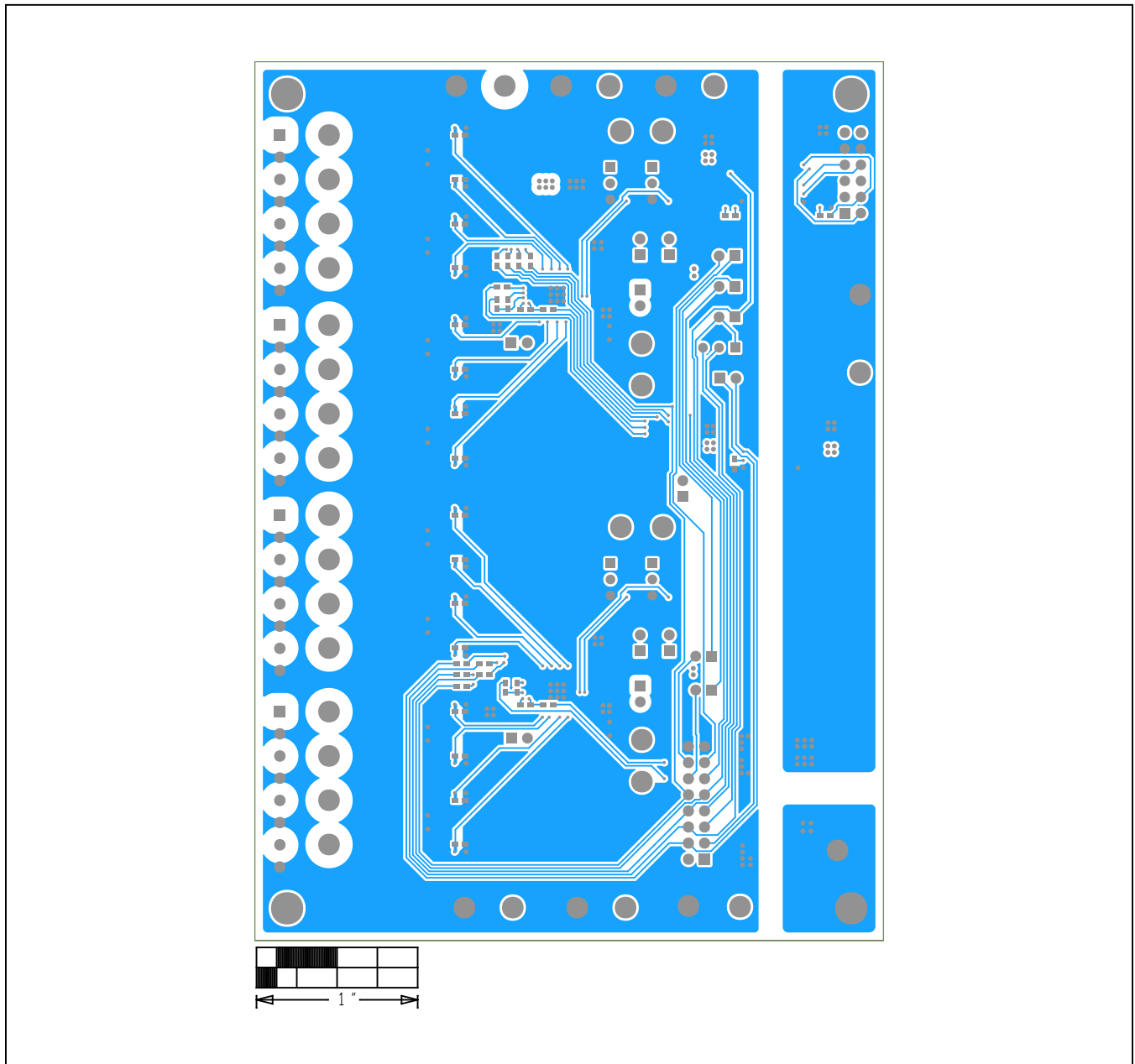

MAX22190 EV Kit—Bottom

Revision History

REVISION NUMBER	REVISION DATE	DESCRIPTION	PAGES CHANGED
0	6/18	Initial release	—

For pricing, delivery, and ordering information, please contact Maxim Direct at 1-888-629-4642, or visit Maxim Integrated's website at www.maximintegrated.com.

Maxim Integrated cannot assume responsibility for use of any circuitry other than circuitry entirely embodied in a Maxim Integrated product. No circuit patent licenses are implied. Maxim Integrated reserves the right to change the circuitry and specifications without notice at any time.