

| CODE No. | CONTACT | A | B | C | D | E | F |
|-----------------|---------|------|------|------|------|------|------|
| CL537-0428-5-81 | 20 | 7.2 | 4.5 | 5.3 | 5.7 | 6.6 | 5.3 |
| CL537-0430-7-81 | 30 | 9.7 | 7.0 | 7.8 | 8.2 | 9.1 | 7.8 |
| CL537-0431-0-81 | 36 | 11.2 | 8.5 | 9.3 | 9.7 | 10.6 | 9.3 |
| CL537-0432-2-81 | 40 | 12.2 | 9.5 | 10.3 | 10.7 | 11.6 | 10.3 |
| CL537-0434-8-81 | 50 | 14.7 | 12.0 | 12.8 | 13.2 | 14.1 | 12.8 |
| CL537-0436-3-81 | 60 | 17.2 | 14.5 | 15.3 | 15.7 | 16.6 | 15.3 |

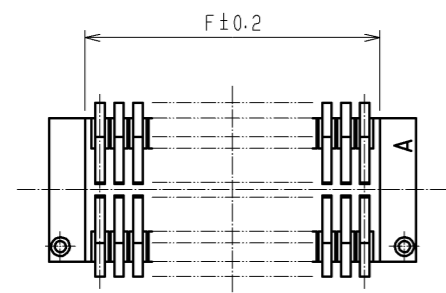

RECOMMEND METAL MASK PATTERN (10:1)

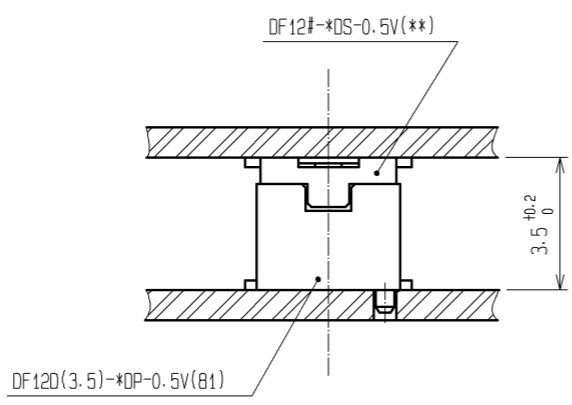
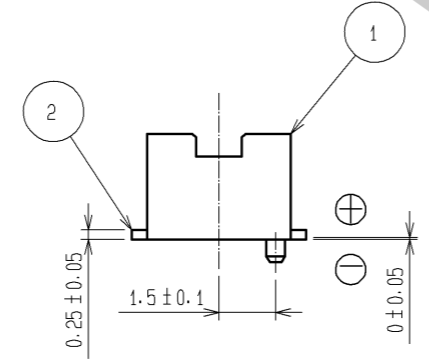
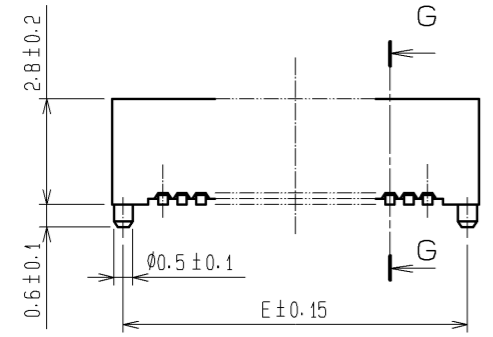
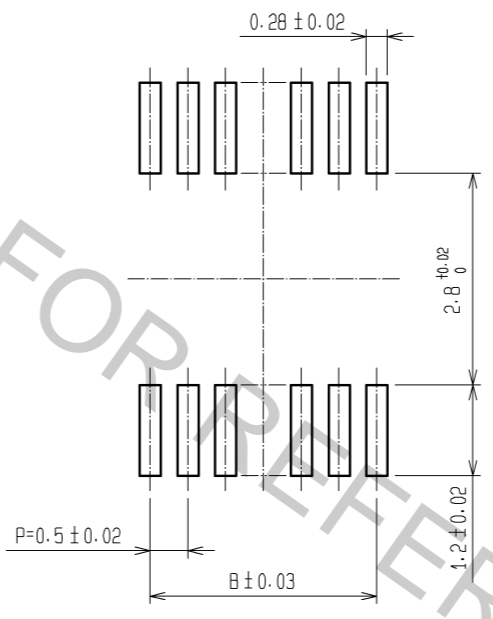

RECOMMENDED THICKNESS OF METAL MASK : 120 μm

RECOMMENDED LAND PATTERN (10:1)

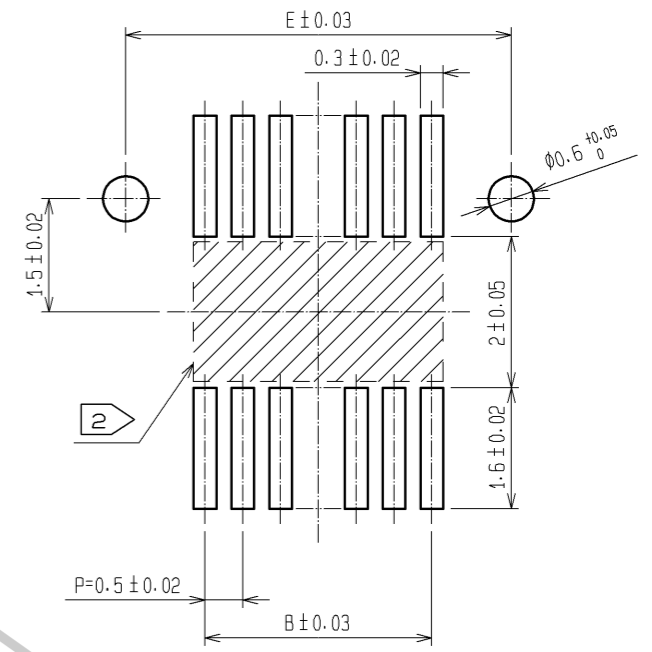

RECOMMENDED THICKNESS OF SOLDER PASTE : 120 μm

NOTES 1 LEAD CO-PLANARITY SHALL BE 0.08 mm MAX.
 2 IF THERE IS PATTERN ON [Hatched] PART, THERE IS A POSSIBILITY THAT IT WILL MAKE CONTACT WITH THE LEADS.

| NO. | MATERIAL | FINISH | REMARKS | NO. | MATERIAL | FINISH | REMARKS |
|-----|-----------------|--------|--|-----|-----------|--------|-------------------------------|
| 2 | PHOSPHOR BRONZE | | CONTACT AREA:GOLD PLATED 0.2μm min LEAD AREA:GOLD PLATED 0.015μm min OTHERS(UNDER PLATING):NICKEL PLATED 2μm min | 6 | PS | | CLEAR (REINFORCEMENT COLLAR) |
| | | | | 5 | PS | | BLACK (PLASTIC REEL) |
| | | | | 4 | POLYESTER | | CLEAR (COVER TAPE) |
| 1 | POLYAMIDE | | UL94V-0, NATURAL (BEIGE) | 3 | PS | | CLEAR (EMBOSSED CARRIER TAPE) |

| UNITS | SCALE | COUNT | DESCRIPTION OF REVISIONS | DESIGNED | CHECKED | DATE |
|-------------------------|-------|-------|--------------------------|----------------------------------|---------|------|
| mm | 5 : 1 | △ | | | | |
| APPROVED : KH. IKEDA | | | 13.08.19 | DRAWING NO. EDC3-162287-77 | | |
| CHECKED : YH. MICHIDA | | | 13.08.09 | PART NO. DF12D(3.5)-*DP-0.5V(81) | | |
| DESIGNED : YN. SAKAMOTO | | | 13.08.08 | CODE NO. CL537 | | |
| DRAWN : KR. AJITO | | | 13.08.08 | | | |

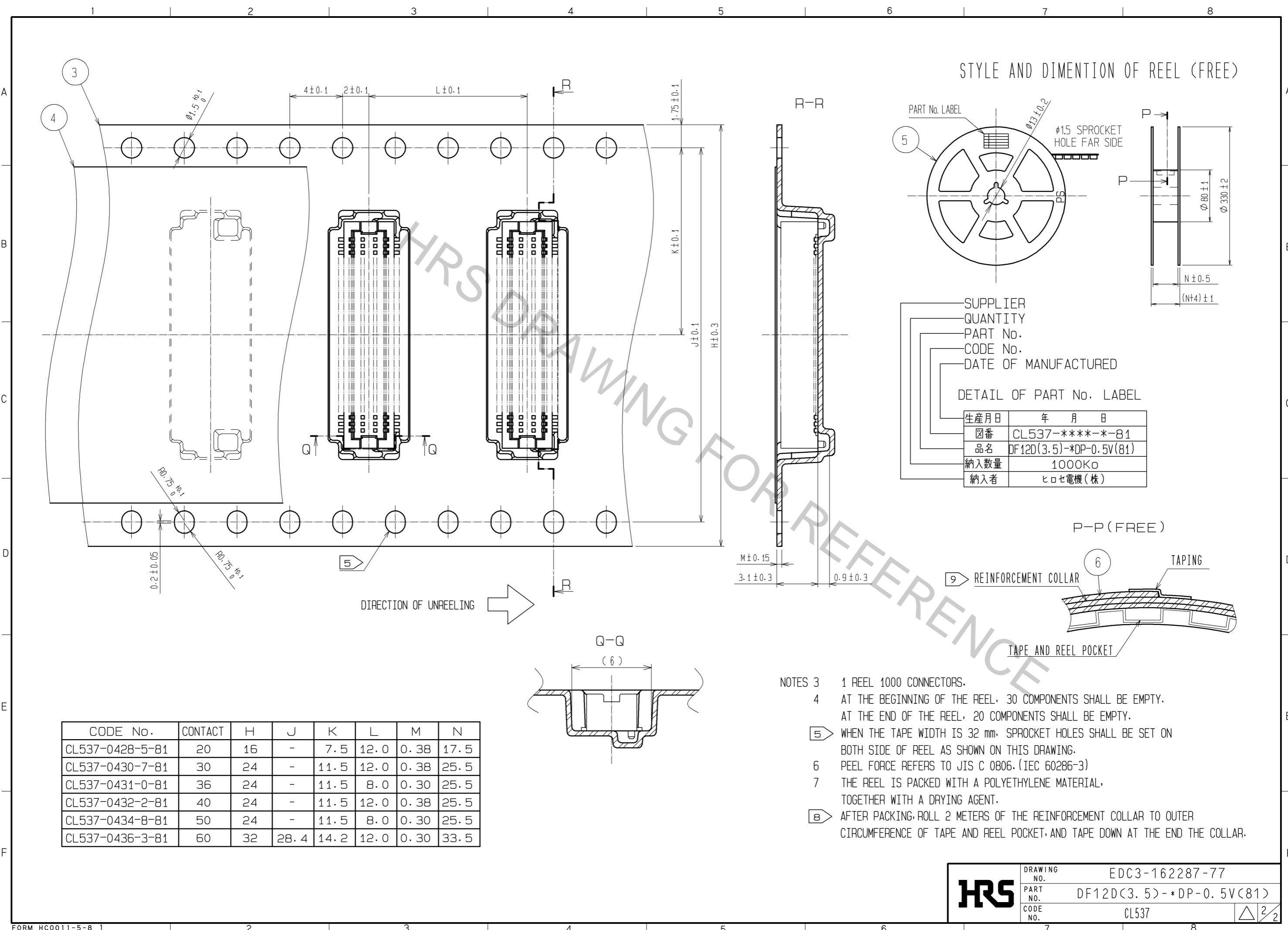

STYLE AND DIMENTION OF REEL (FREE)

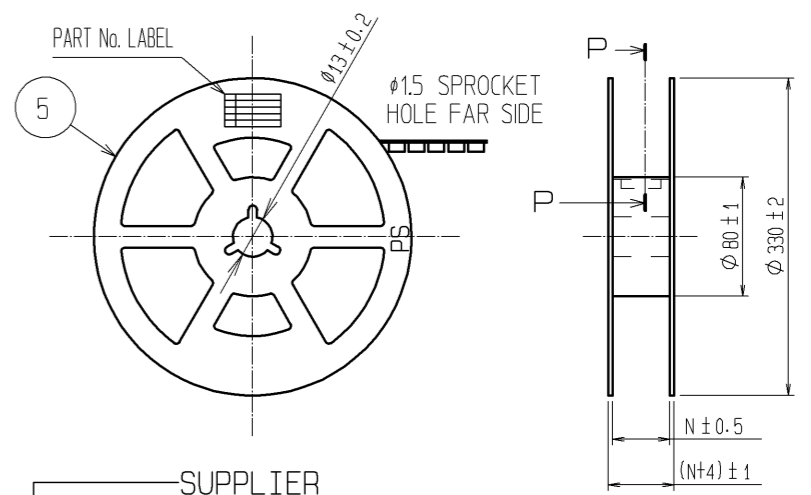

SUPPLIER
 QUANTITY
 PART No.
 CODE No.
 DATE OF MANUFACTURED

DETAIL OF PART No. LABEL

| | |
|------|-------------------------|
| 生産月日 | 年 月 日 |
| 図番 | CL537-****-*-81 |
| 品名 | DF12D(3.5)-*DP-0.5V(81) |
| 納入数量 | 1000K0 |
| 納入者 | ヒロセ電機(株) |

P-P (FREE)

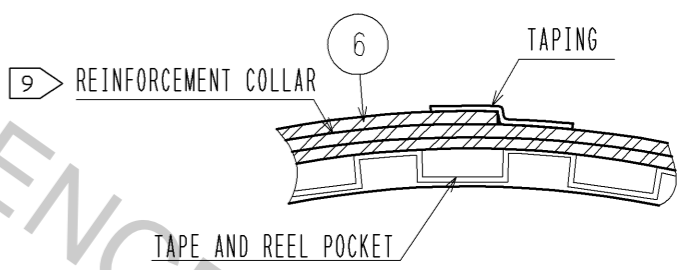

| CODE No. | CONTACT | H | J | K | L | M | N |
|-----------------|---------|----|------|------|------|------|------|
| CL537-0428-5-81 | 20 | 16 | - | 7.5 | 12.0 | 0.38 | 17.5 |
| CL537-0430-7-81 | 30 | 24 | - | 11.5 | 12.0 | 0.38 | 25.5 |
| CL537-0431-0-81 | 36 | 24 | - | 11.5 | 8.0 | 0.30 | 25.5 |
| CL537-0432-2-81 | 40 | 24 | - | 11.5 | 12.0 | 0.38 | 25.5 |
| CL537-0434-8-81 | 50 | 24 | - | 11.5 | 8.0 | 0.30 | 25.5 |
| CL537-0436-3-81 | 60 | 32 | 28.4 | 14.2 | 12.0 | 0.30 | 33.5 |

- NOTES 3 1 REEL 1000 CONNECTORS.
 4 AT THE BEGINNING OF THE REEL, 30 COMPONENTS SHALL BE EMPTY.
 AT THE END OF THE REEL, 20 COMPONENTS SHALL BE EMPTY.
 5 WHEN THE TAPE WIDTH IS 32 mm, SPROCKET HOLES SHALL BE SET ON BOTH SIDE OF REEL AS SHOWN ON THIS DRAWING.
 6 PEEL FORCE REFERS TO JIS C 0806. (IEC 60286-3)
 7 THE REEL IS PACKED WITH A POLYETHYLENE MATERIAL, TOGETHER WITH A DRYING AGENT.
 8 AFTER PACKING, ROLL 2 METERS OF THE REINFORCEMENT COLLAR TO OUTER CIRCUMFERENCE OF TAPE AND REEL POCKET, AND TAPE DOWN AT THE END THE COLLAR.

| | | |
|------------|-------------|-------------------------|
| HRS | DRAWING NO. | EDC3-162287-77 |
| | PART NO. | DF12D(3.5)-*DP-0.5V(81) |
| | CODE NO. | CL537 |
| | | △ 2/2 |