

SECT. "Z-Z"

NOTES:

1. MATERIAL: SEE TABLE
2. FINISHES: SEE TABLE
3. PRODUCT SPECIFICATION: NOT REQUIRED
4. PACKAGING: NOT REQUIRED
5. MATES WITH: 90 SERIES PLUG
6. "XX" REFERS TO THE NUMBER OF CIRCUITS.
7. SEE DWG SD-38120-003 FOR PRINTING OPTIONS.

ITEM	QTY.	DESCRIPTION	MATERIAL	FINISH
2	XX	HEADER PIN	BRASS	TIN PLATE
1	1	HEADER	PBT	SEE TABLE

EC NO. 4105 DRWN: GHR 5-2-05 CHK: K APPR: C	DESCRIPTION MAJOR CRITICAL SPC	REV
------------------------------------------------------	-----------------------------------------	-----

QUALITY SYMBOLS		GENERAL TOLERANCES: (UNLESS SPECIFIED)	
4 PLACES	mm	INCH	±.0015
3 PLACES	±.038	±.005	
2 PLACES	±.13	±.01	
1 PLACE	±.3		
ANGULAR: ±2°		DRAFT WHERE APPLICABLE MUST REMAIN WITHIN DIMENSIONS	

SCALE 3:1	DESIGN UNITS <input type="checkbox"/> mm <input checked="" type="checkbox"/> INCH
DRAWN BY & DATE W. HOWARD 10-9-03	
CHECKED BY & DATE L.ROTHAUS 10-9-03	
APPROVED BY & DATE L.ROTHAUS 10-9-03	
CAD FILENAME 9016XX	MATERIAL NO. SEE TABLE

PROJECT NO. -	SHT -	REV -
DIMENSIONS: <input checked="" type="checkbox"/> mm <input type="checkbox"/> INCH		REVISION ON CAD ONLY
TITLE: HEADER, VERTICAL 3.81 (.150)		
MOLEX INCORPORATED		
DRAWING NO. SD-39900-001	SHEET NO. 1 OF 2	
THIS DRAWING CONTAINS INFORMATION THAT IS PROPRIETARY TO MOLEX INCORPORATED AND SHOULD NOT BE USED WITHOUT WRITTEN PERMISSION.		
		SIZE B

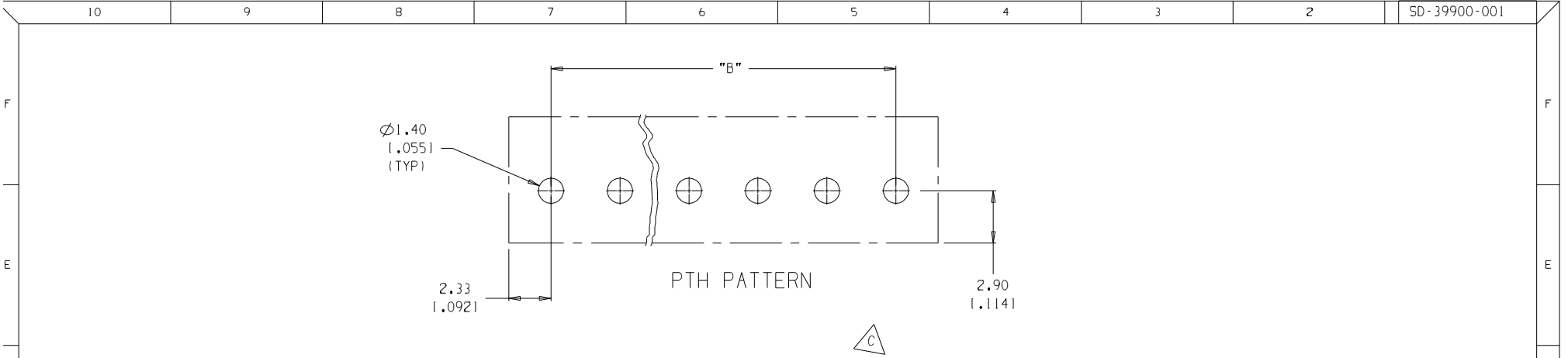

F
E
D
C
B
A

F
E
D
C
B
A

10 9 8 7 6 5 4 3 2 1

NUMBER OF CIRCUITS "XX"	DIM. "A"	DIM. "B"	MATERIAL NO. (G30, BLACK)	MATERIAL NO. (GREEN)	MATERIAL NO. (10AV, BLACK)	MATERIAL NO. (BLACK)
02	8.5 [1.33]	3.81 [1.150]	39901-0502	39900-3502		39900-0502
03	12.3 [1.48]	7.62 [1.300]	39901-0503	39900-3503	39902-0503	39900-0503
04	16.1 [1.63]	11.43 [1.450]	39901-0504	39900-3504		39900-0504
05	19.9 [1.78]	15.24 [1.600]	39901-0505	39900-3505		39900-0505
06	23.7 [1.93]	19.05 [1.750]	39901-0506	39900-3506		39900-0506
07	27.5 [1.08]	22.86 [1.900]	39901-0507	39900-3507		39900-0507
08	31.3 [1.23]	26.67 [1.050]	39901-0508	39900-3508		39900-0508
09	35.1 [1.38]	30.48 [1.200]	39901-0509	39900-3509		39900-0509
10	39.0 [1.53]	34.29 [1.350]	39901-0510	39900-3510		39900-0510
11	42.8 [1.68]	38.10 [1.500]	39901-0511	39900-3511		39900-0511
12	46.6 [1.83]	41.91 [1.650]	39901-0512	39900-3512		39900-0512
13	50.4 [1.98]	45.72 [1.800]	39901-0513	39900-3513		39900-0513
14	54.2 [2.13]	49.53 [1.950]	39901-0514	39900-3514		39900-0514
15	58.0 [2.28]	53.34 [2.100]	39901-0515	39900-3515		39900-0515
16	61.8 [2.43]	57.15 [2.250]	39901-0516	39900-3516	39902-0516	39900-0516
17	65.6 [2.58]	60.96 [2.400]	39901-0517	39900-3517		39900-0517
18	69.4 [2.73]	64.77 [2.550]	39901-0518	39900-3518		39900-0518
19	73.2 [2.88]	68.58 [2.700]	39901-0519	39900-3519		39900-0519
20	77.1 [3.03]	72.39 [2.850]	39901-0520	39900-3520		39900-0520
21	80.9 [3.18]	76.20 [3.000]	39901-0521	39900-3521		39900-0521

EC NO. SEE SHEET 1 DRAWN: CH'K: APPR:	QUALITY SYMBOLS MAJOR CRITICAL SPC	GENERAL TOLERANCES: (UNLESS SPECIFIED)	SCALE 3:1	DESIGN UNITS <input type="checkbox"/> mm <input checked="" type="checkbox"/> INCH	THIRD ANGLE PROJECTION	PROJECT NO. -	-	-
			4 PLACES ±.0015	3 PLACES ±.038 ±.005	2 PLACES ±.13 ±.01	1 PLACE ±.3	ANGULAR: ±2°	DRAFT WHERE APPLICABLE MUST REMAIN WITHIN DIMENSIONS
DESCRIPTION REV			DRAWN BY & DATE W. HOWARD 10-9-03	CHECKED BY & DATE L.ROTHAUS 10-9-03	APPROVED BY & DATE L.ROTHAUS 10-9-03	TITLE: HEADER, VERTICAL 3.81 [1.150]		
			CAD FILENAME 9016XX	MATERIAL NO. SEE TABLE	DRAWING NO. SD-39900-001	SHEET NO. 2 OF 2		

F
E
D
C
B
A