

P		F		ZONE		LTR		REVISIONS		DATE	APPD
								T	ADDED -9 PER NPR 4680 AND REDRAWN ON CAD	04/07/93	-
								T1	REVISED PER ECO-09-020935	08SEP09	KK AEG

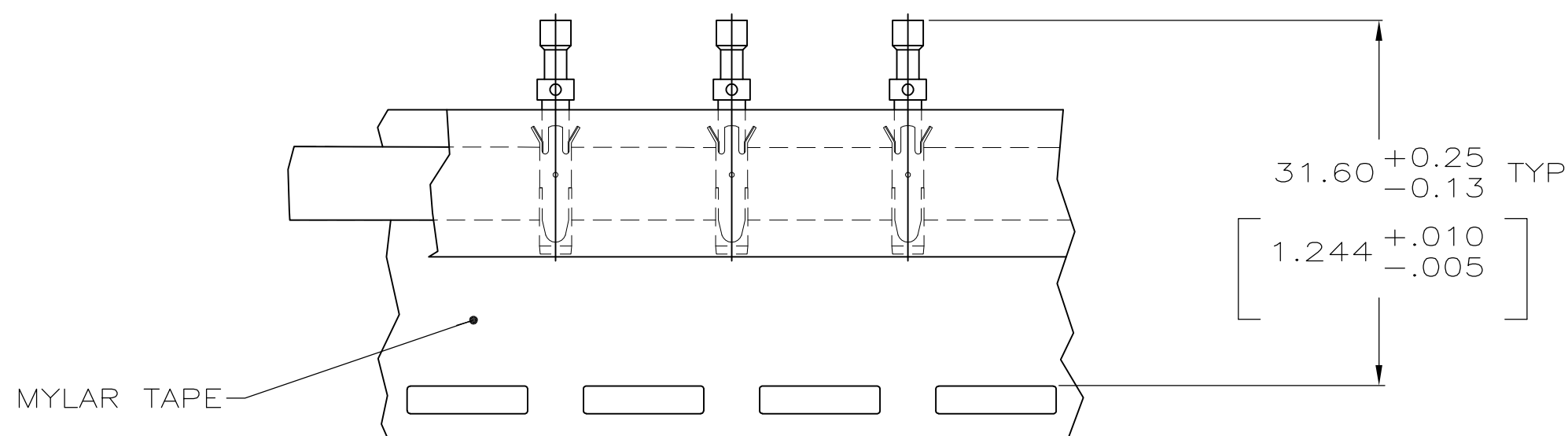
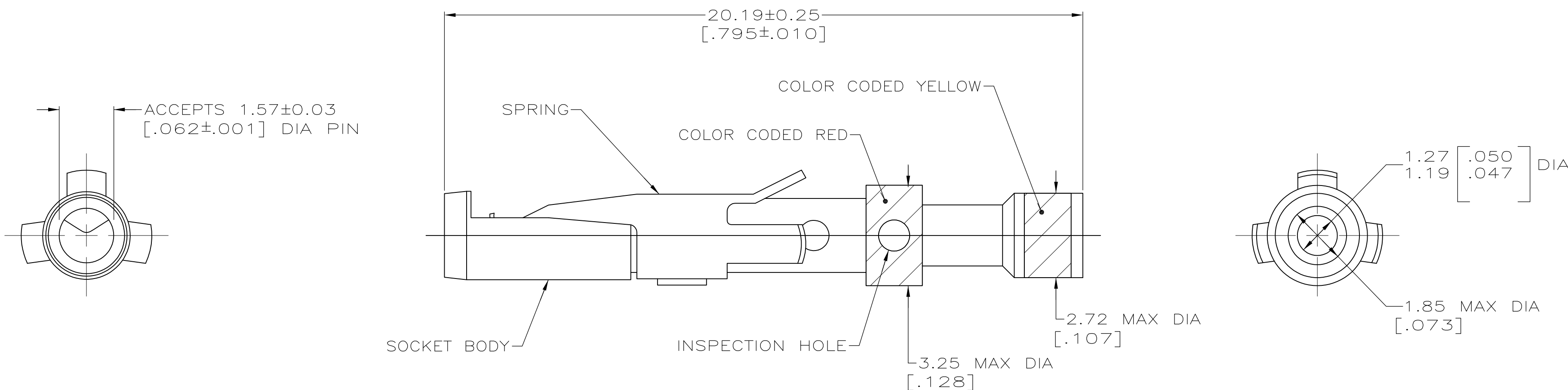

TAPE MTG DETAIL  
SCALE 2:1

- ① 0.76µm [.000030] MIN GOLD OVER 1.27µm [.000050] MIN NICKEL.
- ② 2.54µm [.000100] MIN GOLD OVER 1.27µm [.000050] MIN NICKEL.
- ③ WHEN ORDERING CONTACT ASSEMBLY ON TAPE, ORDER BY THE TAPE NUMBER PLUS THE PACKAGING CODE AS FOLLOWS:
  1. FOR USE WITH AMP TAPETRONIC, PNEUMATIC TOOL—
    - A. 1000 PARTS TO A BOX ADD PACKAGING CODE: 1MBOX
  2. FOR USE WITH 4/8 INDENT STRIPPER CRIMPER—
    - A. 1000 PARTS TO A REEL ADD PACKAGING CODE: 1MREEL
    - B. 5000 PARTS TO A REEL ADD PACKAGING CODE: 5MREEL
- ④ OBSOLETE PARTS: OBSOLETE CIS STREAMLINING PER D.RENAUD/D.SINISI

④ OBSOLETE	SMALL PACK	①	-201580-9-
	TAPE MTG (SEE DETAIL) ③	②	-201580-7-
	TAPE MTG (SEE DETAIL) ③	①	-201580-4-
	STANDARD	②	201580-3
	STANDARD	①	201580-1

PACKAGING TYPE		SOCKET BODY FINISH	PART NO
DO NOT SCALE PRINT. UNLESS SPECIFIED DIMENSIONS IN mm [INCHES] TOLERANCES ON :	DR 04/07/93 D.GELTZ	<b>AMP</b> AMP Incorporated Harrisburg, PA 17105-3608	CONTACT ASSEMBLY, SOCKET, #16, 20-24 AWG, TYPE II
2 PLC DEC ± -	CHK 4-26-93 R.STONE		
3 PLC DEC ± -	APPD 4-29-93 R.S.KLINE	NAME	
ANGLES ± -	APPD -	SIZE	
MATERIAL	PRODUCT SPEC	CAGE CODE	DRAWING NO
SOCKET BODY: COPPER ALLOY	-	③ 00779	③-201580
SPRING: STAINLESS STEEL	APPLICATION SPEC	SCALE	SHEET
FINISH	-	10:1	1 OF 1
SOCKET BODY: SEE TABLE	WEIGHT	-	-

THIS DRAWING IS A CONTROLLED DOCUMENT FOR AMP INCORPORATED. IT IS SUBJECT TO CHANGE AND THE CONTROLLING ENGINEERING ORGANIZATION SHOULD BE CONTACTED FOR THE LATEST REVISION.