

IRCS2277S Demo Board

For 3-phase / 380V motor drives

IRCS2277S Demo Board

- Up to 1200V DC-bus capability
- IR2277S device connected for 3-phase current sensing
- Open drain PWM output (PO)
- Open drain Over Current output (OC)
- Ratiometric analog output for A/D converters compatibility
- On-board disconnectable 5V reference
- On-board bootstrap supply for high-side gate drive
- Same board can host IR2177S or IR22771S or IR21771S, in place of IR2277S

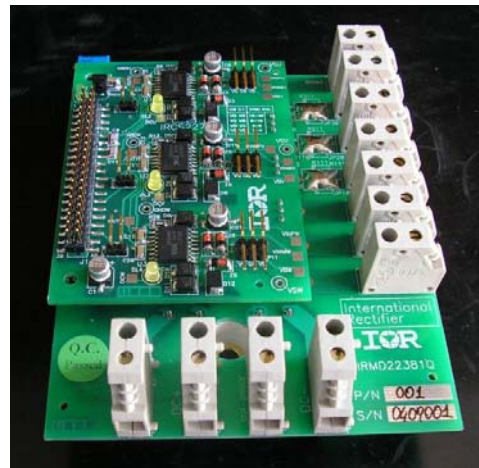

IRCS2277S Demo Board
 (Shown above not including IRMD22381Q demo board)

Stacked boards compatibility

- Connectable on top of IRMD2214SS and IRMD22141SS demo boards
- Connectable on top of IRMD22381Q demo board

Introduction

The IRCS2277S demo board is an evaluation board for IR2277S current sensor (see device data sheet for details). IRCS2277S is designed to read 3-phase motor currents on top of pin-out compatible gate driver boards. The board can be used for both AC and Brushless motors current sensing by reading the voltage developed on shunt resistors. The board is a flexible solution for different applications and can be customized by means reconfigurable components options. Three-phase shunt resistor (with sensing pins) must be placed in the gate driver board. Both PWM and ratiometric analog outputs are provided for all of the three phases. Both PWM output and Over Current signal are provided as open collector outputs. Board layout has been studied to reduce noise coupling between high and low voltage signals.

Application Block Diagram

(Refer to connections section to see interface pins) This diagram shows the main blocks and connections of the demo board and the external components necessary in a typical motor drive application.

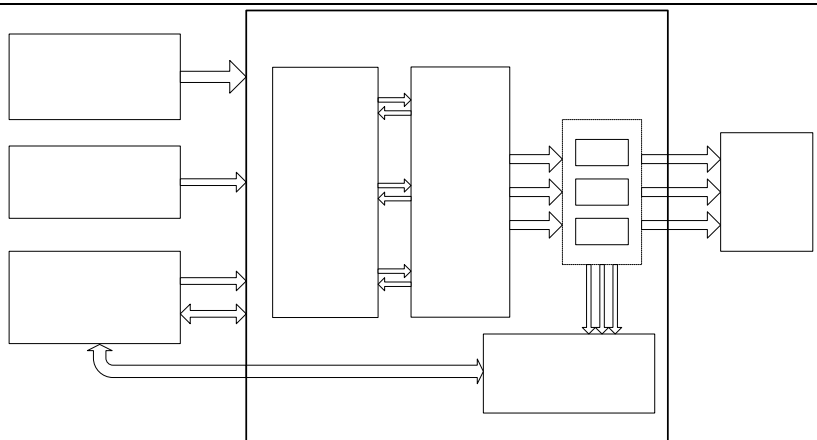

Table of contents

INTRODUCTION 1
Table of contents..... 2
Table of figures 2
The IR2277S..... 3
The stacked structure of HVIC demo boards..... 3
Important Notice..... 3
BOARD CONNECTORS 4
Connection with the system controller 4
V_{RL}, V_{RH}, OUT_U, OUT_V, OUT_W..... 5
V_{CC} supply pin 5
V_{SS} ground pin (GND) 5
Connecting the current sensors 6
Test Points 6
TEST BENCH CONNECTION 7
OPERATING DESCRIPTION 8
Normal operating mode 8
Precharge of the bootstrapped sections 8
BOARD CUSTOMIZATION 8
Bootstrap circuit 8
G0 and G1 selection 9
OTHER EXTRA COMPONENTS 9
Clamping Diode for V_s below ground 9
RC filter on V_{INP} and V_{INM} 10
Analog output OUT 11
Auto-reset function 11
BILL OF MATERIAL 12
LAYOUT 14

Table of figures

Figure 1: BOTTOM and TOP image with connectors..... 4
Figure 2: LED connection 5
Figure 3: Test bench connection 7
Figure 4: Bootstrap circuit..... 8
Figure 5: undershoot clamp 9
Figure 6: Vin filter 10

Parameters	Values	Description, condition
Input Power		
V _{CC}	15V typ	Low voltage power supply. Follow IR2277S data sheet for supply setting
V _{SS}	ground	Low voltage ground
I _{CC}	25 mA (max)	quiescent V _{CC} current
Control Inputs/Outputs		
40 pin connector J1 I/Os	3.3V to 15V compatible	see "Board Connectors" section on page 4

The IR2277S

The IR2277S is a high voltage current sensor, best suited for AC motor drive applications. An integrated adaptive filter provides superior ripple rejection on phase current measurement being synchronous with PWM carrier (SYNC input). A ratiometric analog output is provided by each device to the controller in a range that can be set through V_{RH} and V_{RL} pins. PWM open collector outputs are also provided for those controllers which do not use A/D converters for current measurement. Over current detection is also available via open collector OC pins.

For further technical information see the IR2277S data sheet at <http://www.irf.com>.

The stacked structure of HVIC demo boards

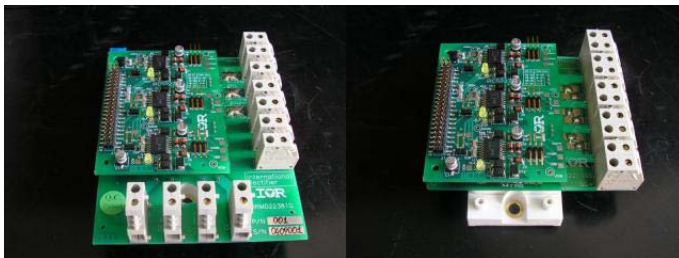

IRCS2277S demo board is fully compatible with standard pin out of IRMD2214xSS and IRMD22381Q demo boards.

The HVIC demo boards are structured to work together on top of an ECONO2 power module or a PowerPCB.

Important Notice

IRCS2277S demo board is supplied with a tentative Bill of Material suitable for a generic 380V generic 3-phase motor drive application. The BOM presented on page 12 provides just a suggestion.

It is strongly recommended to customize the demo board to fit the application requirements for the power level that has been chosen.

Board Connectors

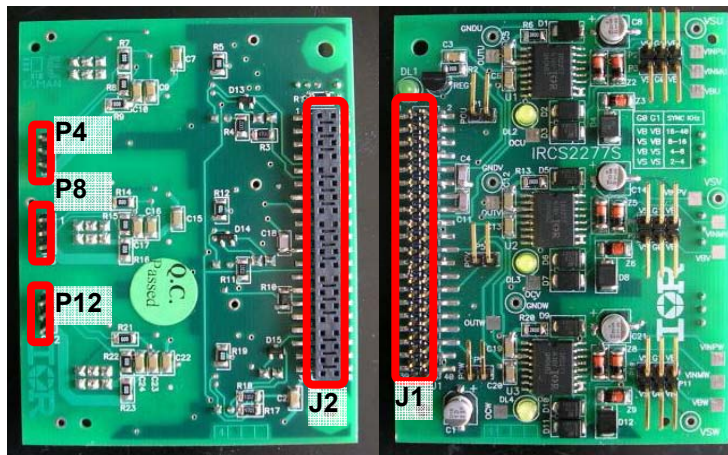

Figure 1: BOTTOM and TOP image with connectors

Connection with the system controller

On board there is a 40 pins connector for the control signals. The current sense board uses 26 pins. The remaining pins are for the sensing board (IRCS2277S) that can be connected on top of IRMD22381Q board.

Table 1: 40-pin connector J2 and J1

		1 ○ ○ 2				1 ○ ○ 2	
		3 ○ ○ 4				3 ○ ○ 4	
		5 ○ ○ 6	8	OUT _U		5 ○ ○ 6	
		7 ○ ○ 8	10	OC _U	7	7 ○ ○ 8	
		9 ○ ○ 10	12	PO _U	9	9 ○ ○ 10	
		11 ○ ○ 12			11	11 ○ ○ 12	14
V _{RL}	13	13 ○ ○ 14	16	V _{RH}	15	13 ○ ○ 14	16
OUT _V	15	15 ○ ○ 16	18	V _{SS}	17	15 ○ ○ 16	18
V _{SS}	17	17 ○ ○ 18	20	V _{SS}	19	17 ○ ○ 18	20
V _{SS}	19	19 ○ ○ 20				19 ○ ○ 20	22
OUT _W	21	21 ○ ○ 22				21 ○ ○ 22	OUT _W
		23 ○ ○ 24	24	SYNC	23	23 ○ ○ 24	
		25 ○ ○ 26				25 ○ ○ 26	
PO _V	27	27 ○ ○ 28	28	OC _V	27	27 ○ ○ 28	28
		29 ○ ○ 30				29 ○ ○ 30	PO _V
		31 ○ ○ 32				31 ○ ○ 32	
		33 ○ ○ 34				33 ○ ○ 34	
PO _W	35	35 ○ ○ 36	36	OC _W	35	35 ○ ○ 36	36
V _{CC}	37	37 ○ ○ 38	38	V _{CC}	37	37 ○ ○ 38	38
V _{CC}	39	39 ○ ○ 40	40	V _{CC}	39	39 ○ ○ 40	40

Logical signals SYNC, PO_U, PO_V, PO_W, OC_U, OC_V, OC_W

SYNC and PO_x logic inputs are 5V and 3.3 V compatible CMOS I/O ports. SYNC input must be a 50% duty-cycle square wave that provides filter synchronization with PWM carrier. PO_x as an input is used for over current reset when auto-reset function is disabled. As an opened drain output, PO_x is pull-up with a resistor to 15V supply. OC_x open drain output is also pulled-up to 15V supply. Both pull-up resistors can be removed in order to use a different supply provided in the controller board. OC_x pins are connected to a yellow led (see Figure 2) indicating the overcurrent condition of the respective current sensor. This led will be disabled when connecting OC_x to a different pull-up.

V_{RL}, V_{RH}, OUT_U, OUT_V, OUT_W

V_{RL} and V_{RH} inputs are the reference voltages for the OUTx analog output of the current sensors.

V_{RL} is the low voltage rail for OUTx and it is connected to V_{SS} by a 0 Ohm resistor. V_{RH} is the high voltage rail for OUTx and it is connected to a linear 5V regulator by a 0 Ohm resistor.

Both V_{RH} and V_{RL} can be disconnected to the respective supplies (V_{SS} and 5V regulator) in order to be supplied by the controller board.

OUTx are directly connected to the IR2277S devices output.

Note: further information about IR2277S I/Os are described in details in IR2277S data sheet.

V_{CC} supply pin

This is the supply pin for all the devices. On board a green LED indicates the supply power on; Figure 2b shows the connection.

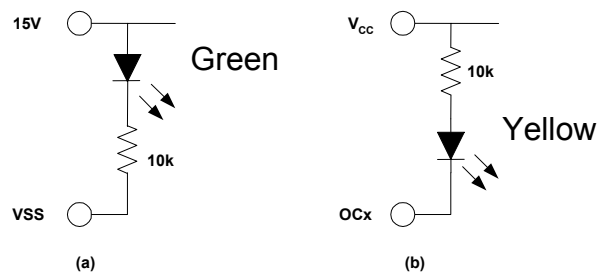

Figure 2: LED connection

V_{SS} ground pin (GND)

When stacked together, the board ground is shared among the stack. Gate drivers board share the V_{SS} with DC- (power ground) with a star connection on DC-.

Connecting the current sensors

P1, P2 and P3 are connected with the optional shunt resistors placed on the driver board between the phase output nodes and the motor.



CONNECTOR P4		
SHU+ (motor side)	1	
SHU- (power module side)	2	
U	3	
CONNECTOR P8		
SHV+ (motor side)	1	
SHV- (power module side)	2	
V	3	
CONNECTOR P12		
SHW+ (motor side)	1	
SHW- (power module side)	2	
W	3	

Table 2: P4, P8 and P12 connectors for Kelvin contacts to shunt signals

SHU, SHV and SHW are sense pins connected to the shunt resistors terminals.

Test Points

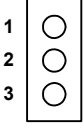
Test points on board provide signals that are not available at the connectors. See the following table:

ONE FOR EACH CHANNEL (CH1 → U, CH2 → V, CH3 → W)	
$V_{Bu,v,w}$	High side floating supply voltage
$V_{Su,v,w}$	High side floating supply offset voltage (jumper)
$VINP_{u,v,w}$	Current sensor positive input
$VINM_{u,v,w}$	Current sensor negative input
$OUT_{u,v,w}$	Analog output
$PO_{u,v,w}$	PWM output
$OC_{u,v,w}$	Overcurrent output
$GND_{u,v,w}$	Local ground (V_{SS})

Table 3: Test points

Test Bench connection

IRMD2277S does NOT provide opto isolation.

The following picture shows the recommended connections for board evaluation. Bold lines are equipotential (DC-=Vss=gnd).

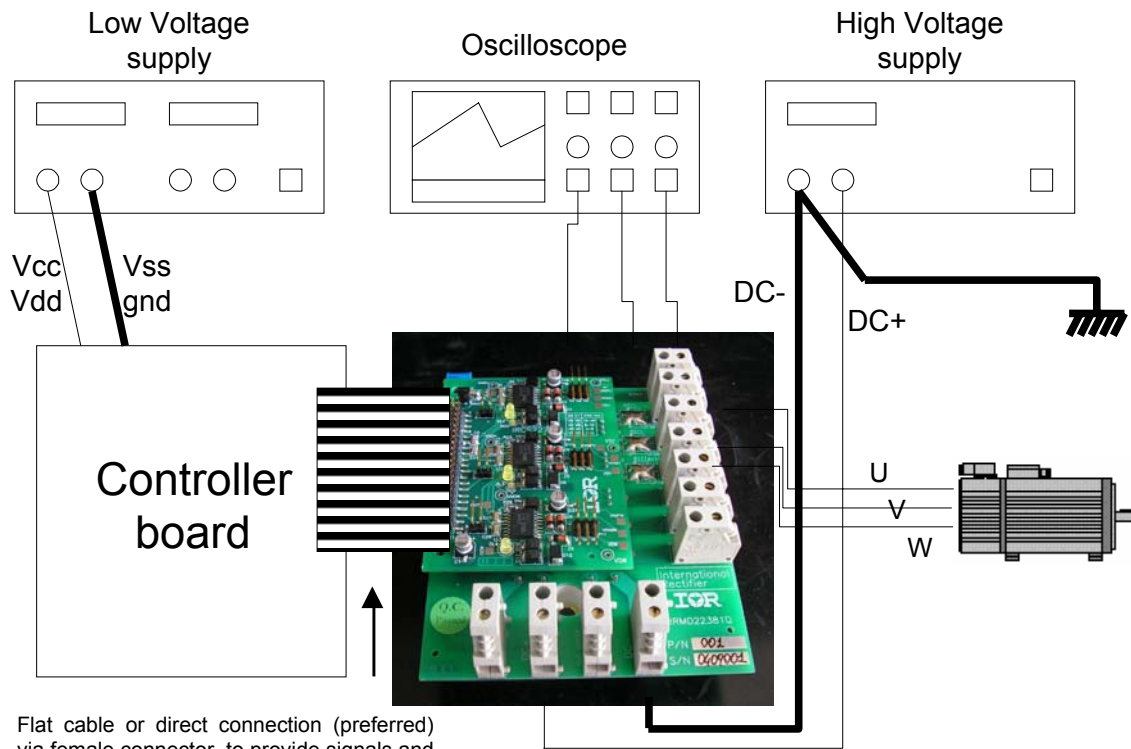

Flat cable or direct connection (preferred) via female connector, to provide signals and supply ($V_{cc}=15V$ typ)

Figure 3: Test bench connection

OPERATING DESCRIPTION

Normal operating mode

The IRCS2277S demo board has to be connected to a board equipped with shunt resistors to be operated properly.

IRMD22381Q, IRMD2214SS and IRMD22141SS driver boards can be connected with the IRCS2277S current sensing board through the 40-pin connector J2 and the 3-pin connectors P4, P8 and P12. J1 reflects J2 connector bringing all the signals to the controller board.

More information is available with gate driver board data sheets.

Pre-charge of the bootstrapped sections

High voltage current sensor sections are supplied by bootstrap topology technique.

It's recommended to pre-charge the bootstrap supplies before starting to drive the motor with the preferred driving scheme.

BOARD Customization

This demo board is meant to be flexible for self-customization. Place for many spare components allow to verify functionality of the current sensors under different external configurations.

This section will go through the possible customizations of the board.

Bootstrap circuit

The high side floating supply (V_{BS}) is provided by a bootstrap capacitor. Figure 4 shows the circuit on board.

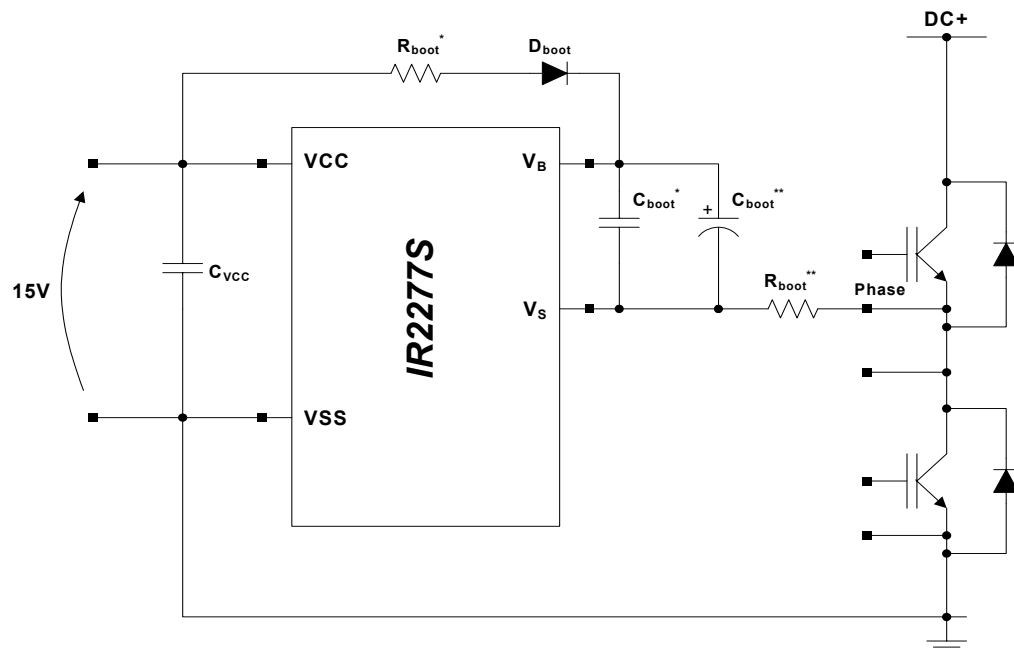

Figure 4: Bootstrap circuit

The following table shows the names of these components on board.

	U	V	W
C_{VCC}	C5	C12	C19
C_{boot}^*	C7	C15	C22
C_{boot}^{**}	C8	C14	C21
R_{boot}^*	R6	R13	R20
R_{boot}^{**}	R9	R16	R23

G0 and G1 selection

G0 and G1 gain selectors of each IR2277S device can be set by using P2, P3, P6, P7 and P10, P11 jumpers.

Other extra components

These components are provided to make IRMD2277S board as customizable as possible. In many cases the use of the extra components is not necessary.

Clamping Diode for V_S below ground

This solution preserves the device when the V_S , V_{inp} and V_{inm} pins go below ground out of the device absolute maximum ratings. The pins voltage is clamped to the maximum value allowed by a zener diode.

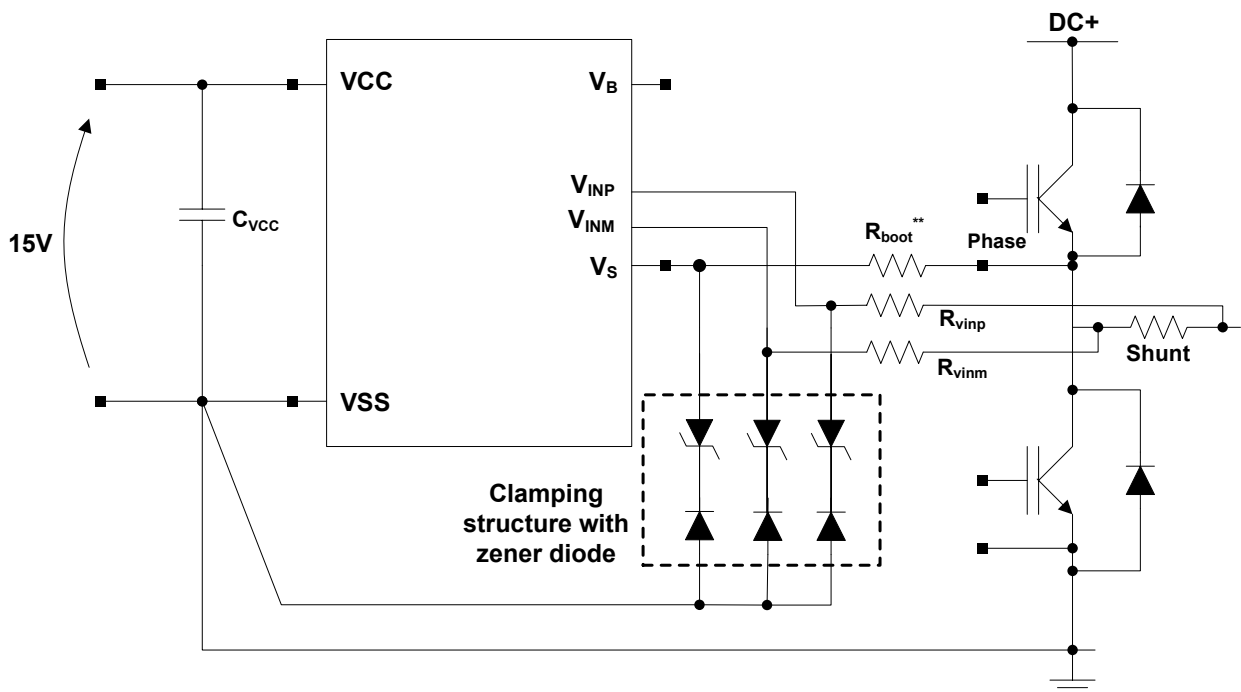

Figure 5: undershoot clamp

The following table shows the names of these components on board.

	U	V	W
V _S DIODE	D4	D8	D12
V _S ZENER	Z3	Z6	Z9
V _{INM} DIODE	D3	D7	D11
V _{INM} ZENER	Z2	Z5	Z8
V _{INP} DIODE	D2	D6	D10
V _{INP} ZENER	Z1	Z4	Z7
R _{VINP}	R7	R14	R21
R _{VINM}	R8	R15	R22

NOTE: It must be noticed that during bootstrap filling, voltage will be developed across R_{boot}^{**}. It is important in that case to evaluate the voltage difference between V_S and V_{INP}/V_{INM}, that must stay in the maximum operating condition specified by the data sheet of the IR2277S. Filter capacitors (see next par.) across V_{INP}/V_{INM} and V_S may help in staying in the specified voltage range,

RC filter on V_{INP} and V_{INM}

High frequency filter capacitors are located at V_{INP} and V_{INM} pins. They can be placed either in common mode (across pins and V_S) or in differential mode (between V_{INP} and V_{INM}).

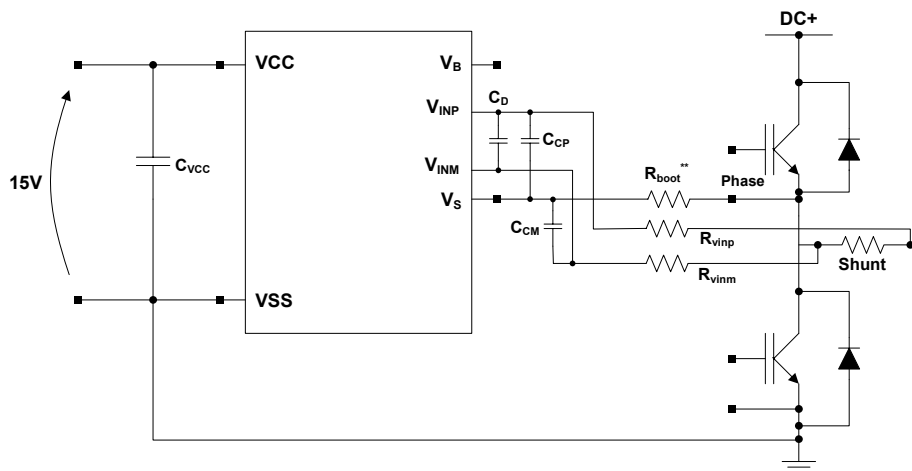

Figure 6: V_{IN} filter

The following table shows the names of these components on board.

	U	V	W
C _{CP}	C9	C16	C23
C _{CM}	C10	C17	C24
R _D	Use C9 and C10 pads	Use C16 and C17 pads	Use C23 and C24 pads

Analog output OUT

Analog outputs OUT_U , OUT_V and OUT_W are provided to the 40-pin connector with a capacitor that is connected to V_{RL} as per the following table.

	U	V	W
C_{FILTER}	C4	C11	C18

V_{RL} is shorted to local V_{SS} by 0 Ohm resistors as follows:

	U	V	W
R_{VRL}	R5	R12	R19

To use a different voltage to supply the analog output low rail, disconnect these resistors.

V_{RH} is shorted to a linear 5V regulator (7805) output. Remove the 0 Ohm resistor R2 to disconnect the voltage regulator and provide the analog output high voltage rail via 40-pin connector.

The following table shows the names of these components on board.

Auto-reset function

To reset automatically IR2277 current sensors when they latch an overcurrent condition, short pin 1 to pin 2 of jumpers P1 (U1), P5 (U2) and P9 (U3).

Bill of material

Numeration	Description	Value	Units	Numeration	Description	Value	Units
DL1	Supply Led	Green		Phase V - HS			
R1	Supply Led bias resistor	10K	Ohm	R14	Vin+ filter and protection resistor	10	Ohm
R2	On-board 5V regulator series resistor	0	Ohm	R15	Vin- filter and protection resistor	10	Ohm
R3	On-board 5V regulator cap	100n	F	R16	Vs filter and protection resistor	0	Ohm
REG1	On-board 5V regulator	78LD5		D6	negative Vin+ protection	STTA112U	
C1	Supply cap (electrolytic)	10u	F	Z4	negative Vin+ protection	10	V
C2	Supply cap	100n	F	D7	negative Vin- protection	STTA112U	
Phase U - HS				Z5	negative Vin- protection	10	V
R7	Vin+ filter and protection resistor	10	Ohm	D8	negative Vs protection	STTA112U	
R8	Vin- filter and protection resistor	10	Ohm	Z6	negative Vs protection	10	V
R9	Vs filter and protection resistor	0	Ohm	C16	Vin+ filter cap	100n	F
D2	negative Vin+ protection	STTA112U		C17	Vin- filter cap	100n	F
Z1	negative Vin+ protection	10	V	C15	Bootstrap cap	1u	F
D3	negative Vin- protection	STTA112U		C14	Bootstrap cap (electrolytic)	DNM	
Z2	negative Vin- protection	10	V	R13	Bootstrap resistor	33	Ohm
D4	negative Vs protection	STTA112U		D5	Bootstrap diode	STTA112U	
Z3	negative Vs protection	10	V	Phase V - LS			
C9	Vin+ filter cap	100n	F	DL3	Over current Led	Yellow	
C10	Vin- filter cap	100n	F	D14	Auto-reset diode	BAS16	
C7	Bootstrap cap	1u	F	R10	PO pull-up	4K7	Ohm
C8	Bootstrap cap (electolytic)	DNM		R11	OC pull-up	10K	Ohm
R6	Bootstrap resistor	33	Ohm	C12	Vcc cap	100n	F
D1	Bootstrap diode	STTA112U		R12	VRL to Vss short	0	Ohm
Phase U - LS				C13	VRH-VRL cap	100n	F
DL2	Over current Led	Yellow		C11	Analog OUT cap	5n	F
D13	Auto-reset diode	BAS16					
R3	PO pull-up	4K7	Ohm				
R4	OC pull-up	10K	Ohm				
C5	Vcc cap	100n	F				
R5	VRL to Vss short	0	Ohm				
C6	VRH-VRL cap	100n	F				
C4	Analog OUT cap	5n	F				
Phase W - HS							
R21	Vin+ filter and protection resistor	10	Ohm				
R22	Vin- filter and protection resistor	10	Ohm				
R23	Vs filter and protection resistor	0	Ohm				
D10	negative Vin+ protection	STTA112U					
Z7	negative Vin+ protection	10	V				
D11	negative Vin- protection	STTA112U					
Z8	negative Vin- protection	10	V				
D12	negative Vs protection	STTA112U					
Z9	negative Vs protection	10	V				
C23	Vin+ filter cap	100n	F				
C24	Vin- filter cap	100n	F				
C22	Bootstrap cap	1u	F				
C21	Bootstrap cap (electolytic)	DNM					
R20	Bootstrap resistor	33	Ohm				
D9	Bootstrap diode	STTA112U					
Phase W - LS							
DL4	Over current Led	Yellow					
D15	Auto-reset diode	BAS16					
R17	PO pull-up	4K7	Ohm				
R18	OC pull-up	10K	Ohm				
C19	Vcc cap	100n	F				
R19	VRL to Vss short	0	Ohm				
C20	VRH-VRL cap	100n	F				
C18	Analog OUT cap	5n	F				

SCHEMATIC

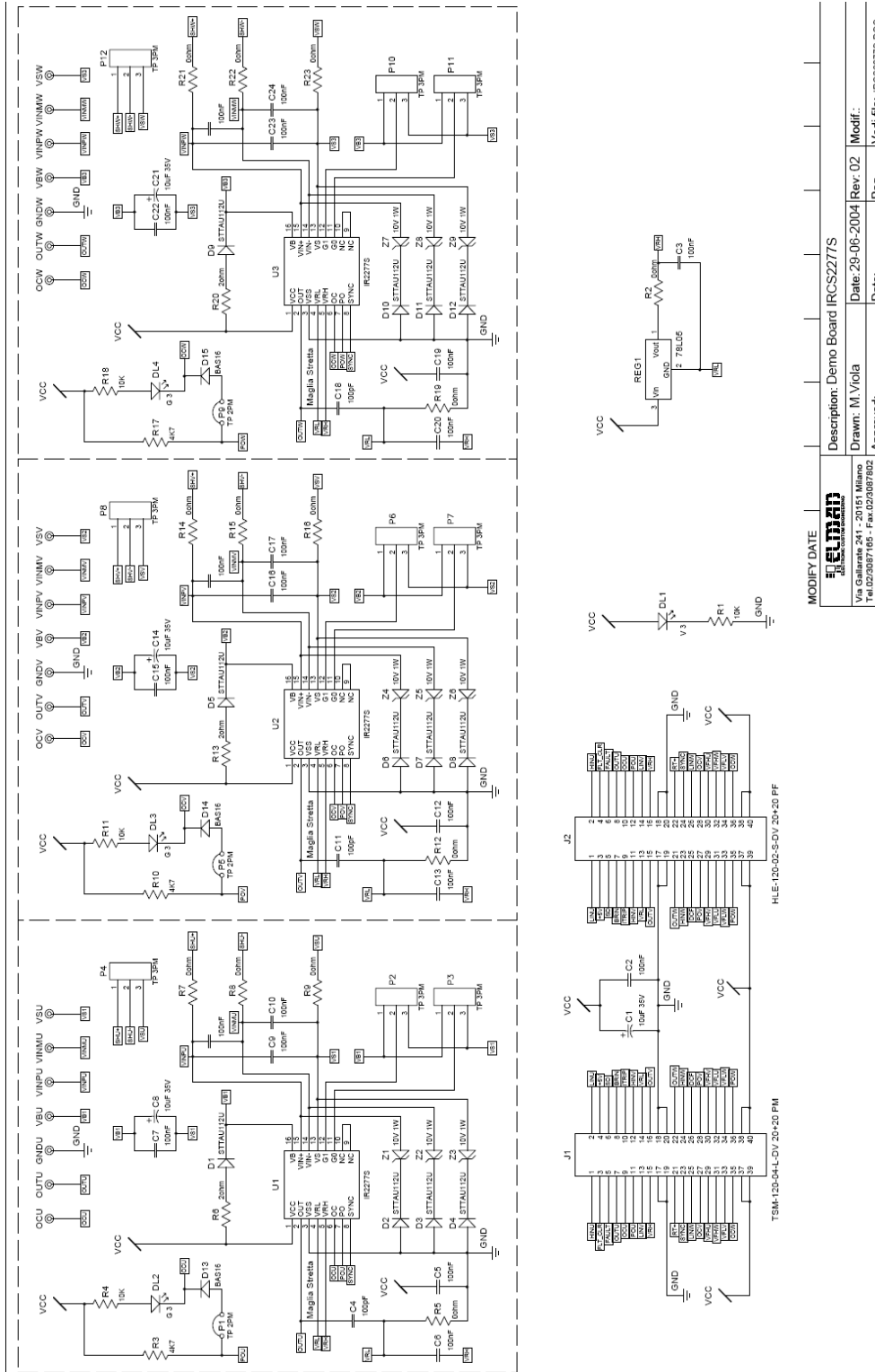

MODIFY DATE		Description: Demo Board IRCS2277S	
2004-06-29	02	Drawn: M.Viola	Rev: 02
Via Gallarate 241 - 20151 Milano Tel.02/2087166 - Fax.02/2087802 E-mail: info@siman-systems.com		Approved:	Vedi file: IRCS2277S.DOC
Date:	Pag.	Date:	Pag.

LAYOUT

TOP LAYER and measures

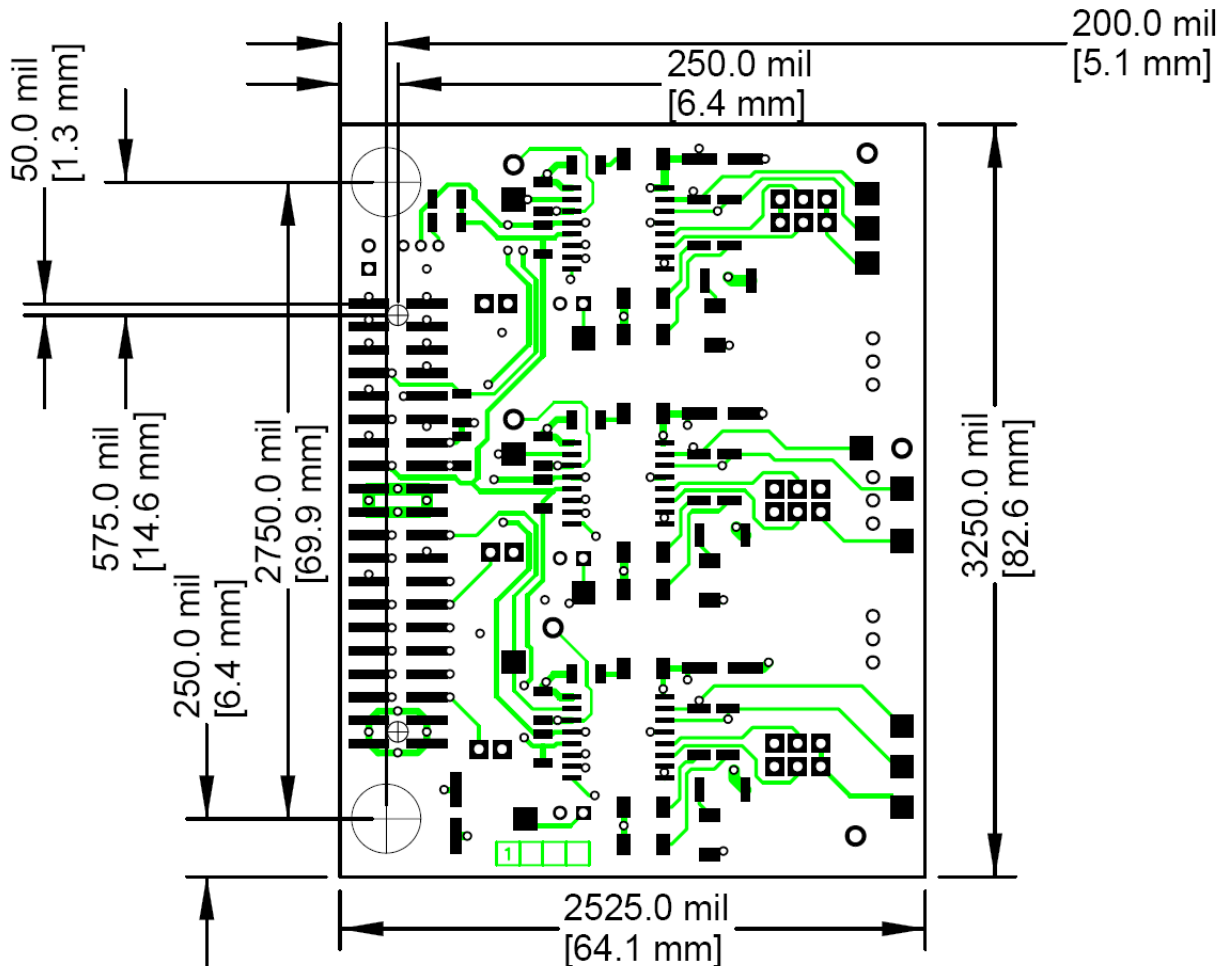

TOP LAYER

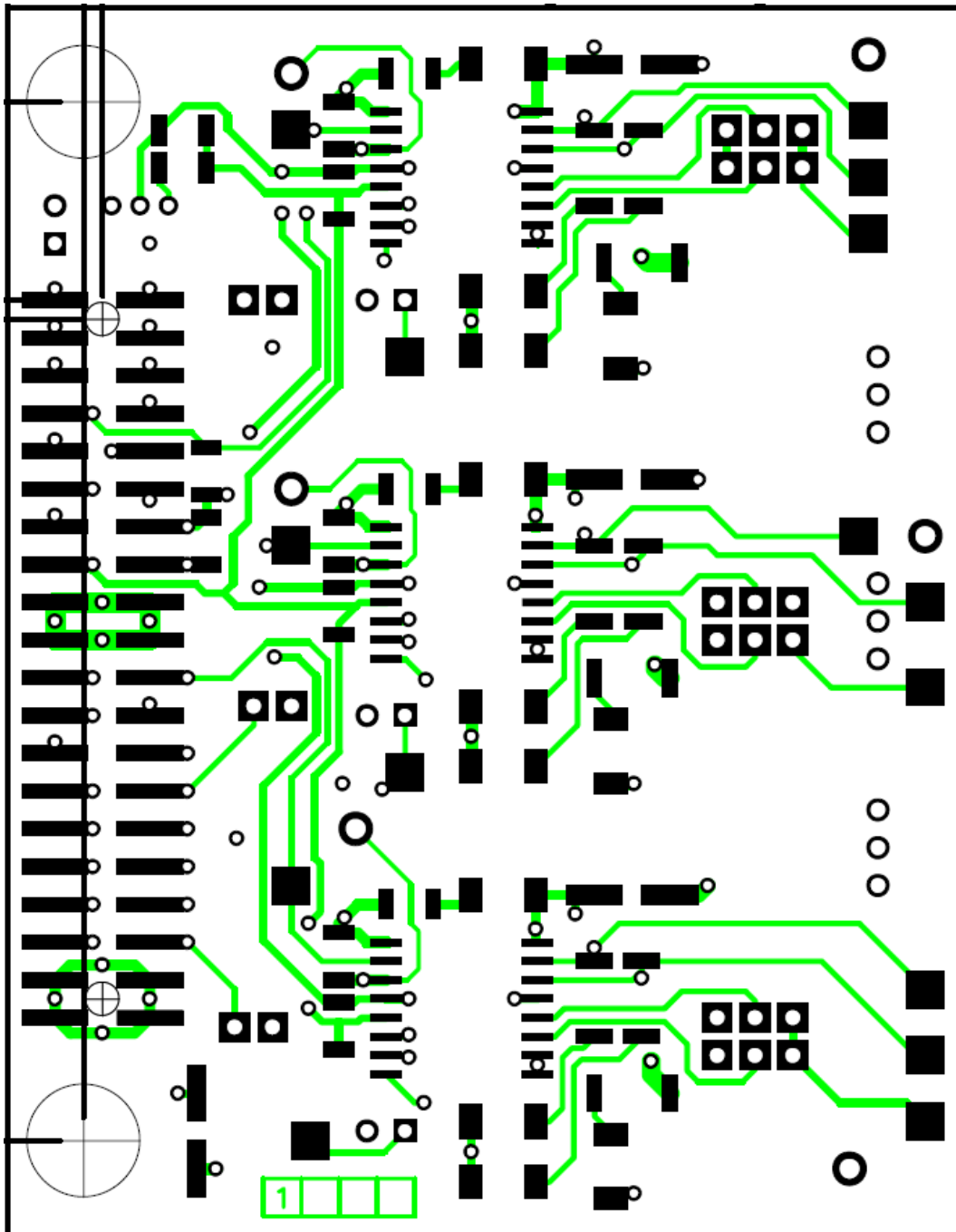

INT1 LAYER

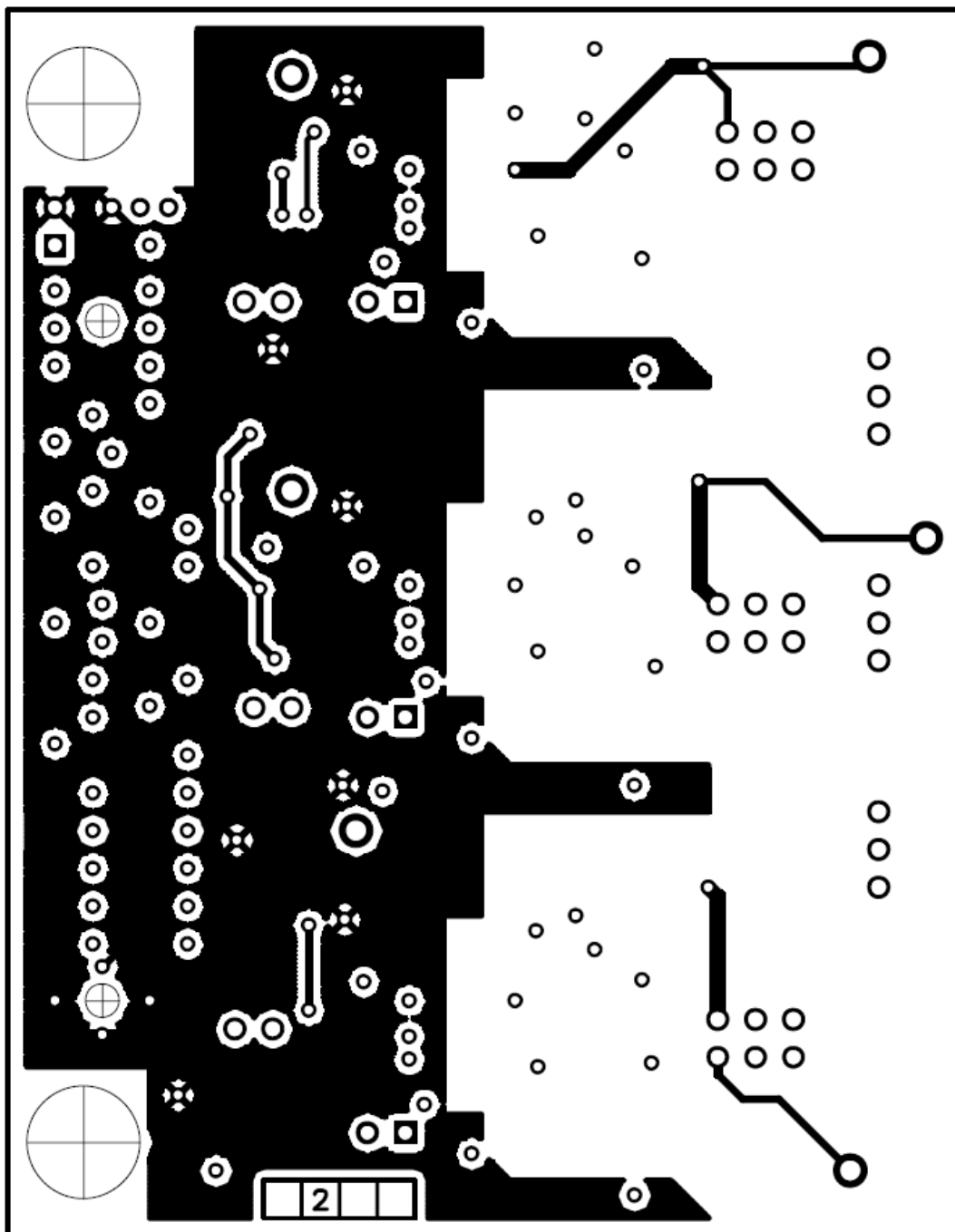

INT2 LAYER

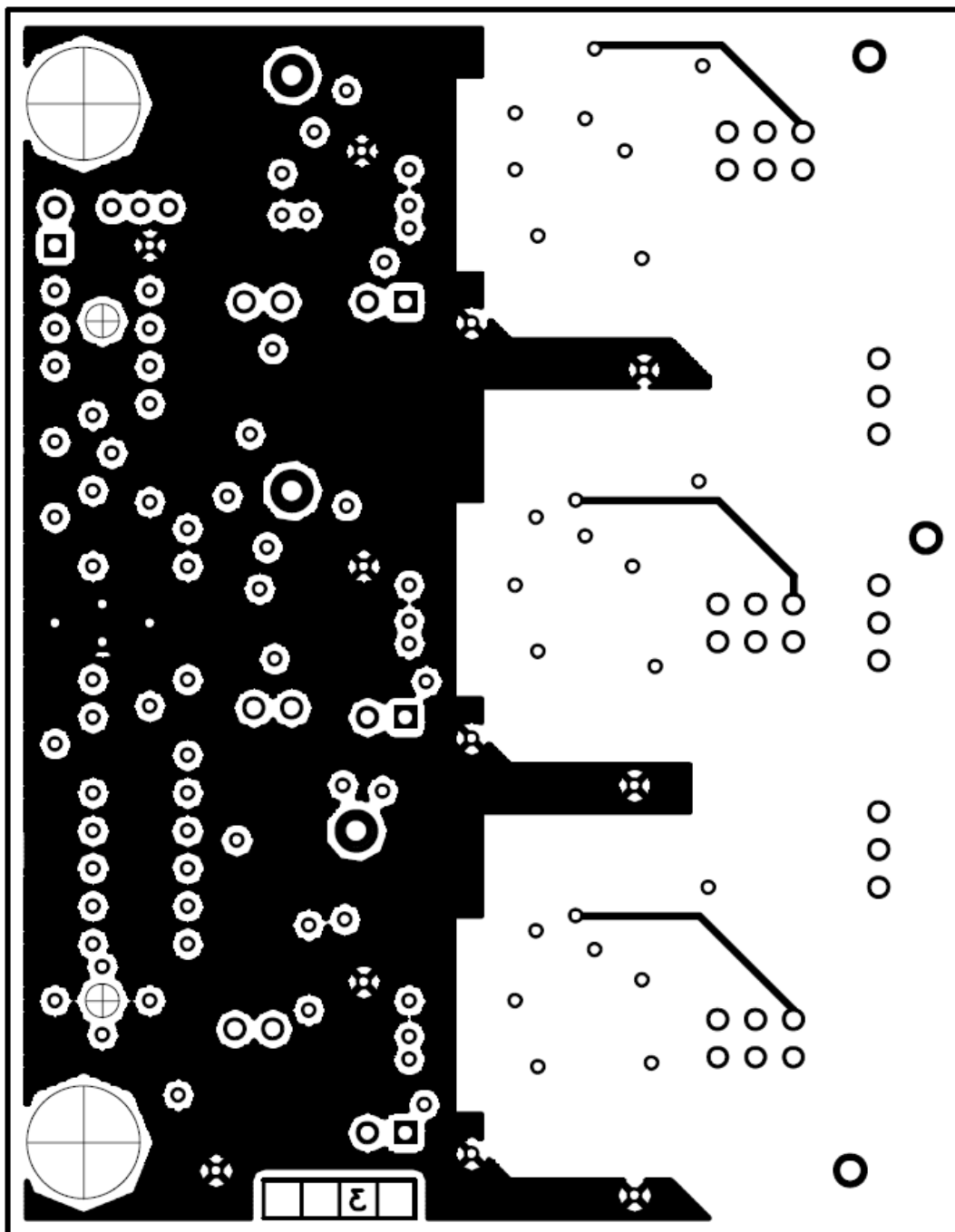

BOT LAYER

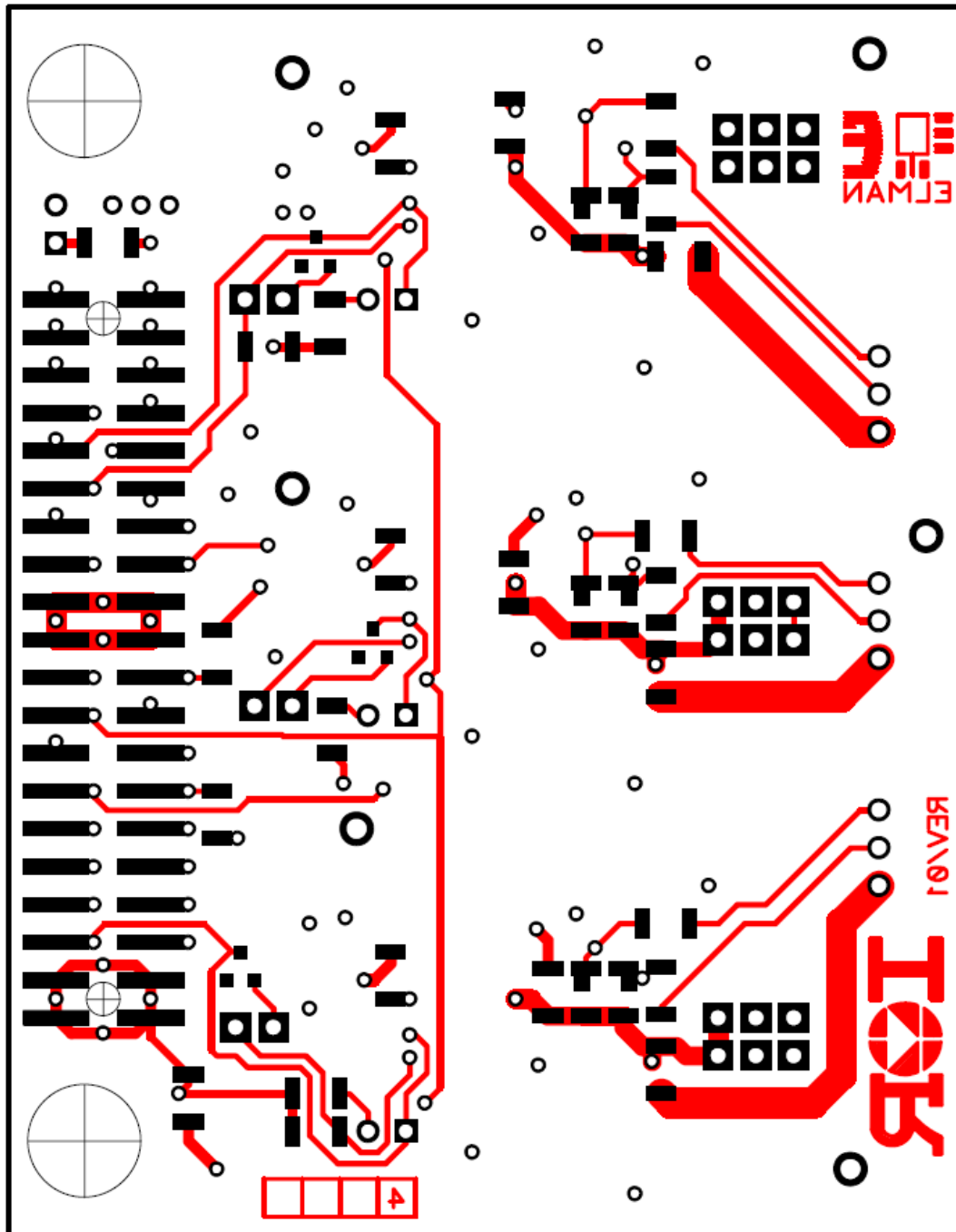

TOP SILK

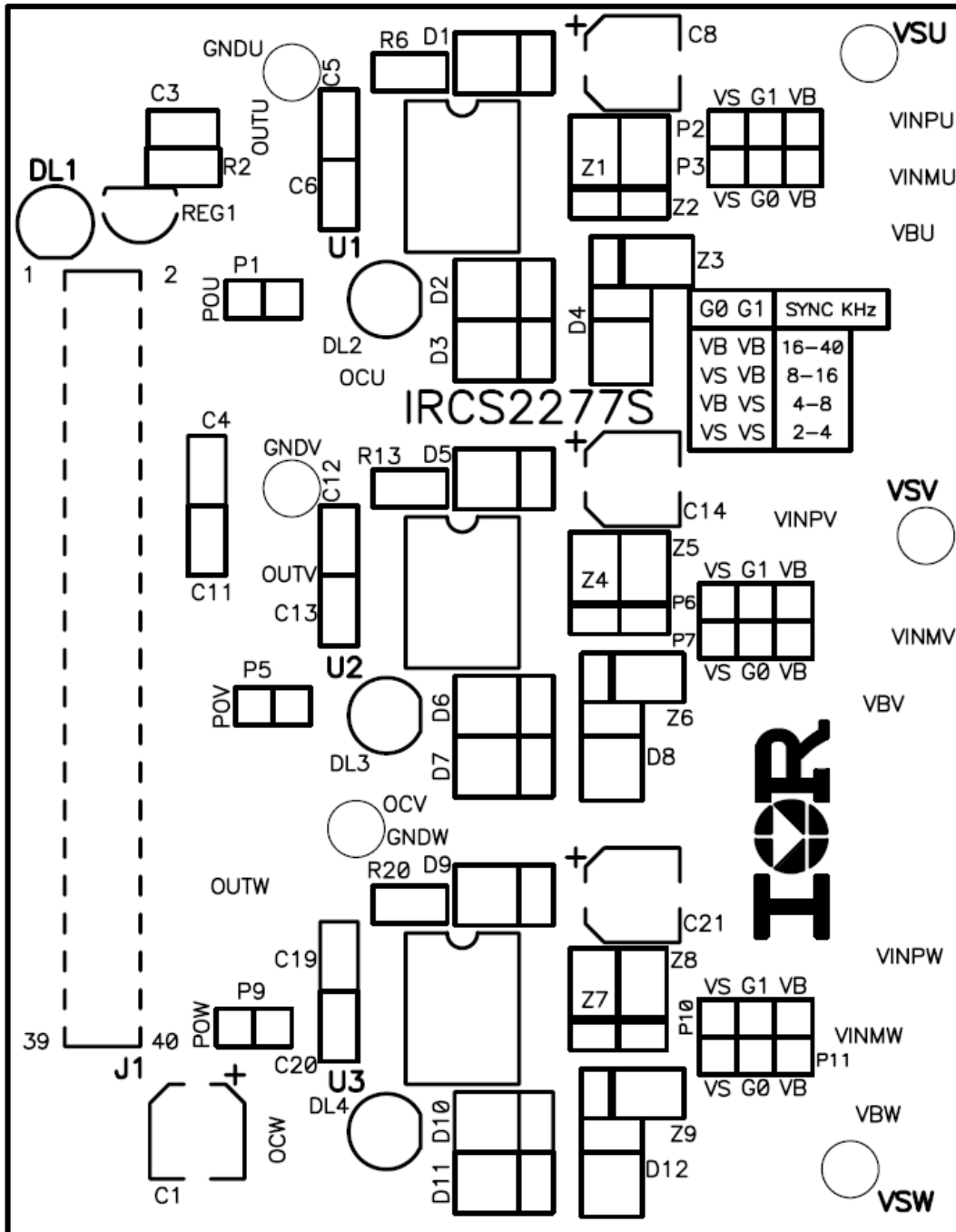

BOT SILK

