

2X Ø.148 [3.76]
 Ø.004 [0.10] A B C

S280W601-116
 RBGP48-116N
 09922 - ZZ YR WK
SOURIAU

CUSTOMER PART NO.,
 SOURIAU CATALOG NO.,
 CAGE NO., DATE CODE,
 AND NAME INK STAMPED.
 COLOR WHITE.

CATALOG NO. RBGP48-116N SHOWN

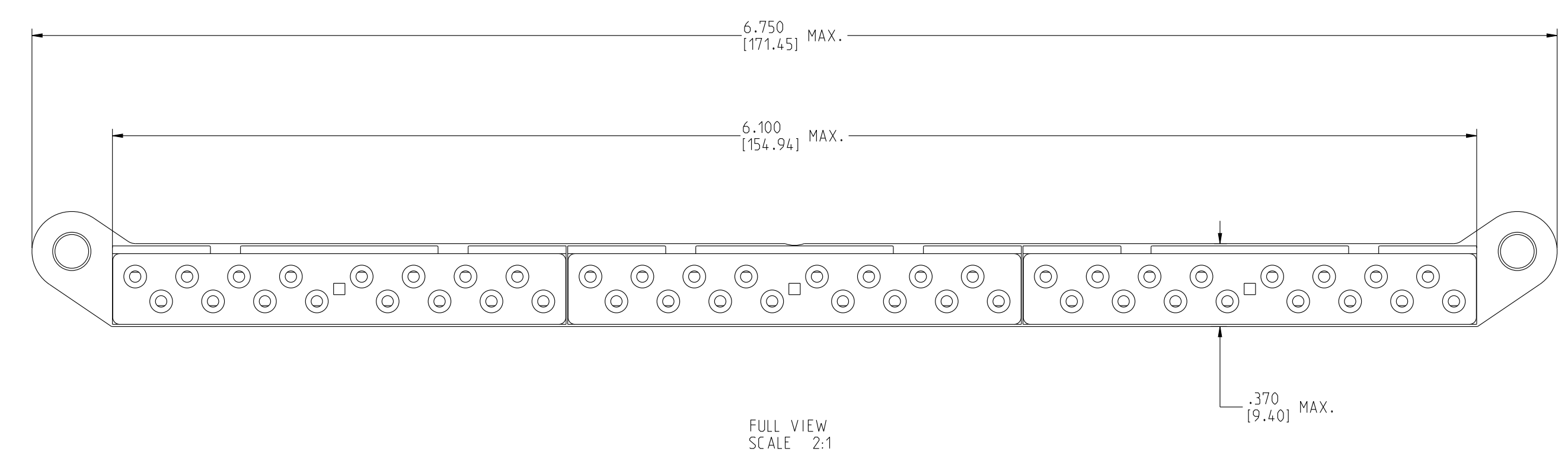
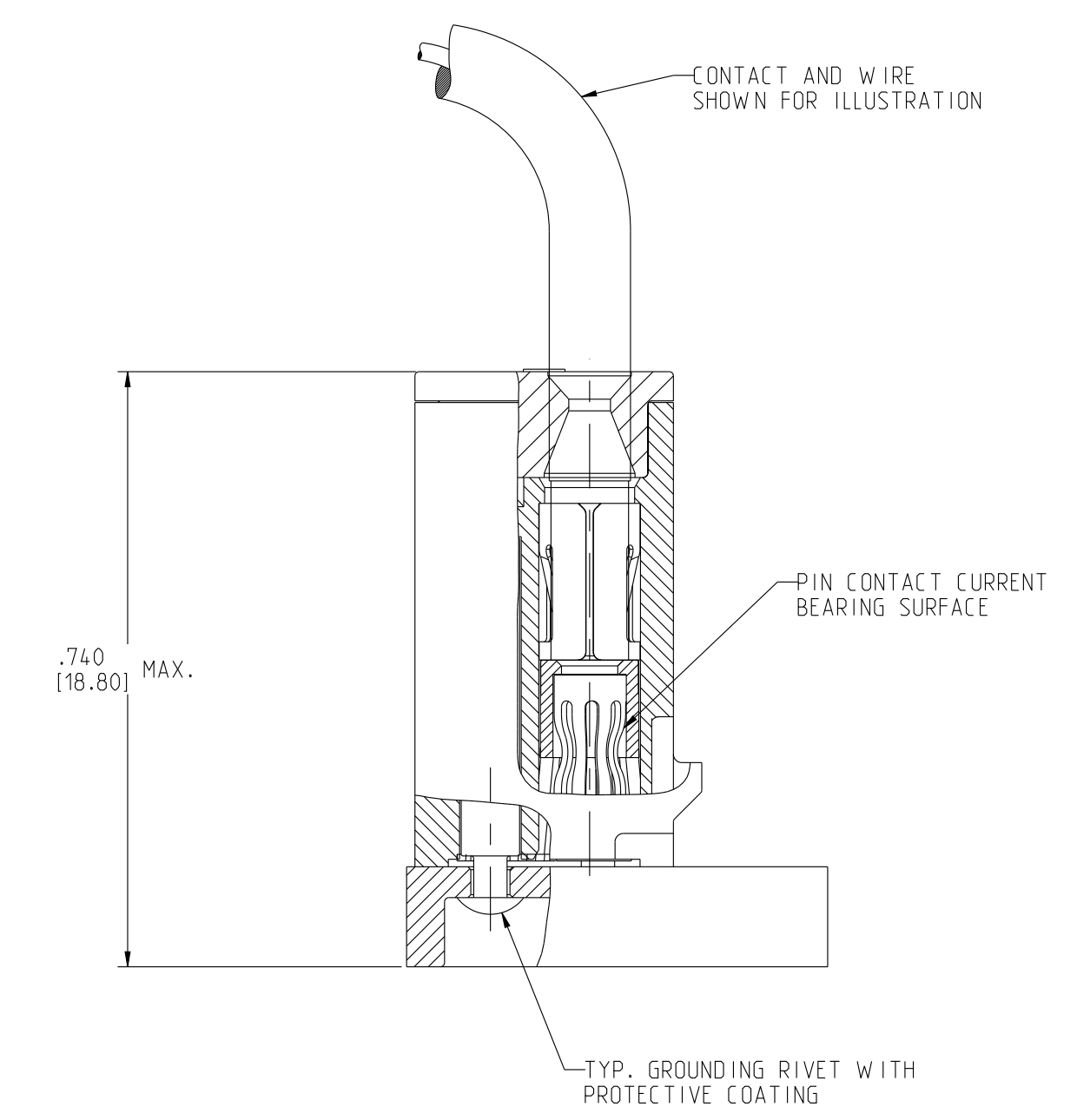

FULL VIEW
 SCALE 2:1

F	REVISED PER ECN 12046	RSK	SDH
E	REVISED PER ECN 7622	SDH	SDH
REV	DESCRIPTION	BY	CHKD
		DATE	DATE

DRAWING TITLE
GROUND BLOCK, RACK AND PANEL MOUNTING
 CAT. NO. **RBGP48-116 (SEE TABLE)**

CAGE NO: 09922 SIZE: D

CUSTOMER

SOURIAU

WWW.SOURIAU.COM

INTERPRET THIS DRAWING IN ACCORDANCE WITH ASME Y14.5M - 1994.

DRAWN: RSK 07-16-13
 CHKD: SDH 07-16-13
 DSGN: FDH 03-01-03
 MFG: DH 07-16-13
 QC: BB 07-16-13

DRAWING SCALE: 5:1

DRAWING NO. REV
 SE95203 F

1 OF 2

THIS DRAWING IS A CONTROLLED DOCUMENT FOR SOURIAU USA, INC. IT IS SUBJECT TO CHANGE WITHOUT NOTIFICATION. CONTACT THE DOCUMENT CONTROL CENTER FOR THE LATEST REVISION.
 THE INFORMATION CONTAINED IN THIS DRAWING IS CONFIDENTIAL AND MAY NOT BE DISCLOSED WITHOUT WRITTEN CONSENT FROM SOURIAU USA, INC.

PERFORMANCE CHARACTERISTICS

MECHANICAL:

MAGNETIC PERMEABILITY: ALL MATERIALS DO NOT EXHIBIT A RELATIVE MAGNETIC PERMEABILITY OF GREATER THAN 2 IN ACCORDANCE WITH MIL-STD-1344, METHOD 3006.

MAINTENANCE AGING: IN ACCORDANCE WITH MIL-STD-1344, METHOD 2002.

CONTACT INSERTION FORCES: 10 LBS [44.4N] MAX., IN ACCORDANCE WITH MIL-STD-1344, METHOD 2002.

CONTACT SEPARATION FORCES: 2.0 OZ [0.56N] MIN., IN ACCORDANCE WITH S280W601, PARA. 4.6.17.

CONTACT RETENTION: 20 LBS [88.9N] MIN., IN ACCORDANCE WITH MIL-STD-1344, METHOD 2007. AXIAL DISPLACEMENT DOES NOT EXCEED .012 [0.30].

PROBE DAMAGE: IN ACCORDANCE WITH S280W601, PARA. 4.6.12.

INTERNAL CONTACT DURABILITY: 100 CYCLES OF MATING AND UNMATING TO DEPTH OF MECHANICAL AND ELECTRICAL ENGAGEMENT IN ACCORDANCE WITH S280W601, PARA. 4.6.13.

OVERSIZE PIN CONTACT PROTECTION: GROUND BLOCK DESIGNED TO PREVENT ENTRANCE OF AN OVERSIZE TEST PIN OF Ø.077 [1.78] IN ACCORDANCE WITH S280W601, PARA. 4.6.15.

CONTACT WALKOUT: IN ACCORDANCE WITH S280W601, PARA. 4.6.16.

ENVIRONMENTAL:

SALT SPRAY: 48 HOURS IN ACCORDANCE WITH MIL-STD-1344, METHOD 1001, TEST CONDITION B.

VIBRATION (RANDOM): IN ACCORDANCE WITH MIL-STD-1344, METHOD 2005, TEST CONDITION V, LETTER E.

MECHANICAL (IMPACT) SHOCK: IN ACCORDANCE WITH MIL-STD-1344, METHOD 2004, TEST CONDITION A.

THERMAL SHOCK: IN ACCORDANCE WITH MIL-STD-1344, METHOD 1003, TEST CONDITION A, EXCEPT STEPS 2 AND 4 ARE 2 MINUTES MAX. DURATION. TEMPERATURE EXTREMES FOR STEPS 1 AND 3 ARE -65°C +0°/-5°C TO +125°C +5°/0°C [-85°F +0°/-9°F TO +257°F +9°/0°F].

TEMPERATURE LIFE: 125°C +5°/0°C [+257°F +9°/0°F] FOR 1000 HOURS IN ACCORDANCE WITH S280W601, PARA. 4.6.10.

ELECTRICAL:

CONTACT RESISTANCE: IN ACCORDANCE WITH MIL-STD-1344, METHOD 3004, SIZE 16-20: 45 MILLIVOLTS MAX., AT 7.5 AMPS WITH 20 AWG SILVER PLATED WIRE.

LOW LEVEL CONTACT RESISTANCE: IN ACCORDANCE WITH MIL-STD-1344, METHOD 3002, SIZE 16-20: .009 OHMS MAX., WITH 20 AWG SILVER PLATED WIRE.

VOLTAGE STABILITY: 4 MILLIVOLT MAX. DIFFERENCE BETWEEN RECORDED HIGHEST AND LOWEST POTENTIAL DROP VALUES IN ACCORDANCE WITH S280W601, PARA. 4.6.14.

NOTES: UNLESS OTHERWISE SPECIFIED

- GROUNDING BLOCK ACCOMMODATES PIN CONTACTS PER MIL-C-39029/1-101, WITH A WIRE RANGE OF 24-22-20 AWG. USE INSERTION/REMOVAL TOOL PER MIL-I-81969/14C-11.

MATERIAL:

STRAIN RELIEF GROMMET: SILICONE RUBBER, COLOR RED.

GROMMET BONDING: EPOXY

GROUNDING MODULE BODY: GLASS FORTIFIED THERMOPLASTIC UL94V-0, COLOR BLUE

GROUNDING PLATE: ALUMINUM ALLOY PER QQ-A-200

GROUNDING RIVETS: ALUMINUM ALLOY.

GROUNDING SOCKET CONTACTS: BERYLLIUM COPPER.

CONTACT RETENTION CLIPS: BERYLLIUM COPPER.

SOCKET CONTACT SLEEVES: THERMOPLASTIC, LIQUID CRYSTAL POLYMER.

PROTECTIVE COATING: POLYURETHANE, COLOR OPTIONAL.

FINISH:

GROUNDING PLATE: SEE TABLE.

GROUNDING SOCKET CONTACTS: 50 MICRO INCHES [1.27 MICRONS] MIN. NICKEL ALL OVER, PIN CONTACT CURRENT BEARING SURFACE OVER PLATED WITH 50 MICROINCHES [1.27 MICRONS] MIN. HARD GOLD.

ESTIMATED CONNECTOR WEIGHT: 40 GRAMS [1.41 OZ]

CATALOG NO. DESCRIPTION TABLE		
CATALOG NO.	CUSTOMER PART NO.	GROUNDING PLATE FINISH
RBGP48-116	---	CHROMATE CONVERSION COATED PER MIL-C-81706, CLASS 3, METHOD C, COLOR GOLD [REF: ALODINE 1200]
RBGP48-116N	S280W601-116	NICKEL PLATED PER MIL-C-26074, CLASS 3, GRADE B, (500 MICROINCHES [12.7 MICRONS] MIN.)

LINEAR MEASURE:		DRAWING TITLE GROUND BLOCK, RACK AND PANEL MOUNTING																													
THIRD ANGLE PROJECTION		CAT NO.: RBGP48-116 (SEE TABLE)																													
TOLERANCES UNLESS OTHERWISE SPECIFIED		CAGE NO: 09922	SIZE: D																												
NO. OF PLACES	INCH (mm)	<table border="1"> <tr> <td colspan="2">CUSTOMER</td> <td colspan="2">SOURIAU</td> </tr> <tr> <td>ONE PLACE</td> <td>±.1 [±3]</td> <td>DRAWN: RSK 07-16-13</td> <td>CHKD: SDH 07-16-13</td> </tr> <tr> <td>TWO PLACES</td> <td>±.02 [±0.51]</td> <td>DSGN: FDH 03-01-03</td> <td>MFG: DH 07-16-13</td> </tr> <tr> <td>THREE PLACES</td> <td>±.010 [±0.25]</td> <td>QC: BB 07-16-13</td> <td>DRAWING NO. REV</td> </tr> <tr> <td colspan="2">ANGLES ±1°</td> <td colspan="2">DRAWING SCALE: 4:1</td> </tr> <tr> <td colspan="2"></td> <td colspan="2">SE95203 F</td> </tr> <tr> <td colspan="2"></td> <td colspan="2">WWW.SOURIAU.COM</td> </tr> </table>		CUSTOMER		SOURIAU		ONE PLACE	±.1 [±3]	DRAWN: RSK 07-16-13	CHKD: SDH 07-16-13	TWO PLACES	±.02 [±0.51]	DSGN: FDH 03-01-03	MFG: DH 07-16-13	THREE PLACES	±.010 [±0.25]	QC: BB 07-16-13	DRAWING NO. REV	ANGLES ±1°		DRAWING SCALE: 4:1				SE95203 F				WWW.SOURIAU.COM	
CUSTOMER				SOURIAU																											
ONE PLACE	±.1 [±3]			DRAWN: RSK 07-16-13	CHKD: SDH 07-16-13																										
TWO PLACES	±.02 [±0.51]			DSGN: FDH 03-01-03	MFG: DH 07-16-13																										
THREE PLACES	±.010 [±0.25]	QC: BB 07-16-13	DRAWING NO. REV																												
ANGLES ±1°		DRAWING SCALE: 4:1																													
		SE95203 F																													
		WWW.SOURIAU.COM																													
INTERPRET THIS DRAWING IN ACCORDANCE WITH ASME Y14.5M - 1994.	2 OF 2		PRO-E																												

THIS DRAWING IS A CONTROLLED DOCUMENT FOR SOURIAU USA, INC. IT IS SUBJECT TO CHANGE WITHOUT NOTIFICATION. CONTACT THE DOCUMENT CONTROL CENTER FOR THE LATEST REVISION.

THE INFORMATION CONTAINED IN THIS DRAWING IS CONFIDENTIAL AND MAY NOT BE DISCLOSED WITHOUT WRITTEN CONSENT FROM SOURIAU USA, INC.