

Aug.1.2018 Copyright 2018 HIROSE ELECTRIC CO., LTD. All Rights Reserved.
 In case that the application demands a high level of reliability, such as automotive,
 please contact a company representative for further information.

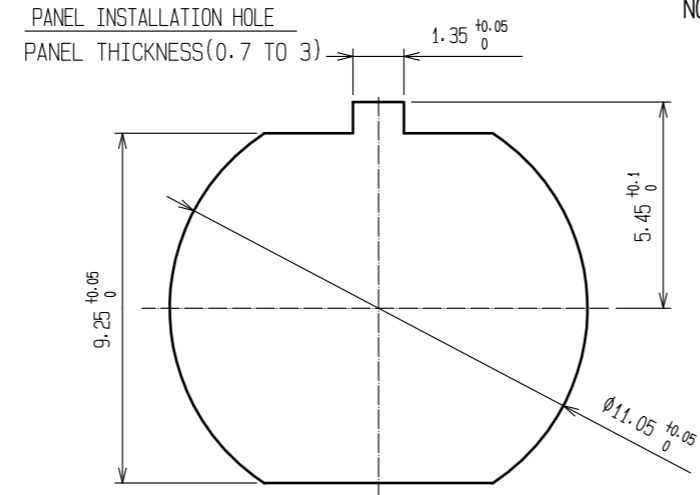
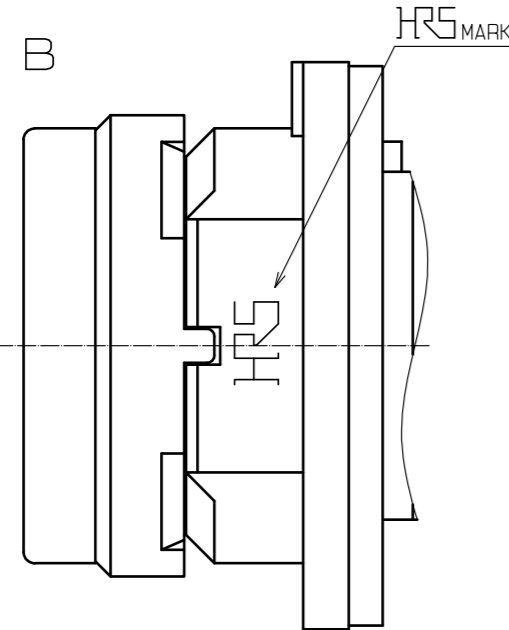
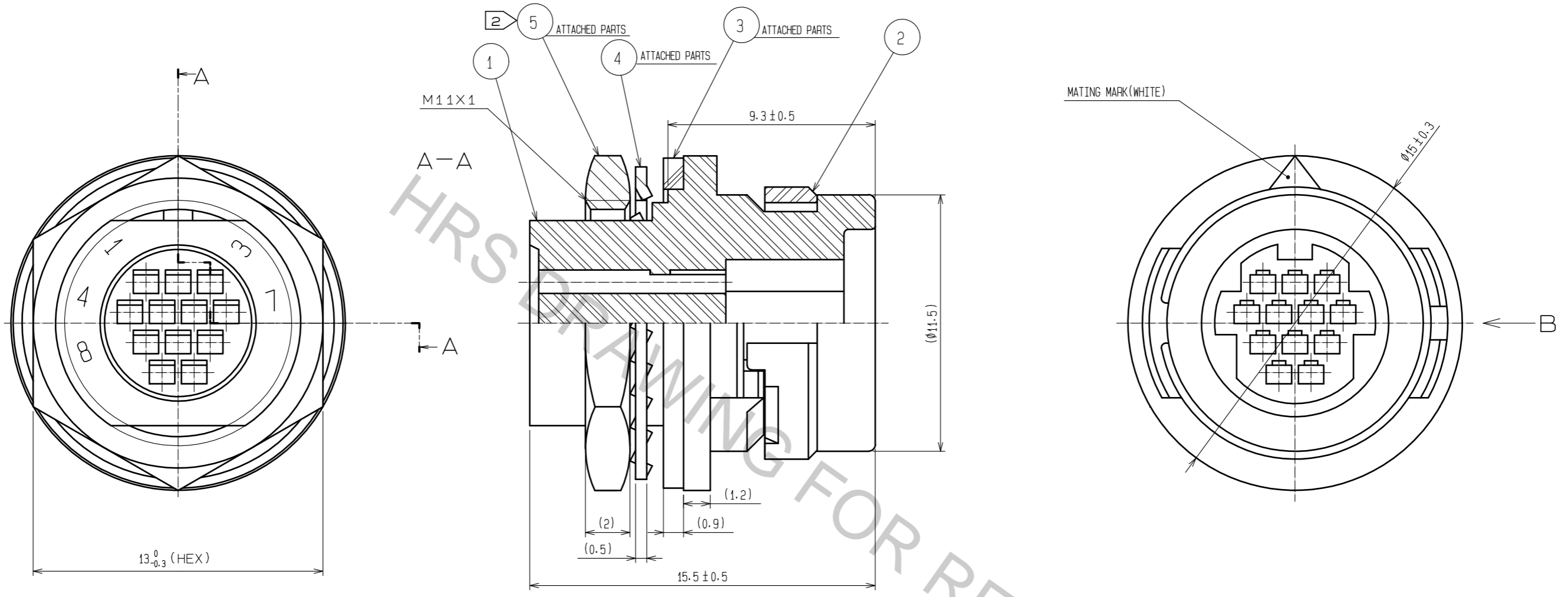

NOTES 1 APPLICABLE CRIMPING CONTACT:HR30-PC-211
 (APPLICABLE WIRE:26 TO 30 AWG WIRE JACKET DIAMETER:Ø1 MAX)
 APPLICABLE CONTACT WITHDRAWAL TOOL:HP30-TP
 ② THE RECOMMENDED CLUMP TORQUE OF REF. NO. ⑤ TO BE 0.8N·m.
 LOCTITE 263, LOCPRIMER 7649, LOCTITE JAPAN IS RECOMMENDED TO PREVENT REF. NO. ⑤ FROM LOOSENING.

NO.	MATERIAL	FINISH	REMARKS	NO.	MATERIAL	FINISH	REMARKS
3	CR	(BLACK)					
2	PPS	(BLACK)	UL94V-0	5	BRASS	NICKEL PLATING	
1	PPS	(BLACK)	UL94V-0	4	PHOSPHOR BRONZE	NICKEL PLATING	

UNITS	SCALE	COUNT	DESCRIPTION OF REVISIONS	DESIGNED	CHECKED	DATE
mm	5 : 1	△				
APPROVED : HY. KOBAYASHI			18.03.12	DRAWING NO. EDC-112155-31-00		
CHECKED : HY. KOBAYASHI			18.03.12	PART NO. HR30-7R-12PC(31)		
DESIGNED : DS. MATSUNE			18.03.12	CODE NO. CL130-1013-8-31		
DRAWN : DS. MATSUNE			18.03.12			