

THIS DRAWING IS UNPUBLISHED. RELEASED FOR PUBLICATION ,19 .
 © COPYRIGHT 19 BY AMP INCORPORATED. ALL RIGHTS RESERVED.

LOC		DIST		REVISIONS			
P	LTR	DESCRIPTION	DATE	DWN	APVD		
G	14	B	REVISED PER 0L20-0178-97	310CT97	DKS	CHK	

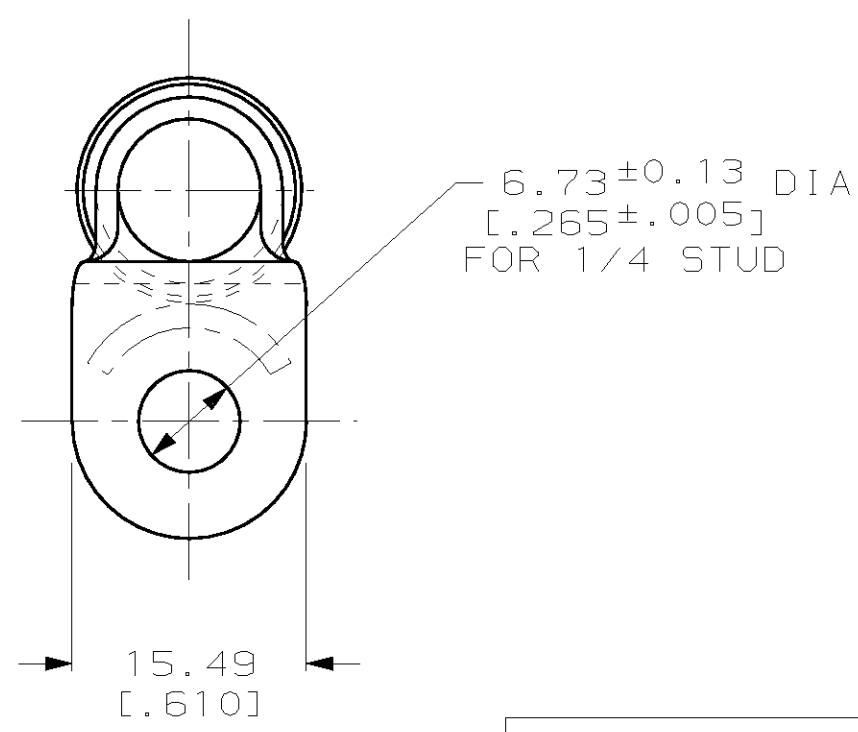
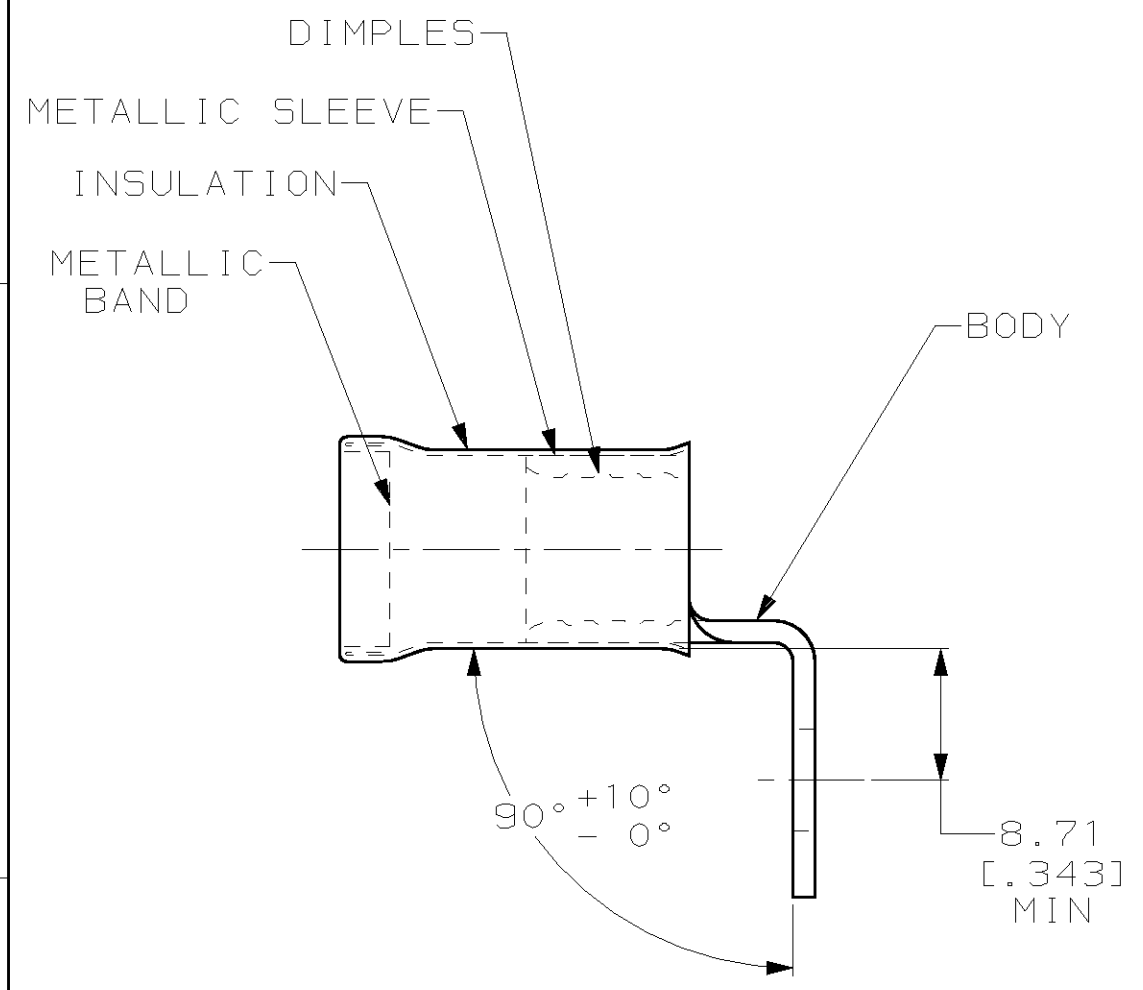

- 1 MATERIAL THK: 1.45 ± 0.08 [.057 ± .003]
- 2 WIRE INSULATION DIA: 12.83 [.505] MAX

<u>BODY:</u> COPPER PER ASTM B-152 TIN PL 0.00254 [.000100] MIN THK PER ASTM B-545 <u>INSULATION:</u> PVC <u>COLOR:</u> RED <u>METALLIC SLEEVE:</u> COPPER PER ASTM B-152 <u>METALLIC BAND:</u> STEEL PER ASTM A-109	52097
MATERIAL & FINISH	AMP PART NUMBER

AMP INCORPORATED
CUSTOMER SERVICE SYSTEMS

FOR ADDITIONAL PRODUCT INFORMATION OR COPIES OF DRAWINGS AND TECHNICAL DOCUMENTS	PRODUCT INFORMATION CENTER 1-800-522-6752	RECOMMENDED OPERATING TEMPERATURE: 105°C MAX
FOR APPLICATION TOOLING INFORMATION	TOOLING ASSISTANCE CENTER 1-800-722-1111	VOLTAGE RATING: NOT APPLICABLE
FOR ORDER ENTRY	1-800-526-5142	WIRE CROSS SECTIONAL AREA RANGE: 26.7-42.4mm ² [52,600-83,700] CIR MILS SOLID OR STRANDED

THIS DRAWING IS A CONTROLLED DOCUMENT.

DIMENSIONS:	TOLERANCES UNLESS OTHERWISE SPECIFIED:
mm [INCHES]	
	0 PLC ±-
	1 PLC ±-
	2 PLC ±0.20 [.008]
	3 PLC ±-
	4 PLC ±-
	ANGLES ±-
MATERIAL	FINISH
SEE TABLE	SEE TABLE

DWN DK SCHRUM 310CT97	AMP AMP Incorporated Harrisburg, PA 17105-3608
CHK MJ SPICER 03NOV97	
APVD JL MECKLEY 03NOV97	NAME TERMINAL, RING TONGUE, BENT 90°, AMPLI-BOND™, WIRE SIZE: 2 AWG
PRODUCT SPEC	SIZE CAGE CODE DRAWING NO RESTRICTED TO
APPLICATION SPEC	A3 00779 C- 52097 -
WEIGHT	CUSTOMER DRAWING SCALE 2:1 SHEET 1 OF 1 REV B